



# **NEW MEXICO**

# **WASTEWATER SYSTEMS**

# **OPERATOR CERTIFICATION**

# **STUDY MANUAL**

## **UTILITY OPERATORS CERTIFICATION PROGRAM**

Surface Water Quality Bureau  
New Mexico Environment Department  
PO Box 5469

Santa Fe, New Mexico USA 87502

**Tel.: (505) 827-2804**

**Fax.: (505) 827-0160**

**[www.nmenv.state.nm.us/swqb/fot](http://www.nmenv.state.nm.us/swqb/fot)**

**This page left intentionally blank.**

**New Mexico**

**Wastewater Systems**

**Operator Certification Study**

**Manual**

**Prepared By The**

**Water Utilities Technical Assistance Program**

**(NMSU DACC WUTAP)**

**For The**

**Utility Operators Certification Program**

**NMED Surface Water Quality Bureau**

**PO Box 5469**

**Santa Fe, NM 87502**

**November, 2007**

# INTRODUCTION

---

This wastewater study guide manual was produced by the NMSU DACC WUTAP (New Mexico State University, Doña Ana Community College, Water Utilities Technical Assistance Program) and funded by the NMED - SWQB, UOCP (New Mexico Environment Department - Surface Water Quality Bureau, Utility Operators Certification Program). Members of the WUTAP staff - Robert Gott, Program Coordinator; Robert George & Bernie Garcia, Field Training Specialists; and Nancy Gott, Office Manager - are solely responsible for the writing, editing, and compilation of this manual.

The intent of this manual is to provide a document that elaborates on the subject matter listed in the State Certification Need To Know Criteria. This manual will serve a dual purpose in that the operator will have the necessary information needed to study for their State Certification tests as well as an on hand reference manual that can be used to optimize their treatment processes.

This “WASTEWATER SYSTEMS OPERATOR CERTIFICATION STUDY MANUAL” has been created as a tool to assist Wastewater Systems operators in New Mexico in preparation for taking the New Mexico Collection Systems Operator, Small Wastewater Systems Operator, and Wastewater Systems Operator certification exams. There are two classes of Collection Systems Operator certification, two classes of Small Wastewater Systems Operator certification, and four classes of Wastewater System Operator certification. This guide is intended to be a complete reference manual for technical information. Its purpose is to guide the reader to study material for each of the major subject areas for each of the classes. There is no implied claim that this study manual covers every possible point on which an operator may be tested. However, it is intended to be comprehensive in its coverage of the essential information for each exam.

This study manual is divided into sixteen chapters.

Collection Systems exams will include information from Chapters 1 - 4, 8, 16

Small Wastewater Systems exam will include information from Chapters 1 - 9, 11, 15, 16

Advanced Small Wastewater Systems exam **will also** include information from Chapters 10, 12 - 13

Wastewater Systems Class 1 exam will include information from Chapters 1 - 9, 11, 15 -16

Wastewater System Class 2 exam will include information from Chapters 1 - 9, 11, 14 - 16

Wastewater Systems Class 3 and 4 exams will include information from **all sixteen** chapters.

The certification exams use several texts as reference manuals for exam topics. Each chapter of the study guide contains references to specific chapters of these manuals for those who wish to access more information on the topics covered in that particular section.

Office of Water Programs, California State University, Sacramento,

*Operation of Wastewater Treatment Plants*, Volume 1, 4<sup>th</sup> ed.

*Operation of Wastewater Treatment Plants*, Volume 2, 5<sup>th</sup> ed.

*Advanced Waste Treatment*, 4<sup>th</sup> ed.

*Operation and Maintenance of Collection Systems*, Volume 1, 5<sup>th</sup> ed.

*Operation and Maintenance of Collection Systems*, Volume 2, 5<sup>th</sup> ed.

Jenkins, Richard & Daigger, Manual on the Causes and Control of Activated Sludge Bulking and Foaming,

1<sup>st</sup>, 2<sup>nd</sup>, & 3<sup>rd</sup> eds.

Standard Methods for the Examination of Water and Wastewater, 18<sup>th</sup>, 19<sup>th</sup>, & 20<sup>th</sup> eds.

US EPA, NPDES Reporting Requirements Handbook

State and Federal Environmental Health & Safety Regulations

**Special thanks to:** NMED Utility Operators Certification Program for funding, Mike Coffman, Marie Ortiz, the NMED Point Source Regulation Section, and many others in the Surface Water Quality Bureau that assisted with review of specific chapters in the manual.

# NEW MEXICO ENVIRONMENT DEPARTMENT

## SURFACE WATER QUALITY BUREAU, UTILITY OPERATORS CERTIFICATION

---

The New Mexico Water Quality Control Commission, through the New Mexico Environment Department (NMED), grants certification for competency to the operators of water and wastewater systems. The Utility Operators Certification Program (UOCP) conducts the testing for certification. Certain requirements must be met before an operator is eligible to take a certification examination.

An operator begins the process by completing a test application from the Utility Operators Certification Program. Applications will only be accepted if they are submitted at least 30 days prior to the exam date. A certification officer will review each application to determine if the operator is eligible to take the requested examination. An application must be submitted every time a test is taken. Examinations are given several times a year at various locations around the state. A fee for each examination must be paid to **NMED Utility Operators Certification Program**. A check or money order for the proper amount as determined in the currently effective Fee Schedule must accompany each exam application.

Certificates must be renewed every three years. The renewal date will be the last day of the certificate holder's birthmonth following the third anniversary of the certificate. The UOCP also handles renewal of certificates. The fee for renewal is determined by an applicant's level of proficiency as listed in the currently effective Fee Schedule for **each** certificate.

The UOCP maintains training credits for certified operators only. Each operator must keep a record of all training credits earned. A record of current training credits is mailed to each certified operator yearly in July. Anyone who intends to apply for NM certification must include documentation of training credits when the application is submitted. Certified operators that are taking higher level exams may also have to submit training credit documentation to update training record files at the UOCP.

All correspondence, including applications, should be mailed to:

**NMED - Surface Water Quality Bureau  
Utility Operators Certification Program  
PO Box 5469  
Santa Fe, NM 87502**

Please feel free to call the Utility Operators Certification Program to request information on exam application forms, exam dates and locations, or certification and renewal. The telephone number for the office is **505-827-2804**. The web site is [www.nmenv.state.nm.us/swqb/fot/index.html](http://www.nmenv.state.nm.us/swqb/fot/index.html)

### IMPORTANT FACTS ABOUT OPERATOR CERTIFICATION

An operator, as defined by NM Water Quality Control Commission Regulations, is "any person employed by the owner as the person responsible for the operation of all or any portion of a water supply system or wastewater facility. Not included in this definition are such persons as directors of public works, city engineers, city managers, or other officials or persons whose duties do not include actual operation or direct supervision of water supply systems or wastewater facilities."

Under the Utility Operator Certification Act, "a certified operator is a person who is certified by the commission as being qualified to supervise or operate one of the classifications of water supply systems or wastewater facilities". Experience is "actual work experience, full or part-time, in the fields of public water supply or public wastewater treatment. Work experience in a related field may be accepted at the discretion of the commission". Any claim of related experience will be reviewed by the WQCC or its advisory body, the Utility Operators Certification Advisory Board.

The Advisory Board is an appointed "seven-member board from the certified water systems operators and wastewater facility operators to function with the commission to establish qualifications of operators, classify systems, adopt regulations and advise the administration of the Utility Operators Certification Act."

Experience that includes operation, maintenance or repair of water treatment and water distribution systems is accepted based on whether it is full or part-time. The Advisory Board will review and approve experience in other related fields, such as commercial plumbing or utility construction. Credit for part-time experience will be based on the percentage of time devoted to actual operation or maintenance. Full time water or wastewater laboratory experience may be counted as operator experience at a rate of 25% of actual experience. The credit for this experience will be determined by review of the Advisory Board.

## BASIC CERTIFICATION REQUIREMENTS

There are three basic requirements an operator must meet to qualify for New Mexico certification. All certified operators must have at least **one year** of actual experience in operation or maintenance of a public water system. All levels of certification require **high school graduation or GED** (see substitutions.) All levels of certification require a certain number of **training credits** in water systems O&M or related fields.

## SUBSTITUTIONS

One year of additional experience may be substituted for the high school graduation or GED requirement for all classes **except** Class 4. Education may be substituted for experience or training credits in some cases. The education must be in a water or wastewater related field. One year of vocational education can be substituted for up to one year of experience. Associate's and Bachelor's degrees in a related field may be substituted for up to three years of experience and 50 training credit hours, depending on the amount of actual experience. The criteria for substitution of education for experience are as follows:

No more than one year (30 semester hours) of successfully completed college education in a **non-related field** may be substituted for an additional **six months** of the required experience.

**One year** of approved vocational school in the water and/or wastewater field may be substituted for only **one additional year** of the required experience.

An **associate's degree** for a two-year program in an approved school in the water and/or wastewater field and **six months** of actual experience in that field (which may be accrued before, during, or after the school program) may be substituted for the requirements of any level up to and including **Class 2**. An **associate's degree** for a two-year program in an approved school in the water and/or wastewater field and **twelve months** of actual experience in that field (which may be accrued before, during, or after the school program) may be substituted for the requirements of any level up to and including **Class 3**.

Completion of at least **three years** of actual experience in the water and/or wastewater field plus **high school graduation** or equivalent, plus **15 semester hours** of successfully completed college education directly related to the water or wastewater field may be substituted for any level up to and including **Class 3**.

A **bachelor's degree** for a major directly related to the water or wastewater field plus **two years** of actual experience in that field may be substituted for any level up to and including **Class 3**.

BASIC CERTIFICATION REQUIREMENTS			
	Experience	Training Credits	Education
Class 1/ Small Systems	1 year*	10	HS Grad or GED*
Class 2	2 years*	30	HS Grad or GED*
Class 3	4 years*	50	HS Grad or GED*
Class 4	1 year as Class 3	80	HS Grad or GED
* - See Substitutions			



# TABLE OF CONTENTS

---

<b>CHAPTER 1: INTRODUCTION TO WASTEWATER CHARACTERISTICS AND TREATMENT</b>	
THE DEFINITION OF WASTEWATER	1-1
SOURCES OF WASTEWATER	1-1
TYPES OF WASTE DISCHARGES	1-1
Organic Wastes	1-1
Inorganic Wastes	1-1
EFFECTS OF DISCHARGING WASTES	1-1
Sludge and Scum	1-1
Organic Waste (in general)	1-2
Nutrients	1-2
Toxins	1-2
Suspended Solids	1-3
Pathogenic Organisms	1-3
Temperature Effects	1-3
pH	1-3
MEASURING THE STRENGTH OF WASTEWATER	1-3
MEASURING SOLIDS IN WASTEWATER	1-4
SOLIDS COMPOSITION IN TYPICAL DOMESTIC WASTEWATER	1-5
TYPICAL WASTEWATER TREATMENT PROCESSES	1-5
PRETREATMENT	1-5
Screening	1-5
Grit removal	1-5
Flow measurement	1-7
Lift pumping	1-7
PRIMARY TREATMENT	1-7
SECONDARY TREATMENT	1-7
DISINFECTION	1-7
EFFLUENT FLOW MEASUREMENT	1-7
SOLIDS HANDLING	1-7
Thickening	1-8
Digestion	1-8
Dewatering	1-8
Disposal or Re-use	1-8
OVERVIEW OF BASIC BIOLOGICAL PRINCIPALS RELATED TO WASTEWATER TREATMENT	1-8
NITROGEN COMPOUNDS IN WASTEWATER	1-9
<b>CHAPTER 2: OPERATOR SAFETY</b>	
SAFETY CONSIDERATIONS	2-1
OPERATOR SAFETY TRAINING PROGRAMS	2-1
EXCAVATION HAZARDS	2-1

Shoring	2-1
Shielding	2-2
Sloping (or benching)	2-2
Other Excavation Requirements	2-2
CONFINED SPACE HAZARDS	2-2
ELECTRICAL AND MECHANICAL HAZARDS	2-5
HAZARDOUS CHEMICALS	2-5
NOISE	2-5
PHYSICAL HAZARDS	2-6
INFECTIOUS MATERIALS	2-6
TRAFFIC HAZARDS	2-7
PERSONAL RESPONSIBILITY FOR SAFETY	2-7

### **CHAPTER 3: PLANT PRETREATMENT**

PURPOSE OF PLANT PRETREATMENT PROCESSES	3-1
SPECIAL SAFETY CONSIDERATIONS	3-1
BAR SCREENS	3-1
COMMINUTORS	3-1
GRIT REMOVAL FACILITIES	3-2
Long Channel Grit Chambers	3-2
Aerated Grit Chambers	3-2
FLOW MEASUREMENT	3-2
Formula for Calculating Flow	3-3
Common Devices Used for Open Channel Flow Measurement	3-3
Flumes	3-3
Weirs	3-4
Common Devices Used for Flow Measurement in Pumping Systems -	
Full Pipes	3-4
Flow Measurement Transmitters and Readout Equipment	3-4
General Units of Measurements	3-4

### **CHAPTER 4: WASTEWATER COLLECTION SYSTEMS**

DEFINITION OF WASTEWATER COLLECTION SYSTEMS	4-1
WASTEWATER COLLECTION SYSTEMS OPERATOR	4-1
WASTEWATER COLLECTION SYSTEM DESIGN	4-1
GRAVITY SEWER LAYOUT	4-1
Building Sewers	4-1
Lateral and Branch Sewers	4-1
Main Sewers	4-1
Trunk Sewers	4-1
Intercepting Sewer	4-1
CHARACTERISTICS OF GRAVITY SEWERS	4-1
Slope of Sewer	4-1



Design Flow	4-1
Velocity	4-2
Pipe Size	4-2
Location and Alignment	4-2
Depth	4-2
WASTEWATER COLLECTION SYSTEM CONSTRUCTION	4-2
PIPING AND JOINT MATERIALS	4-2
Asbestos Cement Pipe, (AC)	4-3
Cast and Ductile Iron, (CI and DI) Pipe	4-3
Reinforced or Non-reinforced Concrete, (RC and C) Pipe	4-3
Vitrified Clay, (VC) Pipe	4-3
Fiberglass Reinforced, (FR) Pipe	4-3
Acrylonitrile Butadiene Styrene, (ABS) Pipe	4-3
High Density Polyethylene, (HPDE) Pipe	4-3
Polyvinylchloride, (PVC) Pipe	4-4
PIPELINE INSTALLATION	4-4
EXCAVATION	4-4
Controlling Line and Grade	4-4
Pipe Bedding	4-4
Laying Pipe	4-5
Joining of Pipe	4-5
Trench Backfilling	4-5
Service Connections (Taps)	4-5
MANHOLES	4-6
GRAVITY SEWER MAINTENANCE	4-6
SEWER CLEANING METHODS	4-6
Hand Rodders	4-6
Power Rodders	4-10
High Velocity Hydraulic Cleaning Machines, (Jet Rodders)	4-10
PERFORMING CLEANING AND MAINTENANCE OPERATIONS	4-10
RECORDS	4-11
LIFT STATIONS	4-11
PURPOSE OF LIFT STATIONS	4-11
TYPES OF LIFT STATIONS	4-11
Dry Well Lift Stations	4-11
Wet Well Lift Stations	4-12
LIFT STATION COMPONENTS	4-14
Pumps	4-14
Wet Well	4-14
Hardware	4-14
Bar Racks	4-14
Dry Well	4-14

Valves	4-14
Electrical Systems	4-14
Alarms	4-14
Motor Control Center (MCC)	4-14
Hours Recorders	4-15
Pump Controls	4-15
Force Mains	4-16
TROUBLE SHOOTING LIFT STATION PROBLEMS	4-16
INFILTRATION AND INFLOW (I & I)	4-16
IDENTIFICATION OF I & I	4-16
CONTROL OF I & I	4-16
CROSS CONNECTION CONTROL	4-17
AS-BUILT PLANS	4-17

## **CHAPTER 5: WASTEWATER TREATMENT PONDS**

USE OF PONDS	5-1
HISTORY OF PONDS IN WASTE TREATMENT	5-1
POND CLASSIFICATIONS AND APPLICATIONS	5-3
SERIES OPERATION	5-3
PARALLEL OPERATION	5-3
POND CLASSIFICATION	5-3
Aerobic Ponds	5-3
Anaerobic Ponds	5-3
Facultative Ponds	5-3
Tertiary Ponds	5-4
EXPLANATION OF TREATMENT PROCESS	5-4
POND PERFORMANCE	5-5
STARTING THE POND	5-6
DAILY OPERATION AND MAINTENANCE	5-6
SCUM CONTROL	5-6
ODOR CONTROL	5-6
WEED AND INSECT CONTROL	5-7
Emergent Weeds	5-7
Suspended Vegetation	5-7
Dike Vegetation	5-7
LEVEE MAINTENANCE	5-8
HEADWORKS AND SCREENING	5-8
BATCH OPERATION	5-8
OPERATING STRATEGY	5-8
MAINTAIN CONSTANT WATER ELEVATIONS IN THE PONDS	5-8
DISTRIBUTE INFLOW EQUALLY TO PONDS	5-9
KEEP POND LEVEES OR DIKES IN GOOD CONDITION	5-9
OBSERVE AND TEST POND CONDITION	5-9

TROUBLESHOOTING	5-9
SURFACE AERATORS	5-9
SAMPLING AND ANALYSIS	5-12
FREQUENCY AND LOCATION OF LAB SAMPLES	5-12

## **CHAPTER 6: SEDIMENTATION**

PURPOSE OF SEDIMENTATION AND FLOTATION	6-1
CALCULATION OF CLARIFIER EFFICIENCY	6-3
TYPICAL CLARIFIER EFFICIENCIES	6-4
SLUDGE AND SCUM PUMPING	6-4
PRIMARY CLARIFIERS	6-5
Temperature	6-5
Short Circuits	6-5
Detention Time	6-5
Weir Overflow Rate	6-5
Surface Settling Rate or Surface Loading Rate	6-5
Solids Loading	6-5
TRICKLING FILTER CLARIFIERS	6-6
ACTIVATED SLUDGE CLARIFIERS	6-6
MAINTENANCE	6-6
SAFETY	6-7
COMBINED SEDIMENTATION-DIGESTION UNIT	6-7
PURPOSE OF UNIT	6-7
HOW THE UNIT WORKS	6-7
IMHOFF TANKS	6-7
PURPOSE OF THE UNIT	6-7
HOW IT WORKS	6-7
Settling Area	6-9
Digestion Area	6-9
OPERATIONAL SUGGESTIONS	6-9

## **CHAPTER 7: FIXED FILM SECONDARY TREATMENT**

TRICKLING FILTERS	7-1
DESCRIPTION OF A TRICKLING FILTER	7-1
PRINCIPLES OF TREATMENT PROCESS	7-2
PRINCIPALS OF OPERATION	7-3
CLASSIFICATION OF FILTERS	7-3
STANDARD-RATE FILTERS	7-3
HIGH-RATE FILTERS	7-4
ROUGHING FILTERS	7-4
FILTER STAGING	7-4
OPERATIONAL STRATEGY	7-4
RESPONSE TO ABNORMAL CONDITION	7-4

PONDING	7-5
ODORS	7-5
FILTER FLIES	7-5
SLOUGHING	7-5
POOR EFFLUENT QUALITY	7-5
COLD WEATHER PROBLEMS	7-5
MAINTENANCE	7-6
Bearings and seals	7-6
Distributor Arms	7-6
Underdrains	7-6
SAFETY	7-7
<b>ROTATING BIOLOGICAL CONTACTORS</b>	7-7
OBSERVING THE MEDIA	7-11
BLACK APPEARANCE	7-11
WHITE APPEARANCE	7-11
SLOUGHING	7-11
MAINTENANCE	7-11
<b>CHAPTER 8: MECHANICAL SYSTEMS</b>	
<b>CENTRIFUGAL PUMPS</b>	8-1
IMPELLER ROTATION AND CENTRIFUGAL FORCE	8-1
CENTRIFUGAL PUMPS	8-2
PROPELLER PUMPS	8-2
VERTICAL WET WELL PUMPS	8-2
<b>POSITIVE DISPLACEMENT PUMPS</b>	8-5
RECIPROCATING OR PISTON PUMPS	8-5
INCLINE SCREW PUMPS	8-5
PROGRESSIVE CAVITY PUMPS	8-6
<b>CENTRIFUGAL PUMP COMPONENTS</b>	8-7
ALIGNMENT	8-9
BEARINGS	8-10
LUBRICATION	8-10
<b>PUMP CHARACTERISTIC CURVES</b>	8-10
SHUT OFF HEAD	8-11
CHECKING SHUTOFF HEAD	8-11
<b>COMMON OPERATIONAL PROBLEMS</b>	8-11
CAVITATION	8-11
AIR LOCKING	8-12
LOSS OF PRIME	8-12
<b>ELECTRICITY</b>	8-12
ELECTRIC MOTORS	8-12
<b>PHASES</b>	8-12
Single Phase Motors	8-12
Three Phase Motors	8-12
Single Phasing	8-13
<b>CIRCUIT PROTECTION</b>	8-13

## **CHAPTER 9: DISINFECTION**

<b>CHLORINE TREATMENT TERMS</b>	<b>9-1</b>
CHLORINE DOSAGE	9-1
CHLORINE DEMAND	9-1
CHLORINE RESIDUAL	9-1
FREE CHLORINE RESIDUAL	9-2
COMBINED CHLORINE RESIDUAL	9-2
EFFECTS OF TEMPERATURE AND PH	9-2
BREAKPOINT CHLORINATION	9-2
<b>TESTING FOR CHLORINE RESIDUALS</b>	<b>9-3</b>
<b>CHLORINE GAS</b>	<b>9-3</b>
<b>CHLORINE POWDER</b>	<b>9-3</b>
<b>CHLORINE BLEACH</b>	<b>9-3</b>
<b>GENERAL CHLORINE SAFETY</b>	<b>9-3</b>
CHLORINATOR ROOM	9-3
CHLORINE STORAGE	9-4
CHLORINE CYLINDERS	9-4
HTH HANDLING SAFETY	9-4
RESPIRATORY PROTECTION	9-4
GAS MASKS	9-4
SELF-CONTAINED BREATHING APPARATUS (SCBA)	9-5
<b>CHLORINATION EQUIPMENT</b>	<b>9-5</b>
GAS CHLORINATION	9-5
EVAPORATORS	9-7
HYPOCHLORINATION SYSTEMS	9-7
<b>EMERGENCY RESPONSE PROCEDURES</b>	<b>9-8</b>
<b>DECHLORINATION</b>	<b>9-8</b>
PROPERTIES	9-8
CHEMICAL REACTION OF SULFUR DIOXIDE WITH WASTEWATER	9-9
<b>DISINFECTION USING MIXED-OXIDANT SYSTEMS</b>	<b>9-9</b>
SAFETY	9-9
<b>DISINFECTION USING ULTRAVIOLET (UV) SYSTEMS</b>	<b>9-9</b>
SAFETY	9-9
OPERATION	9-10

## **CHAPTER 10: ACTIVATED SLUDGE**

<b>PROCESS DESCRIPTION</b>	<b>10-1</b>
<b>OPERATION OF THE ACTIVATED SLUDGE PROCESS</b>	<b>10-1</b>
PROVIDING CONTROLLABLE INFLUENT FEEDING	10-1
MAINTAINING PROPER DISSOLVED OXYGEN AND MIXING LEVELS	10-2
CONTROLLING THE RAS PUMPING RATE	10-2
MAINTAINING THE PROPER MIXED LIQUOR CONCENTRATION	10-2
Review of Key Activated Sludge Operator Controls	10-3

<b>TYPES OF ACTIVATED SLUDGE TREATMENT PROCESSES</b>	10-3
CONVENTIONAL ACTIVATED SLUDGE	10-4
EXTENDED AERATION ACTIVATED SLUDGE	10-4
ACTIVATED SLUDGE PROCESS VARIANTS	10-4
<b>MECHANICAL COMPONENTS OF ACTIVATED SLUDGE SYSTEMS</b>	10-5
AERATION SYSTEMS	10-5
Surface Aerators	10-5
Diffused Aeration Systems	10-6
AERATION BLOWERS	10-6
Positive Displacement Blowers	10-6
Turbine Blowers	10-7
Air Flow Meter	10-7
Air Headers	10-8
Diffusers	10-9
Air Filters	10-9
SAFETY	10-9
SURFACE AERATOR SAFETY CONSIDERATIONS	10-10
MECHANICAL BLOWER SAFETY CONSIDERATIONS	10-10
AIR DISTRIBUTION SYSTEM SAFETY CONSIDERATIONS	10-10
<b>ACTIVATED SLUDGE PROCESS CONTROL</b>	10-11
INFLUENT CHARACTERISTICS	10-11
Organic and Hydraulic Loading	10-11
The Effect of Toxic Substances	10-11
AERATION BASIN ENVIRONMENT	10-11
Food and Dissolved Oxygen	10-11
Adequate Mixing	10-12
Maintaining the Correct F:M	10-12
Determining a Treatment Plant's F:M	10-12
SECONDARY CLARIFIER CONDITIONS	10-13
Clarifier Design Features	10-13
RAS Flow Control	10-13
Settleometer Test	10-14
<b>ACTIVATED SLUDGE PROCESS CONTROL STRATEGIES</b>	10-16
IMPORTANT OBSERVATIONS OF THE PROCESS	10-16
MLSS and MLVSS Concentration	10-17
Sludge Volume Index (SVI)	10-17
Mean Cell Residence Time (MCRT)	10-18
LIGHT MICROSCOPE	10-20
<b>ACTIVATED SLUDGE PROCESS PROBLEMS, TROUBLESHOOTING AND CORRECTIVE MEASURES</b>	10-24
Solids Separation Problems	10-24
RAS Chlorination	10-25
Foaming Problems	10-27

CHANGES IN INFLUENT FLOWS AND CHARACTERISTICS	10-28
Variable Hydraulic and Organic Loadings	10-28
Recycled Solids	10-28
Storm Events	10-29
Temperature Changes	10-29
Toxic Discharges	10-29
Changes in Sampling Program	10-29
RESPONDING TO PLANT CHANGES	10-30
<b>CHAPTER 11: SOLIDS HANDLING</b>	
<b>SOLIDS HANDLING PROCESSES</b>	11-1
DIGESTION	11-1
ANAEROBIC SLUDGE DIGESTION	11-1
How Anaerobic Digestion Works	11-1
Pipelines and Valves	11-3
Anaerobic Digester Tank	11-3
Sludge Feed (inlet) Line	11-3
Supernatant Tubes	11-3
Sludge Draw-Off Lines	11-3
Mixing System	11-3
Gas System	11-3
Digester Heating System	11-3
Floating Cover	11-3
Sampling Well	11-4
OPERATION OF ANAEROBIC DIGESTERS	11-4
TROUBLE SHOOTING ANAEROBIC DIGESTER PROBLEMS	11-4
AEROBIC SLUDGE DIGESTION	11-5
COMPONENTS OF AEROBIC DIGESTERS	11-5
Digester Tank	11-5
Aeration System	11-5
Sludge Inlet and Outlet Lines	11-5
Supernatant Tubes	11-5
OPERATION OF AEROBIC DIGESTERS	11-6
CHEMICAL SLUDGE STABILIZATION	11-6
SLUDGE THICKENING AND DEWATERING PROCESSES	11-6
GRAVITY THICKENERS	11-6
DISSOLVED AIR FLOATATION (DAF) THICKENERS	11-7
BELT FILTER PRESS	11-8
CENTRIFUGATION	11-9
SLUDGE DRYING BEDS	11-11
Sand Drying Beds	11-11
Asphalt Drying Beds	11-11
Vacuum Filter Beds	11-11



SLUDGE RE-USE AND DISPOSAL	11-12
LAND APPLICATION OF BIOSOLIDS	11-12
SURFACE DISPOSAL OF SLUDGE	11-13
LANDFILLING OF SLUDGE	11-13
<b>CHAPTER 12: TERTIARY TREATMENT</b>	
<b>CONSTRUCTED WETLANDS</b>	12-1
THEORY OF OPERATION	12-1
OVERLAND FLOW WETLANDS	12-1
EFFECTIVE USES OF CONSTRUCTED WETLANDS	12-1
WETLANDS OPERATIONS AND MAINTENANCE	12-2
PROCESS CONTROL TESTING	12-2
<b>PHOSPHORUS REMOVAL</b>	12-2
PHOSPHORUS AS A NUTRIENT	12-2
NEED FOR PHOSPHORUS REMOVAL	12-2
TYPES OF PHOSPHORUS REMOVAL SYSTEMS	12-2
LIME PRECIPITATION	12-2
How the Lime Precipitation Process Removes Phosphorus	12-3
Equipment Necessary for Lime Precipitation	12-3
LUXURY UPTAKE	12-3
Wastewater Treatment Units Used	12-4
Basic Principles of Operation	12-4
ALUMINUM SULFATE FLOCCULATION AND PRECIPITATION (SEDIMENTATION)	12-4
<b>CHAPTER 13: NITROGEN REMOVAL</b>	
THE NITROGEN CYCLE	13-1
THE NEED FOR NITROGEN REMOVAL	13-1
THE MANY FORMS OF NITROGEN	13-1
<b>BIOLOGICAL NUTRIENT REMOVAL</b>	13-2
NITROGEN FIXATION	13-2
ANAEROBIC DECOMPOSITION	13-2
NITRIFICATION	13-2
DENITRIFICATION	13-3
LAND APPLICATION OF EFFLUENT	13-3
<b>PHYSICAL NITROGEN REMOVAL</b>	13-3
AMMONIA STRIPPING	13-3
<b>CHEMICAL NITROGEN REMOVAL</b>	13-4
BREAKPOINT CHLORINATION	13-4
ION EXCHANGE	13-4
<b>OPERATIONAL CONTROL OF NITRIFICATION/ DENITRIFICATION</b>	13-5
NITRIFICATION	13-5
NITRIFICATION PROCESS MODES	13-5

Fixed Film Processes	13-5
Suspended Growth Processes	13-6
Nitrification Process Control	13-6
DENITRIFICATION	13-10
DENITRIFICATION PROCESS MODES	13-10
Fixed Film Processes	13-10
Suspended Growth Processes	13-10
DENITRIFICATION PROCESS CONTROL	13-11

## **CHAPTER 14: WASTEWATER LABORATORY**

PURPOSE OF THIS CHAPTER	14-1
IMPORTANCE OF THE LABORATORY	14-1
LABORATORY CERTIFICATION	14-1
LABORATORY SAFETY	14-1
<b>BASIC LABORATORY EQUIPMENT AND PROCEDURES</b>	14-1
WEIGHTS AND MEASURES	14-1
GLASSWARE	14-1
Beakers & Flasks	14-2
Graduated Cylinders	14-2
Volumetric Glassware	14-2
Pipettes	14-2
Burets	14-2
TEMPERATURE MEASUREMENTS	14-2
SOLUTIONS AND STANDARDS	14-2
<b>OVERVIEW OF INDIVIDUAL TESTS</b>	14-3
<b>BIOCHEMICAL OXYGEN DEMAND (BOD5)</b>	14-3
BOD Sample Collection and Preservation	14-3
Setting up the BOD	14-3
Incubating the BOD samples	14-4
Reading the BOD	14-4
Seed Corrections	14-4
Calculating BOD	14-4
BOD Quality Control	14-5
Dilution Water Blanks	14-5
Oxygen Depletion Rules	14-5
Sample pH adjustments	14-5
Dechlorination of Chlorinated Samples	14-5
Dissolved Oxygen Meter Calibration	14-5
Incubator Temperature Control	14-6
Glucose Glutamic Acid Standard (GGA)	14-6
Externally Supplied Standard	14-6
BOD benchsheet	14-6

FECAL COLIFORM MEMBRANE FILTER PROCEDURE	14-6
Fecal Coliform Sample Collection and Transport	14-6
Setting up the Fecal Coliform Membrane Procedure	14-8
Filtering Samples	14-8
Incubating Samples	14-8
Determining Fecal Coliform Densities	14-8
Fecal Coliform Reporting	14-8
Quality Control	14-9
Fecal Coliform Benchsheet	14-9
TOTAL SUSPENDED SOLIDS PROCEDURE	14-9
Total Suspended Solids Sample Collection and Preservation	14-11
Preparation of Glass Fiber Filters	14-11
Selection of Volume to be Filtered	14-11
Sample Filtration	14-11
Calculating TSS	14-11
TSS Quality Control	14-12
TSS Benchsheet	14-12
pH PROCEDURE	14-12
pH Sample Collection and Handling	14-12
pH Meter and Calibration Buffers	14-12
Calibration of pH meter	14-12
Measuring Sample pH	14-14
Quality Control For pH Measurements	14-14
TOTAL RESIDUAL CHLORINE PROCEDURE	14-14
TRC Sample Collection and Handling	14-15
TRC Equipment	14-15
Instrument Calibration	14-15
TRC Analysis	14-15
Quality Control - Sample Preparation	14-15
Quality Control - Standard Recovery	14-15
Quality Control- Performance Evaluation Standards	14-15

## **CHAPTER 15: SAMPLING AND REPORTING**

DISCHARGE MONITORING REPORTS (DMRS)	15-1
INSTRUCTIONS FOR COMPLETION	15-1
REVISED/CORRECTED DMRs	15-2
SELF-GENERATED DMR FORMS	15-2
NON-COMPLIANCE REPORTS (NCRs)	15-2
BYPASS/OVERFLOW/UPSET REPORTS	15-5
SCHEDULES/REPORTS	15-5
SLUDGE REPORTING REQUIREMENTS	15-5
FREQUENCY OF ANALYSIS/MONITORING PERIOD	15-6
Production & Use Forms	15-6

Land Application & Surface Disposal Forms	15-6
Additional Reporting Requirements	15-6
Completion of DMR Forms	15-6
Production & Use DMR (SLDP)	15-6
Land Application of DMR (SLLA)	15-7
SURFACE DISPOSAL DMR (SLSA)	15-9
LANDFILLING DMR (SLDF)	15-9
BIOMONITORING/TOXICITY	15-9
VALID TEST	15-9
DMRs	15-9
INVALID TEST	15-10
RETESTS	15-10
TRE	15-10
WET	15-10
MOST COMMONLY ASKED QUESTIONS	15-10

## **CHAPTER 16: STATE AND FEDERAL REGULATIONS**

ORIGIN OF ENVIRONMENTAL, SAFETY AND HEALTH REGULATIONS	16-1
FEDERAL CLEAN WATER ACT	16-1
NEW MEXICO ENVIRONMENTAL PROTECTION LEGISLATION	16-2
NMAC, TITLE 20, CHAPTER 6, PART 2	16-2
NMAC, TITLE 20, CHAPTER 6, PART 4	16-2
STANDARDS FOR THE USE OR DISPOSAL OF SEWAGE SLUDGE	16-3
OCCUPATIONAL SAFETY AND HEALTH ADMINISTRATION (OSHA) REGULATIONS	16-4

## **APPENDIX A: WASTEWATER MATH**

COMMON EQUIVALENTS USED TO SOLVE WASTEWATER MATH PROBLEMS	A-1
---	-----

## **APPENDIX B: WASTEWATER MATH**

FORMULAS USED TO SOLVE WASTEWATER MATH PROBLEMS	B-1
---	-----

## **APPENDIX C: FECAL COLIFORM**

HOW TO CALCULATE GEOMETRIC MEAN	C-1
---------------------------------	-----

## **APPENDIX D: DEFINITIONS AND CALCULATIONS FOR DMRs**

DEFINITIONS	D-1
EXAMPLE CALCULATIONS & REPORTING FOR CONCENTRATION, LOADING, FLOW, CL <sub>2</sub> RESIDUAL & pH	D-1
CALCULATING FECAL COLIFORM GEOMETRIC MEAN	D-4
USING THE MAL PROVISION TO DETERMINE REPORTABLE RESULTS	D-6

## **APPENDIX E: GLOSSARY OF WASTEWATER TERMS**

# CHAPTER 1: INTRODUCTION TO WASTEWATER CHARACTERISTICS & TREATMENT

---

## THE DEFINITION OF WASTEWATER

What is wastewater? We might understand this question better by first answering the question; what is *water*? Water is a compound made up of two parts hydrogen and one part oxygen. This is true, however, only for “pure” water. The water of our everyday lives contains many substances in addition to hydrogen and oxygen. These substances, since they are not found in “pure” water, may be considered impurities. In fact, the water that we drink every day contains many substances that can be considered impurities. Wastewater can be defined as a community’s spent water. Wastewater contains the impurities that were present when the water was obtained, and any impurities added through human uses. The term “sewage” is often used to refer to wastewater but is more properly applied to domestic (household) wastewater. Operators refer to the raw wastewater coming into a treatment plant as *influent*. The treated water discharged from a wastewater treatment plant is known as *effluent*.

## SOURCES OF WASTEWATER

Wastewater can originate from many sources such as; homes, businesses and industries. Storm water, surface water and ground water can enter the wastewater collection system and add to the volume of wastewater. The source of a wastewater will determine its characteristics and how it must be treated. For example, wastewater from homes and businesses (domestic wastewater) typically contains pollutants such as; fecal and vegetable matter, grease and scum, detergents, rags and sediment. On the other hand, wastewater from an industrial process (industrial wastewater) may include; toxic chemicals and metals, very strong organic wastes, radioactive wastes, large amounts of sediment, high temperature waste or acidic/caustic waste. Wastewater could even come from streets and parking lots during a rainstorm (storm wastewater) that could contain; motor oil, gasoline, pesticides, herbicides and sediment.

Most modern wastewater treatment facilities are designed to treat domestic wastewater. Industrial wastewaters that contain high strength waste, toxic waste or acid/caustic waste may have to be *pretreated* to make them safe to discharge to the collection system. If not, the processes at the wastewater treatment plant receiving the waste could be disrupted. Storm wastewater should be collected and treated (when necessary) separately from domestic and industrial wastewater.

## TYPES OF WASTE DISCHARGES

The purpose of treating wastewater is to prevent pollution problems in receiving waters. Pollution can be defined as the impairment of water quality to the degree that the water is no longer suitable for beneficial use (use as a drinking water source, fish habitat, irrigation, recreation, etc.). The degree and type of pollution is related to the type of waste discharged. Waste discharges can be placed into two broad categories: *organic* wastes and *inorganic* wastes.

**Organic Wastes** are those substances that *contain the element carbon* and are derived from something that was once living. Examples include: vegetable and fecal matter, grease, proteins, sugars and paper.

**Inorganic Wastes** are those substances that *do not contain carbon* and are not derived from something that was once living. Examples include: metals, minerals, salts, acids and bases.

## EFFECTS OF DISCHARGING WASTES

There are two routes by which pollutants enter receiving waters: **point sources**, such as a wastewater treatment plant discharges from an outfall pipe, and **non-point sources**, such as agricultural and industrial pollution that originates from a widespread discharge. In New Mexico, point source discharges can be made to streams, rivers and lakes or can be made to underground aquifers, because both surface and ground water discharges are common. Wastewater treatment plants, and wastewater treatment plant operators, control point source pollution. Non-point source discharges also occur to both surface and ground waters in New Mexico. Because non-point source pollution is not limited to a single outfall pipe, it is very hard to control.

The type of pollution, and the impairment of the receiving water are related to the type of waste being discharged. The following section discusses some common wastes and what effect they have upon receiving waters if not properly treated.

### **Sludge and Scum**

Sludge and scum are a component of domestic wastewater and some industrial wastewaters. They are primarily organic in nature. If not removed by the wastewater treatment plant, sludge and scum will accumulate on river bottoms and stream banks. Sludge deposits on river bottoms can prevent fish (particularly trout) from being able to spawn. Scum accumulated on stream banks can

cause odor problems, can harbor infectious diseases and is unsightly.

### Organic Waste (in general)

Organic waste, such as fecal and vegetable matter, toilet paper and sugars can cause a series of problems in receiving waters. One problem is *oxygen depletion*. Many aquatic organisms, including fish, need dissolved oxygen ( $O_2$ ) to survive. These types of organisms are referred to as **aerobes** and the environment they live in as **aerobic**. Much like you and I, aerobic bacteria breathe in  $O_2$  and produce carbon di-oxide ( $CO_2$ ) as a by-product. Natural surface waters typically contain enough dissolved oxygen to support aerobic organisms. *Oxygen depletion* can occur when aerobic bacteria use excess organic waste discharged into a receiving stream as food. As the aerobic bacteria multiply, they require more and more dissolved oxygen to sustain their growing numbers. When the population of aerobic bacteria grows large enough, they utilize more oxygen than is available in the river. After this happens, they (and most other aerobic organisms) in the river, die.



**Figure 1.1 - Oxygen Depletion**

Reprinted, with permission, from *Operation of Wastewater Treatment Plants*, Vol. I, 2<sup>nd</sup> ed., Office of Water Programs, California State University, Sacramento Foundation

When all of the dissolved oxygen in a river has been consumed, another type of organism begins to grow in the altered environment. **Anaerobic** bacteria live in conditions where there is no dissolved oxygen (septic). Anaerobic bacteria breathe by using the oxygen that is chemically combined with other elements, such as sulfate ( $SO_4$ ). When anaerobic bacteria use the oxygen from sulfate for respiration, hydrogen sulfide ( $H_2S$ ) gas is released as a byproduct. Hydrogen sulfide, sometimes called sewer gas, smells like “rotten eggs” and is very dangerous due to its explosive, toxic and suffocating characteristics. Oxygen depleted conditions lead to the growth of anaerobic bacteria, which results in odors in receiving waters. Furthermore, anaerobic bacteria release other objectionable by-products, such as organic acids, methane gas and nutrients, all of which can further harm the natural environment in the receiving stream. Because of the chain of events that the discharge of organic waste sets into motion, one of the principal goals of wastewater treatment is to prevent as much of it from getting into receiving waters as possible.

### Nutrients

Nutrients are substances that are required for the growth of living plants and animals. Some major nutrients are nitrogen and phosphorous. Both are found in wastewater in various forms. Nitrogen is typically present in influent in the forms of ammonia ( $NH_3$ ) and organically bound nitrogen. Both nitrogen compounds can be measured by the Total Kjeldahl Nitrogen (TKN) test. Nitrogen may be present in effluent as ammonia, organically bound nitrogen or even nitrite ( $NO_2$ ) and nitrate ( $NO_3$ ). Phosphorous is present in influent and effluent primarily in the form of phosphates ( $PO_4$ ). When large amounts of nutrients are allowed to enter into rivers and lakes, they can cause problems by increasing the growth of plants, such as algae. If the algae growth is extensive, it can choke up the water body. As the lower layers of algae are blocked off from the sun, they die and end up as food for bacteria. This begins the cycle described earlier under “organic waste discharges”, which leads to oxygen depletion.

### Toxins

Several substances in wastewater can be toxic if not properly treated. One of these is ammonia. Ammonia is usually the main form of nitrogen present in domestic wastewater, while industrial wastes may or may not contain ammonia. Most people that have owned a fish tank are aware that even small amounts of ammonia can kill aquarium fish. Similarly, large-scale fish kills can occur when effluent-containing ammonia is discharged into receiving waters. In the case of point source discharges, ammonia toxicity depends upon the pH and temperature as well as the dilution factor in the receiving water. Warm temperatures and high pH make ammonia much more toxic to fish. If the discharge is to a small stream where only a little dilution occurs, ammonia can cause serious problems.

Another toxin of concern is the residual chlorine that is left over from the disinfection process (this process is discussed further on in this text). If residual chlorine is discharged into a receiving water, even in small amounts, it can also be toxic to fish. For this reason, chlorinated effluents must often be **dechlorinated** to eliminate all of the measurable residual chlorine.

Last, with regard to toxins, is the problem of ground water contamination from nitrogen compounds such as nitrate (and ammonia that is converted into nitrate by soil bacteria). If nitrate contamination occurs in an aquifer that is used for drinking water, the nitrate could cause methemoglobinemia, also called *blue babies* syndrome, in infants that drink the water. Methemoglobinemia is a condition where the blood’s ability to carry oxygen is greatly reduced. Recent research has also linked long term consumption of high levels of nitrate to other health problems.



**Suspended Solids**

Inorganic suspended material like sand, dirt and silt and organic material like sludge both deposit on river bottoms and prevent fish from spawning. In New Mexico, one of the largest non-point source pollution problems is habitat loss caused by suspended solids silting up river bottoms. Point source discharges of sludge and sediment can cause the same problem.

**Pathogenic Organisms**

Wastewater can potentially contain any disease causing organism, or **pathogen**, that the people contributing waste to the collection system are infected with. Common diseases caused by water borne pathogens include; typhoid, hepatitis, cholera, dysentery and polio. Pathogens fall into the following categories:

<i>Pathogen Type</i>	<i>Examples</i>
Bacteria	Cholera, Shigella, Salmonella
Viruses	Norwalk, Rotavirus, Adenovirus
Protozoa	Giardia lamblia, Cryptosporidium parvum

**Table 1.1 - Types of Pathogens**

If pathogens are discharged without treatment into the natural environment, they will pose a danger to anyone that is exposed to them. For this reason, one of the primary goals of wastewater treatment is to **disinfect** the effluent before it is discharged. This can be accomplished by several different methods that rely upon very different principals. These are discussed later in Chapter 9 - Disinfection.



**Figure 1.2 - Waterborne Diseases**

Reprinted, with permission, from *Operation of Wastewater Treatment Plants*, Vol. I, 2<sup>nd</sup> ed., Office of Water Programs, California State University, Sacramento Foundation

Regardless of the method of disinfection, the test used to measure the *effectiveness* of disinfection is the same. Because so many varied types of pathogens could be present, it is not practical to perform laboratory test to detect each pathogen. Instead, we use a group of microorganisms that indicates that pathogens could be present.

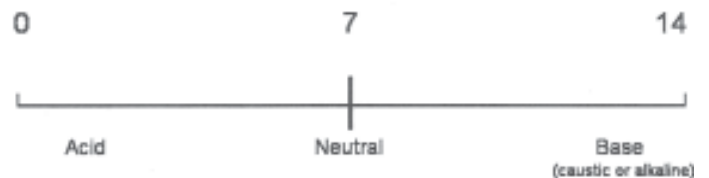
The group of microorganisms that we use to indicate the level of pathogenic contamination is the Fecal Coliform group. Fecal Coliform are a group of organisms that live in the intestinal tract of all warm blooded animals, including man. If Fecal Coliform are detected in water, it indicates that a warm-blooded animal has defecated into the water and therefore pathogens could be present. Although some members of the Fecal Coliform group are harmful to humans, such as toxin producing strains of Esterichia Coli (E. coli), they are not pathogens. As a whole, we all live quite comfortably as host to the billions, if not trillions, of Fecal Coliform in our intestines.

**Temperature Effects**

High temperature discharges can disrupt the natural ecology in surface waters by encouraging the growth of algae and aquatic plants that would not normally be as abundant. In addition, seasonal temperature changes can cause the treatment plant to operate less efficiently. This is most evident during cold weather because the growth and activity of the microorganisms in the treatment plant slows down considerably.

**pH**

pH is a measurement of water’s acid or alkaline condition. pH is measured on a scale that spans from 0 to 14 with 7 being the middle, or neutral value. pH values lower than 7 are progressively acidic while pH values that are higher than 7 are progressively basic, (also called caustic or alkaline). Most living organisms live in a narrow pH range that is near neutral. If an effluent has a pH that is higher or lower than that of the receiving water, the organisms in the receiving water may be killed off. In addition, if the pH of the influent coming into a wastewater treatment plant changes rapidly and significantly, the plant treatment processes may be disrupted.



**Figure 1.3 - The pH Scale**

**MEASURING THE STRENGTH OF WASTEWATER**

Because wastewater contains an unknown mixture of organic and inorganic pollutants, it is generally difficult to characterize. One test that is used to measure the overall strength of wastewater is the Biochemical Oxygen Demand (BOD) test. The BOD test measures the amount of oxygen that is consumed while a sample of wastewater is incubated



at a temperature of 20 °C. During the test, bacteria consume oxygen as they metabolize the organic material in the sample. Oxygen scavenging chemical compounds in the wastewater sample also consume oxygen, although this is typically only a small contribution to the overall oxygen demand. The more organic material and oxygen scavenging chemicals in a sample, the more oxygen will be consumed during the test. The more oxygen consumed, the higher the BOD. This test offers a particularly good way to measure the strength of wastewater because the test determines how much dissolved oxygen will be required to stabilize the waste, thus giving us an indication of what will be needed to treat an influent or what effect an effluent will have upon a receiving stream. (For more information on the BOD test, refer to Chapter 14, Laboratory Procedures).

### MEASURING SOLIDS IN WASTEWATER

We have discussed the different *types* of pollution and even discussed how we measure some of the different aspects of waste, such as BOD and Fecal Coliform. Now we will discuss how we measure solids and how we express their concentration. As we will see, the concentration of solids in typical domestic wastewater is actually quite small when compared to the amount of water present. Because of this, we express concentration in units that are practical to work with - milligrams per liter (mg/L). (See note.)

When we speak of solids in wastewater, we categorize them according to Table 1.2 opposite:

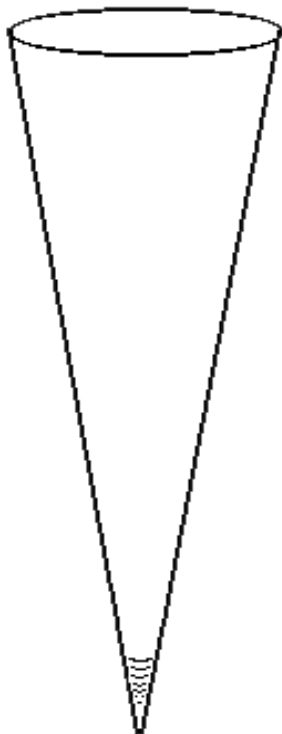


Figure 1.4 - Imhoff Cone

To actually measure the TS of a sample of wastewater we have to evaporate off the water in an oven and then weigh the residue. This residue represents everything (except gasses) that was in the sample, other than water. To determine the TDS we would do the same thing except that we would first filter the sample through a very fine mesh fiberglass filter and then perform the same test on the liquid that passed through the filter. To determine the TSS, we would dry and weigh the filter with the residue trapped on it and then subtract the weight of the filter. We might also want

**NOTE:**

One million milligrams is equal to one kilogram (2.2 lbs). One liter of pure water weighs one kilogram (at 60° F). Therefore, when you have one milligram of a solid in one liter of water the concentration is one part solid per million parts water (1 ppm). That is why we can use the units of mg/L and ppm interchangeably.

to measure the settleable portion of the TSS, known as Settleable Solids (SS). These are measured by settling a sample in a piece of laboratory glassware known as an *Imhoff Cone*. SS are reported as a volume (milliliters per liter; ml/L), not as a concentration (mg/L).

It is important to note that some of the TSS will not settle, even when given days or weeks. This non-settleable TSS is known as colloidal material. Colloids will not settle because they are very small and carry similar charges that keep them separated. The like charges on the colloids, which repel each other, overcome gravity's ability to settle them out.

SOLIDS GROUP	CONTENTS
Total Solids (TS)	Everything that is not water
Total Dissolved Solids (TDS)	All the solids that cannot be filtered out of the water
Total Suspended Solids (TSS)	All the solids that can be filtered out including: settleable solids and non-settleable solids (colloids)

Table 1.2 - Solids in Wastewater

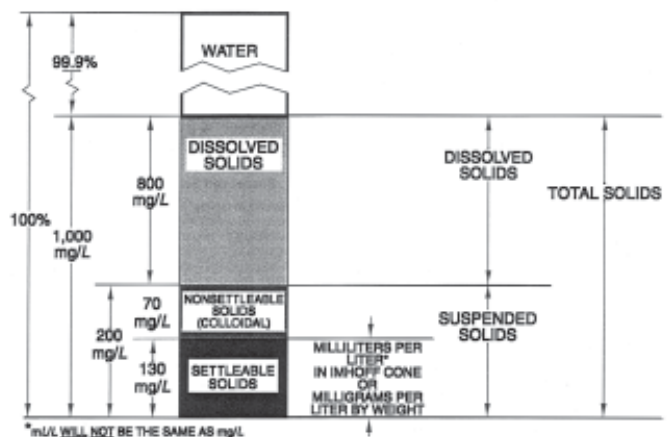


Figure 1.5 - Typical Solids in Domestic Raw Wastewater

**SOLIDS COMPOSITION IN  
TYPICAL DOMESTIC  
WASTEWATER**

If we could collect a sample of typical domestic wastewater the solids concentrations would be close to the levels shown in Figure 1.5.

As you can see, most of what makes up wastewater is water. In fact, 99.9% of typical domestic wastewater is water. The total solids represent only about 1/10<sup>th</sup> of one percent (0.1%), or 1000mg/L. You can also see that about 20%; (200mg/L) of the solids are made up by the TSS, of which 130mg/L are settleable and 70 mg/L are non-settleable. THE VAST MAJORITY, (80% OF THE SOLIDS), ARE DISSOLVED.

Some of the dissolved solids in domestic wastewater are organic and some are inorganic. The dissolved organic solids are often measured as dissolved, or *soluble*, BOD. The majority of this material was added to the wastewater through human use. Most of the dissolved inorganic solids were present when the water was obtained and treated for human consumption (before it became wastewater). The difference between the two types of dissolved solids is important because modern wastewater treatment plants are designed to remove almost all of the organic portion of the TDS but not the inorganic portion of the TDS, which usually passes right through the treatment plant. Generally, inorganic TDS does not cause pollution problems, although there are rivers in New Mexico that have limitations to the amount of overall TDS that can be discharged into them.

**TYPICAL WASTEWATER TREATMENT PROCESSES**

As we have already discussed, the processes used in a modern wastewater treatment plant are designed to remove most if not all suspended material, including settleable solids and colloidal particles. In addition, dissolved organic solids are removed to a high degree. Finally, pathogenic microorganisms are reduced to prevent the spread of water borne diseases. Separate units within the treatment plant accomplish the removal of different types of solids as well as pathogen reduction. Not all treatment plants employ the same units or treatment methods because there are many ways to accomplish the treatment goals. Location,

TYPICAL INFLUENT POLLUTANT CONCENTRATIONS		
PARAMETER	CONCENTRATION	EFFLUENT GOAL
BOD5	200 mg/L	< 30 mg/L
TSS	200 mg/L	< 30 mg/L
TDS	800 mg/L	< 1000 mg/L
Settleable Solids	10 ml/L	< 0.1 ml/L
pH	6 – 9	6 – 9
Fecal Coliform	Too Numerous to Count	< 500 cfu/ 100ml
TKN (Ammonia + Organic Nitrogen)	30 mg/L	< 10 mg/L Total Nitrogen
Nitrate/ Nitrite	< 1.0mg/L	
Phosphorous	2.0 mg/L	< 1.0 mg/L
Fats, Oils and Grease	Varies Greatly	None Visible

**Table 1.3 - Typical Influent Pollutant Concentrations**

economics and even historical precedent affect which types of treatment processes are employed.

Figure 1.6 - Treatment Plant Process Schematic, on the following page shows the common treatment processes and their location in the treatment train. Your treatment plant may differ considerably.

**PRETREATMENT**

Wastewater plant pretreatment processes are the first treatment to occur to the wastewater as it enters the plant. Pretreatment usually includes screening, grit removal, flow measurement and pumping.

**Screening** is accomplished by a barscreen which, as the name implies, is a screen made up of a number of bars arranged in such a way that the trapped material (screenings) can be easily removed. It is important that the screening material be removed so that it does not get caught up in mechanical equipment further on in the treatment plant. The importance of adequate screening for any size wastewater treatment facility CAN NOT be over-emphasized.

**Grit removal** can be accomplished in several ways. Grit refers to inorganic settleable solids, such as sand, rocks and eggshells. It is an important step in the treatment process because if not removed, grit will accumulate in pipes and tanks later on in the treatment plant. Grit can also cause excessive wear to lift pumps and valves. For this reason, grit removal should take place before the lift pumps whenever possible. The grit and screenings that are removed from the wastewater should be disposed of in

## *Treatment Plant Process Schematic*

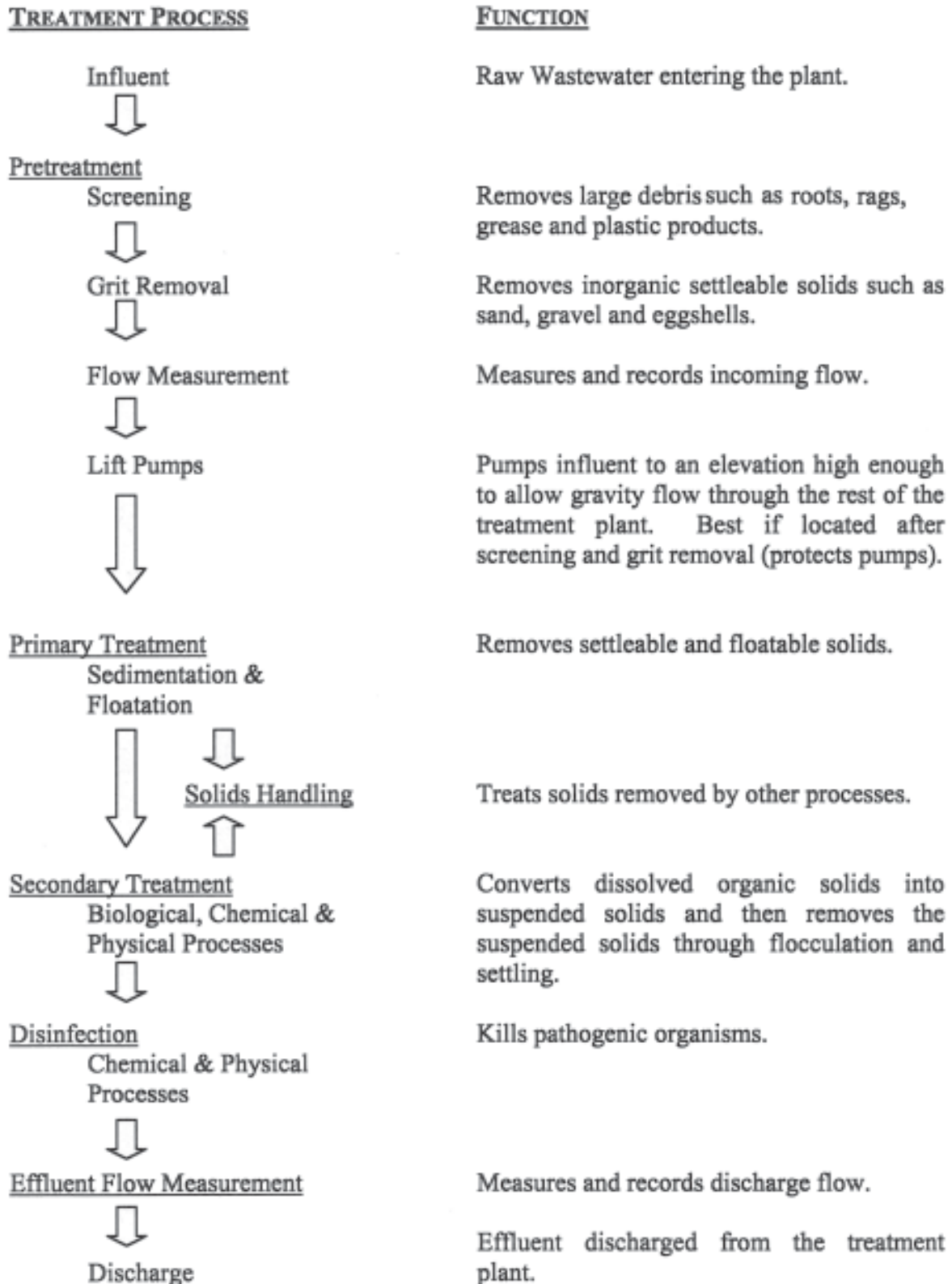


Figure 1.6 - Treatment Plant Process Schematic

an approved landfill after passing a paint filter test, which ensures no liquid is draining from them.

**Flow measurement** should be included on the influent side of all treatment plants but is most common in plants with a daily flow of 100,000 gallons or more. It is important to measure not only the daily flow but also the high and low flows so that the true maximum and minimum hydraulic loading is known. This information helps the operator understand what is happening in the treatment plant. Be aware that the flow does not come into most treatment plants at a constant rate. Instead, the flow arrives as peaks and lows that relate to the activity of the people contributing wastewater to the system. The largest peak is typically experienced during the morning hours (following the time when every body wakes up, showers, starts laundry etc). Smaller peaks usually occur after lunch and after dinner. At 3:00 AM there is generally very little flow entering the plant.

**Lift pumping** is necessary in many treatment plants although some plants receive their flow at a grade that eliminates the need for pumping. If possible, the design engineer should eliminate lift pumps whenever it is practical and cost effective. This is because pumps require significant maintenance and are prone to failure.

### **PRIMARY TREATMENT**

Primary treatment includes sedimentation and floatation. These processes are probably the oldest water treatment methods known to man. In a modern treatment plant, they are accomplished in a primary clarifier. A primary clarifier is a tank, (usually round), where the flow velocity of the wastewater is lowered to the point that suspended solids will settle out and floatable solids will rise to the surface where they can be skimmed off.

The advantage of primary clarification is that 30 – 50% of the influent BOD<sub>5</sub>, most of the suspended solids and much of the grease and floatable rubber and plastic product found in influent are removed. The main disadvantage is that the material that has been removed by a primary clarifier, (sludge and scum), must be continuously dealt with.

The sludge removed from primary clarifiers is *raw* and will create odor problems very rapidly unless stabilized (digested). The scum must also be removed and discarded or it will attract vectors (birds, mice, etc.) that could spread infection.

### **SECONDARY TREATMENT**

Secondary treatment involves physical, chemical and biological processes that convert the dissolved organic

component in the wastewater into settleable solids. Essentially, in secondary treatment we use the dissolved organic material in the influent as food for microorganisms. As the microorganisms consume the organic matter, they convert it into more microorganisms that are then separated from the water by gravity settling. This can be accomplished in many different types of secondary treatment systems such as; trickling filters, rotating biological contactors (RBCs), activated sludge and even lagoons. When using trickling filters, RBCs and activated sludge systems, the microorganisms are grown in one unit and the solids separation occurs in a secondary clarifier. In lagoon systems, the microorganisms grow and settle out all in the lagoon cells.

### **DISINFECTION**

After the effluent has been clarified, it is typically disinfected to lower the number of pathogenic microorganisms. This can be done in several ways including; chlorination, ozonation, ultra violet light exposure and even long detention times in lagoon cells. Chlorination is one of the most popular methods of disinfection. However, when chlorine is used to disinfect effluent that is discharged into surface water the effluent must often be de-chlorinated to prevent residual chlorine from harming organisms in the surface water body. This is most often accomplished by adding a sulfur compound that reacts with the chlorine to form inert salts.

### **EFFLUENT FLOW MEASUREMENT**

As discussed earlier, it is desirable to measure the influent flow so that the operator will know the plant hydraulic loading. Measurement of the effluent flow is not only desirable but is a requirement of almost any discharge permit. This is because the discharge volume must be known in order to allow the pollutant loading rates to the environment to be calculated. If you discharge one million gallons of effluent with a pollutant concentration of 10 mg/L, those one million gallons contain a total of 83.4 lbs. of the pollutant. The discharge volume (flow) must be known in order to make this calculation. Because the volume of influent and effluent can be very large, flow is usually expressed as millions of gallons per day (MGD) rather than gallons per day.

### **SOLIDS HANDLING**

If a wastewater treatment plant is performing properly a large portion of the suspended solids and dissolved organic solids will be removed from the water before it is discharged. These solids remain everyday while the treated water leaves the plant, consequently, they must be dealt with. This aspect of the treatment plant is separate from the wastewater treatment process and is know as solids handling. Solids handling generally involves four



components: thickening, digestion, dewatering and sludge disposal or re-use.

**Thickening** is performed to reduce the volume of sludge that must be stored in a digester. Thickening is accomplished by gravity thickeners, centrifuges, belt presses and diffused air floatation (DAF) units.

**Digestion** involves the breakdown of the solids by aerobic or anaerobic microorganisms. Digestion is done in aerobic (aerated) or anaerobic (heated, mixed, not aerated) digesters.

**Dewatering** is just as it sounds, removing water from the solids so they occupy less storage space. Dewatering can be accomplished in many ways including; gravity thickeners, drying beds, centrifuges, belt presses and diffused air floatation (DAF) units.

**Disposal or Re-use** of the solids after they have been digested and dewatered is the final step in the wastewater treatment process. If it is of a high quality and has undergone proper treatment, sludge generated from municipal wastewater treatment plants can be used beneficially as a resource to improve soil quality in various areas including; crop land, landscaping areas and land reclamation sites. If a beneficial use cannot be found, sludge may be disposed of in municipal landfills, surface disposal sites or, as a last resort, incinerated. Various state and federal regulations exist that pertain to sludge disposal and re-use.

**OVERVIEW OF BASIC BIOLOGICAL PRINCIPALS RELATED TO WASTEWATER TREATMENT**

Three main oxygen conditions exist that will sustain life and there are three classes of bacteria that survive in these oxygen conditions. Many of the processes in wastewater treatment involve manipulating oxygen conditions to grow certain types of bacteria or to make bacteria function in a specific way. The three oxygen conditions are as follows:

- **Aerobic** - Dissolved oxygen (O<sub>2</sub>) is available. Aerobic bacteria survive by breathing O<sub>2</sub>, producing carbon di-oxide (CO<sub>2</sub>) and water are the primary by-products.
- **Anaerobic** – No dissolved oxygen is available, but oxygen is present in the form of sulfate (SO<sub>4</sub>). Anaerobic bacteria can utilize the oxygen bound up in sulfate to breath. Hydrogen sulfide (H<sub>2</sub>S), carbon di-oxide and water are the main by-products.

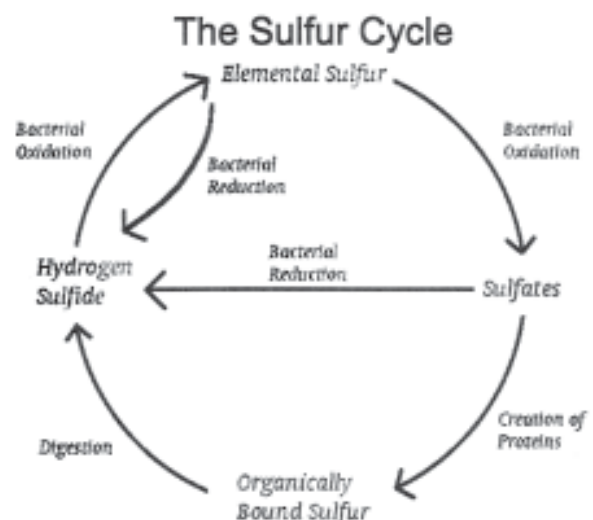
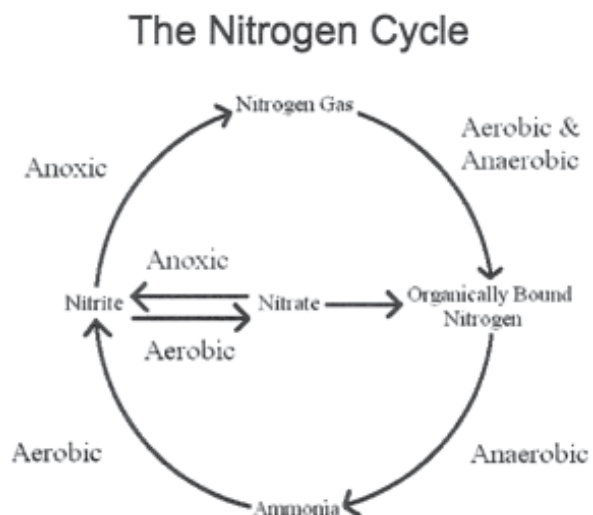
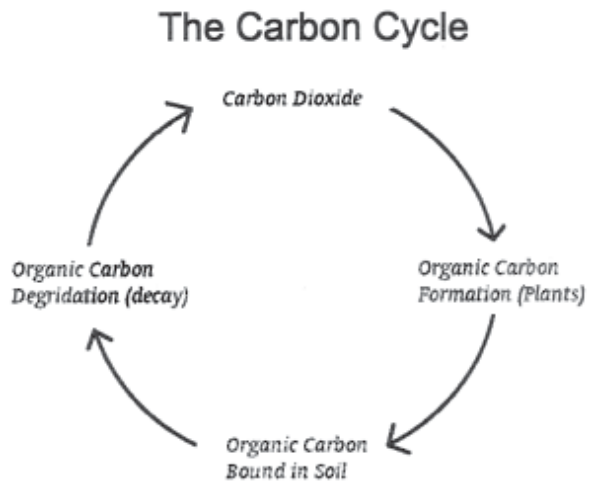


Figure 1.7 - Nutrient Cycles

- **Anoxic** - No dissolved oxygen is available, but oxygen is present in the form of nitrate ( $\text{NO}_3$ ). Facultative bacteria, which normally breath dissolved oxygen, can utilize the oxygen bound up in nitrate for breathing, releasing nitrogen gas ( $\text{N}_2$ ) as a by-product.

Elements are continually transformed into various compounds by living things as they are used for respiration, food and cell material. These transformations occur in cycles. The most important cycles to understand with regard to wastewater treatment are the carbon, nitrogen and sulfur cycles.

### **NITROGEN COMPOUNDS IN WASTEWATER**

- Total Kjeldahl Nitrogen (TKN)
  - TKN is the sum of the organically bound nitrogen and the ammonia
- Ammonia ( $\text{NH}_3$ )
  - Almost always present in raw domestic wastewater
- Nitrate ( $\text{NO}_3$ ) and Nitrite ( $\text{NO}_2$ )
  - Rarely present in raw domestic wastewater

### ***References***

Office of Water Programs, California State University, Sacramento, *Operation of Wastewater Treatment Plants*, Volume 1, 4<sup>th</sup> ed., Chapters 1, 2 and 3

## CHAPTER 2: OPERATOR SAFETY

Much of the information contained in this chapter is referred to separately throughout this study guide. This chapter is intended to focus special attention on this very important topic, however, it is not intended to serve as an all-inclusive guide to proper safety procedures.

### SAFETY CONSIDERATIONS

Safety should be of great interest to anyone working in the wastewater profession. On any given day at work operators could be exposed to the following hazards:

- Excavation hazards
- Confined spaces
- Electrical and mechanical hazards
- Hazardous chemicals
- Noise
- Physical hazards
- Infectious materials
- Traffic hazards

This is not a short list! Operators need to be aware of potential injury in all activities they perform at work. The best person to prevent an injury from occurring is YOU. Being aware of potential danger, planning ahead for safety measures, and developing safe work habits can prevent many injuries.

Most injuries involve sprains, slips, falls and being struck by objects. These are all injuries that can be avoided. The number of years of experience an operator has affects how likely they are to be injured. As experience increases, workers are more likely to understand the hazards and prevent injuries. This makes it very important that workers with more experience look out for entry-level employees, who are the most vulnerable. Insistence on following safety rules is the responsibility of every employee, but entry-level employees follow the lead of their supervisors. If inexperienced employees are taught bad habits by their supervisor, it is the supervisor, not the employee, who is to blame.

### OPERATOR SAFETY TRAINING PROGRAMS

On the job training (OJT) is a very valuable tool to not only upgrade operational skills, but also protect worker's health. There is a great need to improve the safety training at many wastewater treatment systems. The desire for a safe workplace must start at the top of the organization. Without this support, safety efforts will be un-funded and ineffective. Some aspects of a good operator-training program are:

1. Develop written Standard Operating Procedures (SOPs) for routine duties or equipment operation and have regular training sessions over each SOP. This will not only point out safety aspects of the

job, but will also be a way to train people in the most efficient way to work.

2. Have safety meetings for all workers at least once a month. Each supervisor should take turns presenting a meeting.
3. Form a safety committee to review accidents, inspect the facility for unsafe conditions, post warnings of suggest improvements to risky areas and enforce good work habits.
4. Have people learn CPR and First Aid skills. This can be done through the Red Cross, the American Heart Association, or maybe even your local fire department or ambulance service. These skills should be updated at least once every three years.

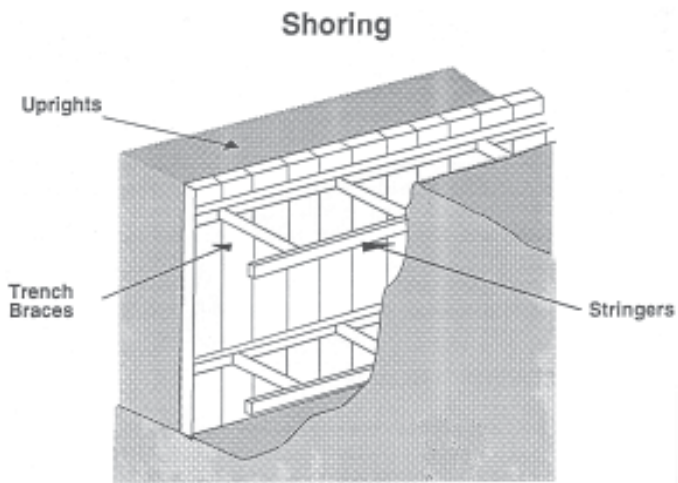
### EXCAVATION HAZARDS

Accidents at the site of trenching and other excavation activities are still all too common. Almost anyone working in the field for more than just a few years can remember witnessing or at least being told about a real life excavation accident where workers were injured or killed. It does not matter how long of a time you will spend in a trench, if there is no adequate cave-in protection, you could be buried below tons of dirt. THERE IS USUALLY NO WARNING AND NO TIME TO ESCAPE.

It is strongly recommended that some type of adequate cave-in protection be provided when the trench is four (4) feet deep or more. OSHA REQUIREMENTS STATE THAT ADEQUATE PROTECTION IS ABSOLUTELY REQUIRED IF THE EXCAVATION IS FIVE (5) FEET OR MORE IN DEPTH. Methods of adequate protection include shoring, shielding and sloping.

Shoring is a complete framework of wood and /or metal that is designed to support the walls of the trench. Sheeting is the solid material placed directly against the side of the trench. Either wood sheets or metal plates might be used. Uprights are used to support the sheeting. They are usually placed vertically along the face of the trench wall. Spacing between the uprights varies depending upon the stability of the soil. Stringers are placed horizontally along the uprights. Trench Braces are attached to the stringers and run across the excavation. The trench braces must be adequate to support the weight of the wall to prevent a cave-in. Examples of different types of trench braces include solid wood or steel, screw jacks, or hydraulic jacks.





**Figure 2.1 - Shoring**

Shielding is accomplished by using a two-sided, braced steel box that is open on the top, bottom and ends (trench box). This trench box is pulled through the excavation as the trench is dug out in the front and filled in behind. Operators must remain within the box to be protected. If the trench is left open behind or in front of the box, the temptation will exist to wander outside of the trench box's protection. Shielding does not actually prevent a cave-in the way shoring does because the space between the trench wall and the box are left open, allowing a cave-in to start. However, if a cave-in occurs, the workers inside the box will be protected from injury.

Sloping (or benching) is a practice that simply removes the trench wall itself. The angle of the slope required will depend on the stability and type of soil that the excavation site. An angle of 34 degrees (measured from the horizontal) is acceptable under all soil type and conditions. This requires a slope of 1 ½ ft across for every 1 ft vertical on both sides of the excavation. For example, a 5 ft deep trench would have to be sloped back 7.5 ft on each side under the least favorable soil stability conditions. For deep trenches, sloping will usually require more space than is available, so some other protective measure must be used (shoring or trench box).

Other Excavation Requirements

Certain soil conditions can increase the chances of a cave-in. These conditions include low cohesion, high moisture content, freezing conditions, or a recent excavation at the same site. Other factors to be considered are the depth of the trench, the soil weight, the weight of nearby equipment, and vibration from equipment or traffic. The spoil (dirt removed from the excavation) must be placed at least two feet back from the excavation and should be placed on one side of the trench only.

A ladder or other means of egress is required in the excavation if it is four or more feet deep. Ladders must be

placed so that there is one available every 25 feet and they must extend at least three feet above the excavation wall.

Before an excavation begins, OSHA standards require that the location of underground utility lines that may be encountered while digging be identified. In New Mexico, a free service known as New Mexico One Call is available for utility line location prior to excavation work. In Albuquerque, the phone number is 260-1990. For all other cities, towns, villages and outlying areas, call 1-800-321-2537. 48 hours notice is required, (not including weekends or holidays).

OSHA standards also require that a competent person inspect, on a daily basis, excavations and the adjacent areas for possible cave-ins, failures of protective systems and equipment, hazardous atmospheres, or other hazardous conditions.

**CONFINED SPACE HAZARDS**

A confined space is defined as a space that has any one of the following characteristics:

- Limited openings for entry and exit. This could mean a small opening, such as a manhole or could mean that a ladder, hoist or other device is needed to enter or exit a space.
- Unfavorable natural ventilation. Deadly gasses can accumulate or oxygen can be displaced.
- Not designed for continuous worker occupancy. Most confined spaces are entered for inspection, maintenance, repair, cleanup, or some similar task. They are not designed for routine entry or long-term occupancy.

ACCORDING TO OSHA STANDARDS, EACH ENTRY INTO A CONFINED SPACE REQUIRES A CONFINED SPACE ENTRY PERMIT. The confined space entry permit is "an authorization and approval in writing that specifies the location and type of work to be done, certifies that all existing hazards have been evaluated by the qualified person, and that necessary protective measures have been taken to ensure the safety of each worker". The permit is renewed any time the space is left and re-entered, even if for a break or lunch, or to go get a tool. The **qualified person** is a person designated in writing as capable (by education and/or specialized training) of anticipating, recognizing and evaluating employee exposure to hazardous substances or other unsafe conditions in a confined space. This person must be capable of specifying necessary control and/or protective action to ensure worker safety.

ACCORDING TO OSHA STANDARDS, ENTRY INTO A CONFINED SPACE IS NOT PERMITTED WITHOUT

# CONFINED SPACE ENTRY PERMIT

Date: \_\_\_\_\_

Time: \_\_\_\_\_

Location of Space or Vessel: \_\_\_\_\_

Purpose of Entering Space or Vessel: \_\_\_\_\_

## Persons Performing Work:

System Employees

\_\_\_\_\_  
\_\_\_\_\_  
\_\_\_\_\_  
\_\_\_\_\_

Non-System Employees

\_\_\_\_\_  
\_\_\_\_\_  
\_\_\_\_\_  
\_\_\_\_\_

<b>Precautions:</b>	Yes	No
Employee Qualified?	___	___
Safety Observer?	___	___
Space/Vessel Clean?	___	___
Space/Vessel's Atmosphere Safe for Entry?	___	___
Periodic/Continuous Monitoring Required?	___	___
Lines to Space Blanked or Disconnected?	___	___
Lock-out Devices?	___	___
Safety Lights?	___	___
Communication Devices?	___	___

<b>Protective Equipment:</b>	Yes	No
Belt/Harness/Lifeline?	___	___
Breathing Apparatus?	___	___
Warning Signs?	___	___
Protective Gear?	___	___
Fire Equipment?	___	___
Forced-Air Ventilation?	___	___
Rescue Gear on Hand?	___	___

**Misc. Equipment:** \_\_\_\_\_

\_\_\_\_\_  
\_\_\_\_\_  
\_\_\_\_\_  
\_\_\_\_\_  
\_\_\_\_\_

Name of Safety Observer:

\_\_\_\_\_

Misc. Precautions: \_\_\_\_\_

\_\_\_\_\_  
\_\_\_\_\_  
\_\_\_\_\_  
\_\_\_\_\_

Issued by:

\_\_\_\_\_  
**Supervisor or Supt.**

\_\_\_\_\_  
**Date**

Figure 2.2 - Confined Space Entry Permit

STAND-BY RESCUE EQUIPMENT AND A STAND-BY SAFETY PERSON. An approved safety harness is required so that an injured worker can be pulled out of the confined space. If the space is entered vertically, a hoist designed for lifting people is required. The job of the stand-by safety person is to remain on the outside of the space and be in constant contact (visual or speech) with the worker inside. The stand-by person should have no other duties but to observe the worker inside and to notify the appropriate people in case of emergency. Stand-by personnel should not enter a confined space until help arrives, and then only with proper protective equipment. Over 50% of confined space fatalities are attributable to rescue attempts by other workers. Rescuers must be trained and follow established emergency procedures. An unplanned rescue, such as when someone instinctively rushes in to help a downed co-worker, can easily result in a double fatality. **REMEMBER: AN UNPLANNED RESCUE WILL PROBABLY BE YOUR LAST.**

THE ATMOSPHERE OF A CONFINED SPACE MUST BE CHECKED PRIOR TO EVERY ENTRY. Three potentially dangerous atmospheric conditions can exist in confined spaces. These are:

1. Oxygen deprivation. Some gasses are heavier than air and so will fill up a confined space, which forces oxygen out. The oxygen concentration must not fall below 19.5% at any time.
2. Explosive conditions. Many gasses are explosive when present in certain ratios with oxygen. These ratios are defined by the upper explosive limit (UEL) and the lower explosive limit (LEL). The specific gravity of a gas indicates its weight as compared to air. Gasses such as hydrogen sulfide and chlorine collect at the bottom of confined spaces because they are heavier than air (high specific gravity). Gasses like methane collect on the top, because they are lighter than air (low specific gravity).
3. Toxic conditions. Some gasses are poisonous. A worker can be injured or killed by the poisonous effect.

The sense of smell is not a reliable check of the atmosphere within a confined space. Many gasses, such as hydrogen sulfide, rapidly paralyze the sense of smell. Other dangerous gasses have no smell at all. **THE ATMOSPHERE OF A CONFINED SPACE MUST BE**

**CHECKED WITH RELIABLE, CALIBRATED INSTRUMENTS PRIOR TO EVERY ENTRY.** Because gasses could exist at any area throughout the confined space, checks must be made of the TOP, MIDDLE AND BOTTOM. Detectors often rely on oxygen levels to determine explosive conditions, so testing of atmospheric hazards should always be done in the order of oxygen deficiency, explosive conditions and then toxic conditions. Always calibrate the detectors before opening the confined space. Atmospheric testing should continue while the

Some of the Common Dangerous Gases Found in Wastewater Treatment Plants and Collection Systems						
Name of Gas	Chemical Formula	Specific Gravity (Air=1.00)	Explosive Range (% in air)		Common Properties	Physical Effects
			LEL	UEL		
Methane	CH <sub>4</sub>	0.55	5.0%	15.0%	Colorless Tasteless Flammable Explosive	Asphyxiant Doesn't support life
Hydrogen Sulfide	H <sub>2</sub> S	1.19	4.3%	46.0%	Rotten-egg odor Colorless Flammable Explosive Poisonous	Death in a few minutes at 0.2% Paralyzes respiratory center. Odor not detectable at high levels
Carbon Dioxide	CO <sub>2</sub>	1.53	Not flammable		Colorless Tasteless Odorless	10% can't be endured for more than 10 min. Acts on nerves of respiration
Chlorine	Cl <sub>2</sub>	2.5	Not flammable Not explosive		Greenish-yellow Strong odor Highly corrosive	30 ppm coughing 40-60 ppm dangerous 1000 ppm fatal in a few breaths

**Table 2.1 - Dangerous Gasses in Wastewater Systems**

confined space is occupied. If any hazardous condition is detected, no entry into the confined space is permitted until the condition has been made safe.

**ENTRY INTO A CONFINED SPACE IS NEVER PERMITTED UNTIL THE SPACE HAS BEEN PROPERLY VENTILATED USING A SPECIALLY DESIGNED .** These blowers force all the air out of the confined space, replacing it with good air from outside. Forced air ventilation is a crucial practice that must continue as long as the space is occupied, even if no atmospheric hazard is detected. Atmospheric testing should never be performed instead of forced air ventilation, or vice versa. Because some of the gasses in confined spaces can be combustible, the forced air blowers used for ventilation must be specifically designed to be intrinsically safe. This means the blower itself will not create a spark and set off an explosion. Caution must be used to prevent the forced air blower intake from drawing in dangerous gasses, such as the exhaust from an idling work truck.



Finally, all equipment should be kept at least two feet from an overhead opening to a confined space (like a manhole or wetwell). Personal protective equipment (PPE), such as hardhats, coveralls, gloves and eye protection should be worn by all those inside. Only non-sparking tools and lamps should be used. Obviously, no one should be allowed to smoke anywhere near the entrance to a confined space.

### **ELECTRICAL AND MECHANICAL HAZARDS**

Wastewater treatment plant and collection system operations involve the use and maintenance of a variety of electrical and mechanical equipment. Injuries often result during maintenance activities due to equipment accidentally being started, pumps not being properly isolated and electrical supplies not being completely shut off. The OSHA mandated program known as **Lock-Out/Tag-Out** is designed to prevent these causes of injury. According to OSHA law, all equipment that could unexpectedly start-up or release stored energy must be locked out and tagged out to protect against accidental injury to personnel. Some of the most common forms of stored energy are electrical and hydraulic energy. Whenever it is necessary to work on a piece of equipment or machinery, the following procedure shall be adhered to:

1. Notify all affected employees that the system will be locked-out/tagged-out for maintenance. Ensure that the maintenance employee(s) understands the type and magnitude of the stored energy that the equipment utilizes.
2. If the equipment is operating, shut it down by the normal stopping procedures.
3. Operate the switch, valve, or other energy isolating devices so that the equipment is isolated from its energy source. Stored energy, such as that in springs, elevated machine members, rotating flywheels, water or sludge under pressure, air, gas and steam must be dissipated or restrained by methods such as repositioning, blocking, or bleeding down.
4. Lock-out devices shall be placed on electrical controls (circuit breakers) and on valves to prevent their operation. Each employee that is working on the equipment should have their own individually keyed lock on the lock-out devices and equipment controls should display prominent tags to warn other employees.
5. It is mandatory that the locked out valve or disconnect be tried to make sure that it cannot be opened or turned on. In addition, the machine controls themselves shall be tried to make certain the energy is "off". Return the operating controls to the neutral or off position after testing them.
6. The equipment is now locked-out and tagged-out and maintenance can begin.

7. After the maintenance work on the equipment is complete, all tools have been removed, equipment guards have been reinstalled, and employees are in the clear, remove all lock-out/tag-out devices. The equipment can now be restored to operation following normal procedures.

### **HAZARDOUS CHEMICALS**

Hazardous chemicals are used throughout wastewater treatment plants and in collection systems. Treatment plant laboratories use a variety of acids, bases and other potentially dangerous compounds. Operators could be exposed to various forms of chlorine, sulfur compounds, fuels and oils and even herbicides and insecticides. Employers are required to provide information to employees regarding the hazards associated with chemicals under OSHA's Hazard Communication Standard. These rules are designed to help minimize injuries caused by chemical over-exposure and misuse.

**A MATERIAL SAFETY DATA SHEET (MSDS) FOR EVERY HAZARDOUS CHEMICAL THAT IS USED OR PRODUCED IN A WASTEWATER TREATMENT SYSTEM MUST BE READILY AVAILABLE TO ALL OPERATORS.** The MSDS is a reliable reference (usually provided by the manufacturer) for the type of hazards the chemical presents and what to do in the event of an emergency. All operators should be familiar with the information on the MSDS through training provided by the employer and through personal study.

Safely handling the chemicals that are used at a treatment plant is the operator's responsibility. However, treatment plant managers should develop a coordinated response to an emergency situation, which includes local law enforcement and firefighters. If a situation develops that is beyond the emergency response plan's scope, Chemtrec will provide immediate advice for those at the scene of an emergency and then quickly alert experts whose products are involved for more detailed assistance and appropriate follow-up. **CHEMTREC CAN BE REACHED TOLL-FREE AT 1-800-424-9300.**

### **NOISE**

Noise is a hazard that is often overlooked. Prolonged exposure to high noise levels (85 decibels or higher) can lead to permanent hearing loss. Excessive noise can come from motors, blowers, pumps, chlorine ejectors, power tools, lawn mowers and irate supervisors. Noise levels throughout the plant should be periodically checked using a standard sound level meter. In general, if you have to

<b>Duration: Hours Per Day</b>	<b>Sound Level: dBA Slow Response</b>
8	90
6	92
4	95
3	97
2	100
1½	102
1	105
½	110
¼	115

**Table 2.2**  
*OSHA Mandated Noise Exposure Limits*

shout or cannot hear someone talking to you in a normal tone of voice, the noise level is excessive. Employer provided hearing protection, such as ear-plugs or muffs, are required if the noise source cannot be eliminated. Employees shall not be exposed to noise exceeding the duration/decibel levels shown in the following table.

**PHYSICAL HAZARDS**

Physical hazards include falls and slips from stairs, ladders, rough ground, or slick surfaces. Other physical hazards come from moving machinery, automatically operated equipment and obstructing pipes and walkways. Some of these are so-called built-in hazards because they are built in to the treatment plant. Built-in hazards should be modified, if possible, or clearly labeled and personnel made aware of their presence.

Other ways of avoiding injuries from physical hazards are to use the proper ladder or tool for the job, fill in holes, post barricades and put additional tread on steps. Emphasis should be put on good housekeeping as a way to eliminate accidents. Oil, water, polymer or other debris left in walkways causes many slips and falls. Cleaning up spills as they occur and using oil soak or oil soak booms can eliminate much of this. Placing trash barrels in all areas of the facility will help stop clutter. Most of all, enforcing good housekeeping habits among all workers is a must.

**INFECTIOUS MATERIALS**

Infections materials are present in wastewater. Wastewater can potentially carry hepatitis, polio, dysentery, typhoid, cholera, and a host of other disease caused by pathogenic protozoa, bacteria and viruses. Operators can become exposed to infectious materials throughout the treatment plant. Collection system operators are particularly at risk.

The OSHA Blood Borne Pathogen Standard is a law that is designed to limit worker’s exposure to two specific pathogens; Human Immune-deficiency Virus (HIV) and the virus responsible for Hepatitis B. The Blood Borne Pathogen Standard is mainly applicable to workers in the health profession that could have direct exposure to blood or other bodily fluids and syringes that are infected with these viruses. However, because blood and other bodily fluids, along with syringes and other sharps could be present in wastewater, the Blood Borne Pathogen Standard is applicable to many wastewater workers.

The Blood Borne Pathogen Standard requires employers to prepare a “written exposure control plan” and make it available to employees. The exposure control plan must contain the following elements, (at minimum), to meet the standard with regard to wastewater workers:

- An exposure determination must be made for each job classification that identifies task for which exposure could be expected.
- “Universal precautions” must be taken. This means that all blood and body fluids, and the surfaces they contact, are assumed to be infected at all times.
- Engineering and work practice controls must be implemented. If employee exposure can be eliminated or minimized by engineering controls or a change in procedures, they must be instituted.
- Training on disease transmission and symptoms must be provided to employees.
- Vaccinations for Hepatitis B shall be made available to all exposed employees at no-cost.
- Personal protective equipment, (i.e. rubber gloves, overalls, goggles), must be provided at no-cost to employees with the potential for exposure. This includes laundering of contaminated clothing and PPE.
- In the event of exposure, (like being cut while in a manhole or stuck with a needle while cleaning a barscreen), employers are required to provide no-cost medical evaluations to the exposed employee. This medical evaluation includes testing for HIV and Hepatitis B infection and follow-up medical assessments.

Studies have shown that the survival of the HIV virus in sewer systems is very low, but the Hepatitis B virus can persist for long periods. Some situations greatly increase the risk of exposure, such as working in a manhole that receives wastewater directly from a clinic or hospital. In these situations, a very high level of precaution needs to be taken (this starts with identifying the situation). However, adequate precautions must be taken in all situations where exposure to infectious agents is a possibility.

In addition to wearing the appropriate PPE, personal hygiene is one of the most effective precautions that wastewater workers can take. Examples of appropriate hygiene measures that should be taken by wastewater workers include:

- Wash hands and face with soap and warm water after finishing any task that involves potential exposure to infectious agents. For example, after cleaning a barscreen, entering a manhole, operating a rodding machine, hosing down an aeration basin or collecting laboratory samples.
- Wash hands with soap and warm water or hand sanitizer before smoking, eating or going home to your family.
- Leave work clothes at work, including work boots and launder them at work. If this is not possible, wash work clothes separately from household laundry and leave your work boots outside of your home.
- Cover all open wounds with bandages while at work.

Additionally, wastewater workers should maintain all of the immunizations and boosters recommended by their doctor. Immunizations and boosters are typically provided free of charge by county health services.

#### **TRAFFIC HAZARDS**

Understanding traffic safety and traffic control is essential for wastewater collection system operators, both to protect themselves and to protect the public. Some of the things that can be done to prevent injuries caused by traffic hazards include:

- Do not work during rush hour traffic if avoidable.
- Place warning signs or flagmen 500 feet ahead of the work zone.
- Always wear bright colored/reflective safety vests to make yourself and your co-workers highly visible.
- Place a barrier between the workers and traffic, such as a truck or an excavation spoils pile. The general rule is the bigger, the better.

#### **PERSONAL RESPONSIBILITY FOR SAFETY**

It is important to remember that we are each responsible for our own safety and for the safety of our co-workers. Don't treat safety issues as unimportant or boring. The life you save may be your own.

#### **References**

Office of Water Programs, California State University, Sacramento, *Operation of Wastewater Collections Systems*, Volume 1, 5<sup>th</sup> ed., Chapter 4, 7  
OSHA Confined Space Entry Standard  
OSHA Lock Out/ Tag Out Standard  
OSHA Hazard Communications Standard  
OSHA Personal Protective Equipment Standard  
OSHA Blood-borne Pathogen Standard

# CHAPTER 3: PLANT PRETREATMENT

## PURPOSE OF PLANT PRETREATMENT PROCESSES

Many types of debris will eventually end up coming into a wastewater treatment plant through the collection system. Roots, rocks, rubber and plastic products, bottles, rags, and even two-by-fours will find their way into the collection system and then to the treatment plant. In order to protect the plant equipment (pumps, valves, etc.) from damage, this debris must be removed early on. Grit (sand, silt, eggshells) will also arrive at the treatment plant. If grit is not removed early it will cause excess wear on lift pumps, plug lines and accumulate in primary and secondary treatment basins. The process units that remove this coarse debris are known as plant pretreatment processes.

## SPECIAL SAFETY CONSIDERATIONS

The area around plant pretreatment processes is often contaminated with grease, rags and other debris that is being removed from the wastewater. This makes the pretreatment process area frequently the site of injuries to operators due to slip and falls. Also remember that any disease that the people contributing to the sewer system may be infected with could potentially be in the raw wastewater. The tools used around pretreatment facilities (such as bar screen rakes) often become contaminated. Because of these facts, **ALL OPERATORS MUST OBSERVE GOOD PERSONAL HYGIENE AT ALL TIMES. ALWAYS WASH YOUR HANDS THOROUGHLY BEFORE EATING OR SMOKING.** Other good practices include removing work boots and clothing before entering your home and washing work clothes separately from the family laundry.

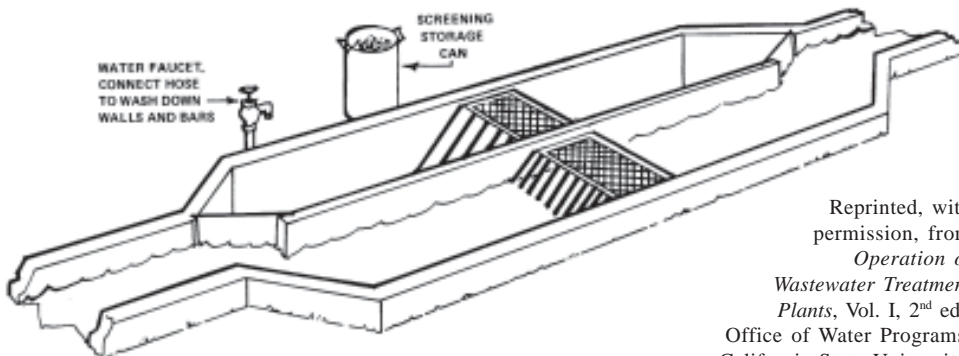
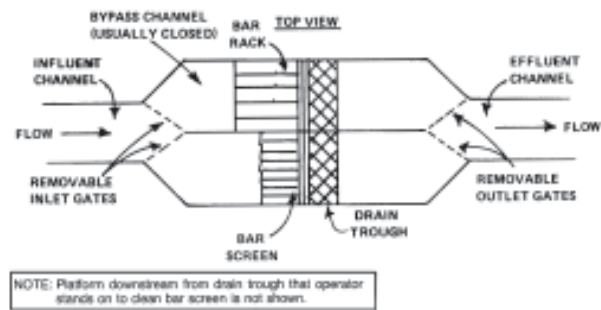


Figure 3.1 - Comminutor

## BAR SCREENS

When raw wastewater enters the treatment plant the first device that it usually encounters is a bar screen. A bar screen is constructed of a number of parallel slanted or vertical bars placed closely together in a channel so that wastewater can flow through the bars but rags and coarse debris will be trapped on them where it can be removed with a rake. The bars themselves must be made of a non-corrosive material such as stainless steel or aluminum. When the space between the bars is 3/8 to 2 inches the unit is called a bar *screen*. When the bars are spaced further than 2 inches apart it is called a bar *rack*. Bar racks are often found in by-pass channels where flows are diverted while the bar screen is being serviced or repaired. The system operator in a small treatment plant usually manually cleans the bar screen several times a day using a hand rake.

Larger facilities have mechanically cleaned bar screens that automatically rake the screenings based on a timer or some control mechanism. There are various types of mechanisms in use, the more common being traveling rakes that bring debris up and out of the channel and dispose of it in hoppers. These units need to be well lubricated and periodically adjusted. When performing maintenance lock-out power to the unit and divert the flow to another channel as a first step.

In either case, screenings should be allowed to drain back into the influent channel before they are placed in a container prior to final disposal. This container should be covered or enclosed to prevent flies, birds and mice from accessing the screened materials. Screenings are typically disposed of at a sanitary landfill after they pass a "paint filter test" that verifies no liquid is draining from them. Although common in the past, screenings should never be allowed to drain into the ground or buried for disposal.

## COMMUNITORS

Comminutors are devices that shred incoming rags and debris and leave them in the wastewater. They are generally installed in place of a bar screen. The advantage of this is that disposal of the screenings is eliminated. The disadvantage is that the shredded material often ends up fouling equipment further down stream and must be dealt with then. Additionally, unlike manual bar screens, comminutors require electrical power and can be maintenance intensive.

Reprinted, with permission, from *Operation of Wastewater Treatment Plants*, Vol. I, 2<sup>nd</sup> ed., Office of Water Programs, California State University, Sacramento Foundation



Recently some manufacturers have combined a comminutor and a fine mesh bar screen to provide very thorough removal of debris from influent wastewater. These improvements overcome most of the drawbacks associated with comminutors and bar screens alone.

### GRIT REMOVAL FACILITIES

Grit is composed of sand, sediment and eggshells (inorganic settleable solids). It must be removed early in the treatment process because grit will wear out the impellers of lift pumps and deposit in downstream tanks. If allowed to accumulate, a mixture of grit, grease and other cement like material will form a solid mass in pipes and in the bottoms of digesters. This material is notoriously difficult to remove so grit removal facilities should be designed to prevent grit from entering downstream treatment units.

The amount of grit that enters a treatment plant will vary depending on the size and age of the wastewater collection system. For every one million gallons entering a treatment plant, 1 – 4 cubic feet of grit should be removed daily. Grit is generally disposed of at sanitary landfills after passing a paint filter test. There are two major types of grit removal facilities; long channel grit chambers and aerated grit chambers.

#### Long Channel Grit Chambers

The simplest means of removing grit from wastewater is to pass the flow through long channels (20 – 40 ft) that allow the velocity to be reduced to around 1 ft/sec. The objective is to settle the grit on the bottom of the channel but keep the lighter settleable organic solids in suspension. When enough grit has accumulated in one channel, another one is placed on line and the full channel is dewatered and cleaned either by hand with shovels or with mechanical equipment such as a vacuum truck. Large installations have automatic grit rakes that remove grit from the chamber while it is still on-line.

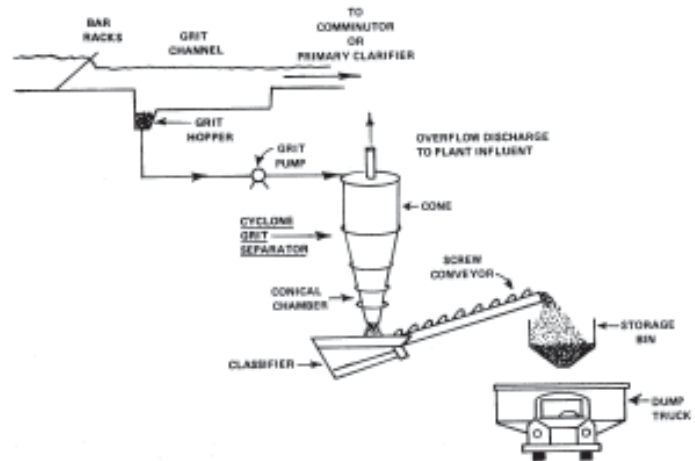
The velocity in the channel should be measured periodically to ensure it is near 1 ft/sec. This can be accomplished by placing a floating object, such as a stick or tennis ball, in the channel and recording the time it takes to travel a measured distance. At times of low flow the velocity may drop well below 1ft/sec. At peak flow the velocity may be higher. A device known as a proportional weir is often installed at the outlet to stabilize the velocity. Operators have used baffles fashioned from cinder blocks to improve grit channel characteristics. If the velocity is always too low, too much settleable organic material will be present in the grit and odors and other problems will result. If the velocity is too high, not enough grit will be removed. If the channel is long enough and a velocity near 1 ft/sec. is maintained most of the time, long channel grit chambers will do a good job of

removing grit and only a small amount of settleable organic material will be removed.

#### Aerated Grit Chambers

Aerated grit chambers remove grit in a very different way than long channel grit chambers. Aerated grit chambers are square or rectangular tanks that have air bubbled into one end. The mixture of air and water is less dense than water alone which causes the grit to rapidly settle to the bottom. Accumulated grit is removed from the bottom of the chamber by pumps or augers. The grit is then concentrated, usually by a cyclone separator, washed by a grit classifier to remove organic matter and finally dewatered and collected in a hopper for disposal. An added benefit of aerated grit chambers is the *freshening* of the incoming sewage that comes about from the aeration. Because of the ready supply of air, aerated grit chambers are most often found at activated sludge treatment plants.

The velocity of roller agitation regulates the size of particles of a given specific gravity that will be removed in the aerated grit chamber. If the velocity is too great, grit will be carried out of the chamber. If the velocity is too low, organic material will be removed with the grit. With proper adjustment of the quantity of air, almost 100% of the grit can be removed and washed as well.



**Figure 3.2 - Cyclone Grit Separator**

Reprinted, with permission, from  
*Operation of Wastewater Treatment Plants,*  
Vol. I, 2<sup>nd</sup> ed., Office of Water Programs,  
California State University, Sacramento  
Foundation



## FLOW MEASUREMENT

Although flow measurement devices do not actually treat wastewater, they are critical when it comes to properly operating treatment facilities and reporting discharge volumes for permit compliance purposes. Flow measurements are taken on the influent, effluent and recycle flows of large treatment plants and are taken on the effluent of small facilities, at a minimum. Without flow measurement, operators do not know the hydraulic and organic loading to their treatment plant or the effluent loading rates discharged to the receiving waters.

### Formula for Calculating Flow

There are two distinct situations where flow measurement occurs at wastewater treatment plants; in open channels with gravity flow and in pumping systems (full pipes). The methods used to measure flow in each situation can be very different but they all rely on one simple mathematical formula. The formula for flow is as follows:

$$Q = A \times V$$

Where;  $Q = \text{Quantity (flow)}$

$A = \text{Cross sectional area of channel or pipe}$

$V = \text{Velocity of liquid}$

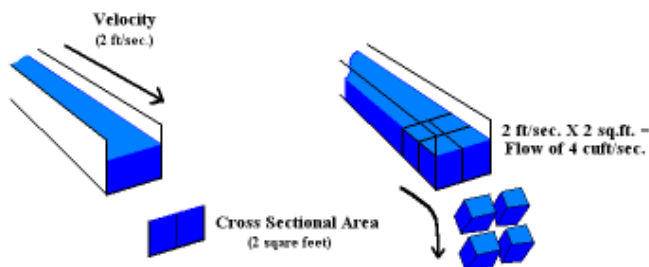


Figure 3.3 - Cross-Sectional Area of Pipe

What this formula tells us is that if we know the cross sectional area of the liquid and we know the velocity of the liquid we can calculate the flow. The cross sectional surface area is the area occupied by water if we were to cut a cross section through a pipe or open channel. The velocity can be measured using a stick, tennis ball or dye in the same way we would establish the velocity in a long channel grit chamber (see above). In this example a 2 ft wide-open channel is flowing with water at a depth of 1 ft. If the velocity of the water in the channel is 2 ft/sec, the flow is calculated to be 4 cuft/sec, using the formula  $Q = A \times V$ .

### Common Devices Used for Open Channel Flow Measurement

Open channel flow measurement is often used to measure the influent and effluent flow of wastewater treatment

plants. However, because of inaccuracy and other problems, open rectangular channels are seldom used as flow measuring devices themselves. *Flumes* and *weirs* are commonly used devices that refine the measurement of flow in open channels and make it more accurate.

### Flumes

A flume is a constriction within an open channel. Whenever a constriction occurs the level will rise within the channel. The more flow in the channel, the higher the water level will rise. If the flume is installed properly, no surging will occur and the water will be moving through in a plug flow fashion called laminar flow. Under these conditions, the velocity through the flume will be fixed. Because of this, we only need to measure the head rise at a specific point in the flume to determine the cross sectional area, (the width is fixed). With this information we can determine flow using the  $Q = A \times V$  formula, (but it is more convenient to use a graph that is prepared specifically for the size and type of flume that we are using). The most common type of flume used to measure flows in wastewater plants in New Mexico is the Parshall flume, (shown below). Parshall flumes are popular because they are inherently self-cleaning, they can handle wide flow variations, they are available in sizes ranging from one inch up to fifty feet in pre-constructed form and they require only a small head loss in measuring flow.

The head rise measurement in a Parshall flume is made two-thirds of the way up the approach channel. A fixed ruler is usually mounted at this point in the flume. This ruler is known as a staff gage and it reads out in tenths or hundredths of a foot, not in inches (see Figure 3.5). By reading the head rise off the staff gage and consulting a

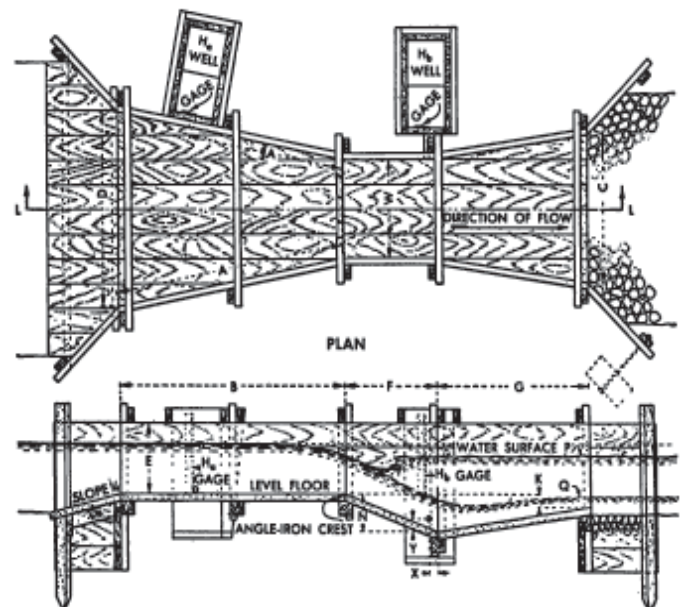
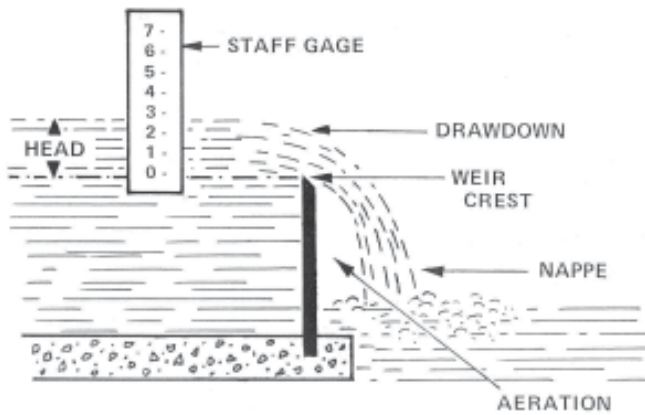


Figure 3.4

Plan & Elevation of the Parshall Flume



Sharp Crested Weir  
 The staff gage is located so that "0" on the gage is the same elevation as the weir crest.

**Figure 3.5 - Staff Gage**

chart for the particular size and type of flume being used, the flow can be determined. Other types of flumes that may be encountered in New Mexico include; "H-type" flumes and Palmer Bowlus flumes.

#### Weirs

Weirs are essentially dams that are placed across an open channel. Like flumes, weirs cause a head rise that can be translated into a flow measurement. There are many styles of weirs such as V-notch weirs (which come in many angles), rectangular weirs and trapezoidal weirs (shown below). Weirs should not be placed in flow streams that contain coarse debris or settleable solids because the debris will become caught on the weir and settleable solids will accumulate in the weir box in front of the weir. For this reason weirs are most often used to measure effluent flows where coarse debris and settleable solids should be at a minimum. To avoid false readings caused by the *drawdown* that occurs near the weir overflow, staff gages should be located at least four times the maximum head rise away from the weir.

#### Common Devices Used for Flow Measurement in Pumping Systems - Full Pipes

Flow measurement in wastewater pumping systems can be accomplished with several devices such as Venturi meters and magnetic flow meters. These devices measure the velocity of the liquid in the pipe. By knowing the pipe diameter and using the flow equation, ( $Q = A \times V$ ), flow can be calculated. In order for these devices to operate accurately, the pipe must constantly be full. The mechanical meters commonly found in potable water systems are generally not well suited to measuring wastewater flows, particularly when applied to influent or return sludge pumping. When used in wastewater applications these

meters tend to become plugged with biological growths or debris causing them to become inaccurate or stop functioning. Flow can also be established in wastewater pumping systems by emptying or filling a calculated tank volume. By measuring the time it takes to pump a known volume, (pumping 1000 gallons out of a wet well in 10 minutes for example;  $Q = 100\text{gpm}$ ), flow can be established. When a pump is equipped with an hour recorder and its pumping rate has been established with this method, totalized flows can be measured.

#### Flow Measurement Transmitters and Readout Equipment

Devices such as flumes, weirs and Venturi and magnetic meters are known as *primary flow measuring devices*. When installed and maintained properly they provide a flow measurement at the instant that they are read. If constant flow recording or totalized flow readings are desired, transmitting and readout equipment will be necessary. Transmitting devices include; ultra sonic, bubbler and probe type level detectors. Recording and totalizing instruments include; chart recorders, mechanical and electronic totalizers and computer programs designed to chart and totalize flow measurements.

#### General Units of Measurements

Two types of units are used in measuring liquid units of discharge and units of volume. Discharge or rate of flow is defined as the volume of liquid that passes a set point in a unit of time. Common discharge units used in the field of wastewater treatment are millions of gallons per day (MGD), gallons per minute (gpm) and cubic feet per second (cfs). Units of volume that are commonly used include millions of gallons (MG) and acre-feet (acft).

#### **References**

Office of Water Programs, California State University, Sacramento, *Operation of Wastewater Treatment Plants*, Volume 1, 4<sup>th</sup> ed., Chapters 3, 4

# CHAPTER 4: WASTEWATER COLLECTION SYSTEMS

---

## DEFINITION OF WASTEWATER COLLECTION SYSTEMS

Wastewater collection systems gather the used water from our homes, businesses and industries and convey it to a wastewater treatment plant. This type of system is also called a sanitary sewer. A similar system known as a storm water collection system conveys water resulting from runoff of rain and snow from buildings and paved and unpaved areas to a natural watercourse or body of water, usually without treatment. This type of system is also known as a storm sewer. In the past, some sanitary sewers and storm sewers were combined into one system. Unfortunately, during heavy rains the wastewater treatment plants served by combined sewers often became hydraulically overloaded and washed out into the receiving stream causing a complete treatment system failure. For this reason, combined sewers are now uncommon.

## WASTEWATER COLLECTION SYSTEMS OPERATORS

The ancient Romans were one of the first civilizations to employ wastewater collection through clay pipes and covered canal sewers. They understood all too well the importance of maintaining sanitary conditions. Modern wastewater collection systems are a sophisticated combination of components that include; gravity sewer lines, force mains, manholes, and lift stations. They represent one of the largest financial investments of public money for our municipalities. Why is it then that the personnel charged with operating and maintaining wastewater collection systems often feel as though they are the lowest paid employees in the entire city?

Because these systems are underground where the public does not see them they are all too often “out of sight, out of mind”. The general public rarely understands that operation and maintenance of wastewater collection systems is critical to maintaining the modern sanitary conditions we all take for granted. Only when the system fails, (such as during a sewer back-up), does the public take notice of the wastewater collection system. Wastewater collection system operators have a very dangerous, important job and are deserving of respect for their skill and dedication.

## WASTEWATER COLLECTION SYSTEM DESIGN

### GRAVITY SEWER LAYOUT

The largest component of a wastewater collection system is usually the gravity sewer. Gravity sewers follow the topography of the surrounding area, (lay of the land), to take advantage of the natural slope. They are designed to provide a flow velocity between 2 and 8 feet per second (fps), with 2.5 fps being ideal. If the velocity is too low, settleable solids will deposit in the sewer lines, if the

velocity is too high, erosion and damage of the collection system will occur. Gravity sewers are divided into the following sections:

### Building Sewers

A building sewer connects a building’s internal plumbing to the public wastewater collection system. The building sewer may begin at the **stub-out**, the property line or some distance (such as 2 to 10 ft.) from the building’s foundation. Where the building sewer ends marks the end of the building owner’s responsibility for maintenance and repairs. Beyond the building sewer, the wastewater collection system operators are responsible for maintenance, cleaning and repairs. This division should be clearly spelled out in local sewer ordinances.

### Lateral and Branch Sewers

Lateral and branch sewers are the upper ends of the wastewater collection system. Sometimes they are located in **easements**, although this should be avoided where possible due to problems of access and limited work space.

### Main Sewers

Main sewers collect the flow from numerous lateral and branch sewers and convey it to larger trunk sewers.

### Trunk Sewers

Trunk sewers are the main “arteries” of the wastewater collection system and convey the wastewater from numerous sewer mains to a wastewater treatment plant or to an interceptor sewer.

### Intercepting Sewer

Sewer interceptors receive the wastewater from trunk sewers and convey it to the wastewater treatment plant.

## CHARACTERISTICS OF GRAVITY SEWERS

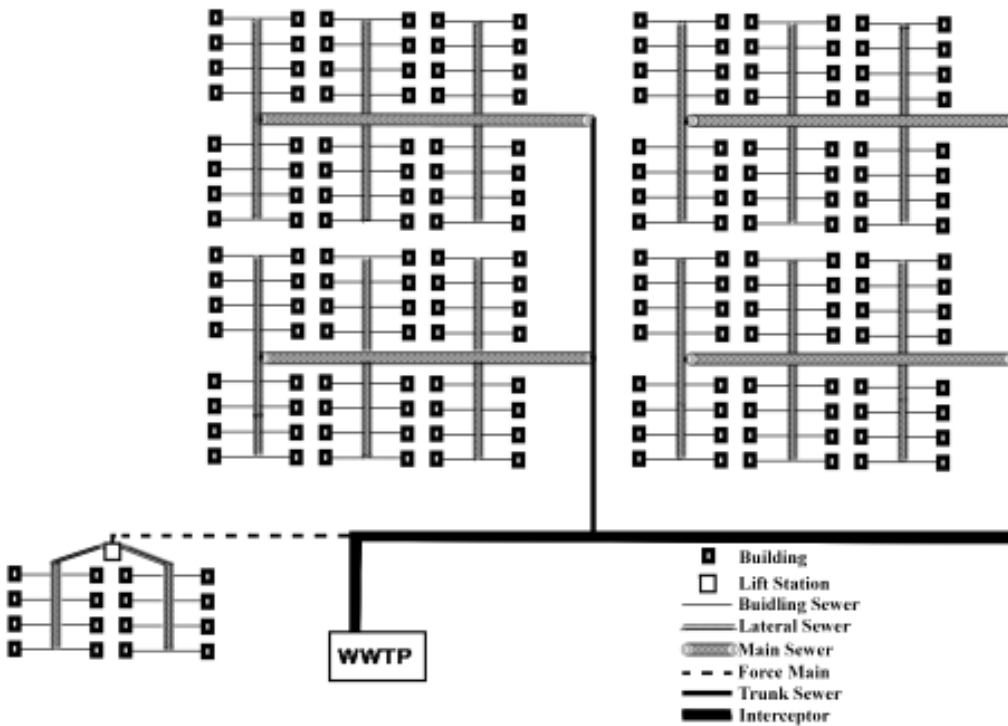
The following items are considered when determining the characteristics of a sewer line:

### Slope of Sewer

As stated before, the slope of the sewer should follow the lay of the land as closely as practical provided the slope is adequate to produce gravity flow and maintain the minimum velocity (2 fps). Some areas will be too flat to permit exclusively gravity flow because the sewer lines would have to be buried excessively deep.

### Design Flow

Wastewater collection systems are designed to convey the peak flow from a service area when the area has reached its maximum population density and has been fully developed



**Figure 4.1 - Schematic of a Typical Gravity Wastewater Collection System**

commercially and industrially. Population estimates, growth projections and comparison to similar areas are all used to determine the maximum expected volume to be contributed by a service area. Domestic wastewater flow is often calculated by multiplying the estimated population in a service area by the per capita flow. In New Mexico the per capita flow ranges from 60 to 125 gallons per day per person. Businesses and industries will contribute varying flows and so must be accounted for differently. In addition to the expected wastewater flows, allowances must be made for **infiltration** and **inflow**, (I & I are discussed later in this text). Also, because the actual flow of wastewater in the collection system will vary during a 24-hour period, (minimum flow during the early morning hours and maximum flow around 10:00 AM to 12:00 PM), a **peaking factor** must be used in order to ensure the sewer will handle the maximum instantaneous flow. Peaking factors of 2.5 – 3.5 times the total daily flow are often used to size wastewater collection systems.

### Velocity

The wastewater in a sewer line should move at a speed that will prevent the deposition and buildup of solids in the sewer; this is called a “scouring velocity”. A minimum velocity of 2 fps has been shown by experience to provide this scouring or self-cleaning velocity. Not all lines will maintain a scouring velocity at all times throughout the day. However, the sewer should be designed to provide a scouring velocity at average flows or, at the very least, during peak flows.

### Pipe Size

A sewer line should be at least large enough to allow the use of the cleaning equipment available. When sized properly, a sewer line should flow one half full during average daily flows. The air space above the half full sewer line helps to maintain aerobic conditions in the wastewater and provides some room for error in determining design flow.

### Location and Alignment

Lateral, main and trunk sewers are generally constructed near the center of public roadways so that the length of building sewers is equalized and access is convenient. Pipes are

generally laid as straight as possible to facilitate cleaning and for ease of installation. In order to avoid contamination, sewer lines must be located at least 2 *ft. vertically* below and 4 *ft. horizontally* away from potable water distribution lines.

### Depth

Sewer lines are typically placed at a depth of 4 to 8 ft. The depth and width of a trench, the backfill materials and the method of compaction determine the load placed on the sewer line and therefore influence which piping materials are appropriate.

## **WASTEWATER COLLECTION SYSTEM CONSTRUCTION**

### **PIPING AND JOINT MATERIALS**

The materials used to construct sewers are selected for their resistance to deterioration by the wastewater they convey, strength to withstand surface loads, resistance to root intrusion, their ability to minimize leakage and their cost. Great care should go in to the selection of materials and their installation because they may be in service for many, many years. The following is a list of common wastewater collection system piping materials and their attributes:

#### Asbestos Cement Pipe, (AC)

Asbestos cement is a watertight pipe that is resistant to deterioration by most types of wastewaters. AC pipe is subject to corrosion by hydrogen sulfide that combines with



moisture to form sulfuric acid near the top of the pipe, (known as “crown rot”). For this reason, AC pipe should not be used where the release of hydrogen sulfide can occur. Joints are made of sleeve and rubber gasket couplings. OSHA restricts the use of AC pipe due to its asbestos content.

**Cast and Ductile Iron, (CI and DI) Pipe**

Cast and Ductile Iron pipe is very rigid and can resist heavy surface and earth loads. Although costly, CI or DI pipe should be used for bridge crossings and where lines are shallow and subject to heavy traffic loads. Joints are typically rubber or caulk gasketed mechanical push-on type or leaded (in old installations).

**Reinforced or Non-reinforced Concrete, (RC and C) Pipe**

Reinforced and non-reinforced concrete pipe is very rigid and can withstand significant surface loads. Similar to AC pipe, it is subject to crown rot. Coal tar epoxy or plastic linings are sometimes used to retard the corrosive action. Rubber-gasketed bell and spigot joints are common but proper installation is important or they may leak. Mortar or bituminous filled bell and spigots are also used.

**Vitrified Clay, (VC) Pipe**

Vitrified clay pipe is rigid but is subject to cracking caused by root intrusion. VC pipe is resistant to acid, caustics, solvents, gases and other material that are sometimes present in wastewater. Joints usually consist of bells and spigots with factory formed resilient compression joints made of polyvinyl chloride/ polyurethane or consist of rubber couplings held in place with stainless steel compression bands (band seal couplings). Older installations used bells and spigots sealed with mortar.

**Fiberglass Reinforced, (FR) Pipe**

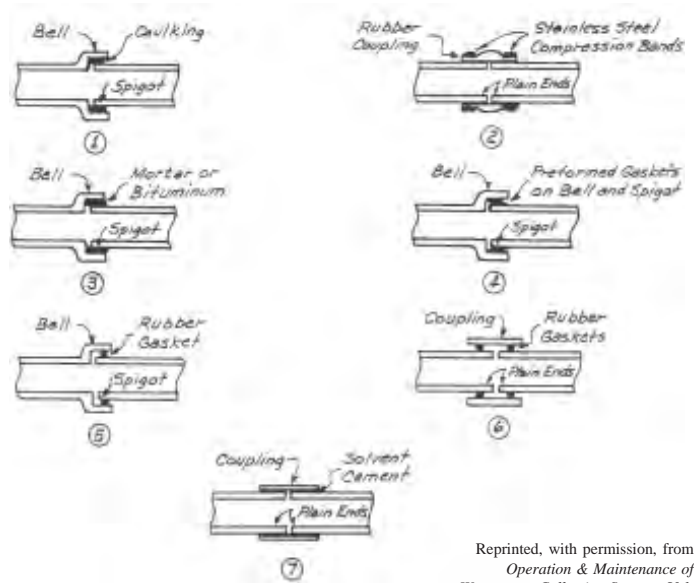
Fiberglass reinforced pipe is semi-flexible and resistant to corrosion by most compounds found in wastewaters. There is some evidence that FR pipe is subject to damage by hydrogen sulfide. Joints are made with rubber-gasketed bell and spigot. Installation should be done with great care because experience has shown this pipe to be subject to failure within several years of installation due to unanticipated surface loadings.

**Acrylonitrile Butadiene Styrene, (ABS) Pipe**

ABS pipe is flexible and resistant to most substances found in wastewater. However, petroleum products will soften and erode ABS, (these products are normally prohibited from being discharged into sanitary sewers). Joints are solvent (chemical) weld or gasketed bell and spigot. ABS pipe will deflect into an oval when improperly installed so construction inspection should ensure that cleaning tools can pass through new lines.

**High Density Polyethylene, (HDPE) Pipe**

Although relatively new, HDPE pipe is gaining in use for sanitary sewers. HDPE pipe is flexible, durable and resistant to most substances found in wastewater. HDPE is installed in long sections and thermally butt-welded in



Reprinted, with permission, from *Operation & Maintenance of Wastewater Collection Systems*, Vol. 1, 3<sup>rd</sup> ed., Office of Water Programs, California State University, Sacramento Foundation

**Figure 4.2 - Types of Joints**

Joint #	Joint description	Joint Used With:									
		AC	CI/DI	RC	C	VC	FR	ABS	HDPE	PVC	
1	Caulked Bell and Spigot		✓								
2	Band Seal Coupling		✓			✓				✓	
3	Mortar or Bituminous Filled Bell and Spigot				✓	✓					
4	Polyvinyl Chloride/ Polyurethane Pre-formed Gaskets in Bell and Spigot					✓					
5	Rubber Gasket in Bell and Spigot			✓		✓	✓			✓	
6	Rubber Gasketed Coupling	✓	✓	✓		✓				✓	
7	Solvent Cemented Coupling or Solvent Bell and Spigot							✓		✓	
8	Butt Welded (not shown)							✓			

**Table 4.1 - Common Types and Joints for Sewer Pipe**

the field. It is often used for force mains and small diameter low pressure sewer lines.

### **Polyvinylchloride, (PVC) Pipe**

PVC is flexible and resistant to most substances found in wastewater. Joints are commonly made with a rubber gasket and a factory-formed bell and spigot or a solvent cement welded coupling joint can be used in diameters up to 8 inches. Various grades are available for specific applications. Because it is inexpensive and easy to work with, PVC pipe is currently the most commonly installed pipe. However, PVC pipe is subject to damage by heavy external loads and therefore care should be given to the selection of the grade used for specific applications.

## **PIPELINE INSTALLATION**

### **EXCAVATION**

Most sanitary and storm sewers are constructed within excavated trenches. Excavation is an inherently dangerous activity. Many laws exist which pertain to excavation safety. These laws are in place to protect you! Refer to Chapter 2 Safety Practices and Regulations for an overview of excavation safety related subjects. Before beginning any excavation the nearby utility lines (natural gas, water, electric and telephone) must be identified in order to avoid damaging them. In New Mexico a free service known as New Mexico One Call is available for utility line location prior to excavation work. In Albuquerque, the phone number is 260-1990. For all other cities, towns, villages and outlying areas call 1-800-321-2537. 48 hours notice is required, (not including weekends or holidays).

If you damage utilities during an excavation you or your employer will be liable for all the associated costs and the headaches can multiply very rapidly. Most excavations are done with a backhoe, although trenching machines are becoming more popular. Situations also exist when the use of "trench-less technologies" is more attractive than an open excavation. Trench-less technologies include; in-situ pipe liners, pipe bursting, and boring and micro-tunneling machines. Some examples of their applications would be the rehabilitation of sewers with infiltration problems, sewer replacement in areas with limited access and installations where the surface over the sewer cannot be disturbed.

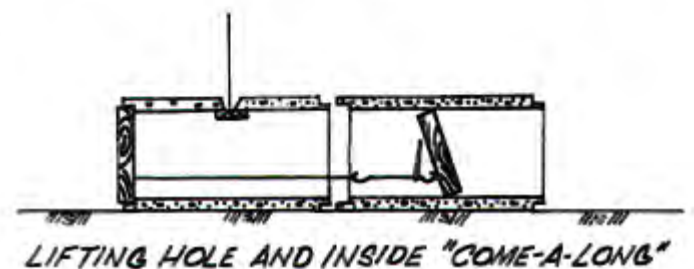
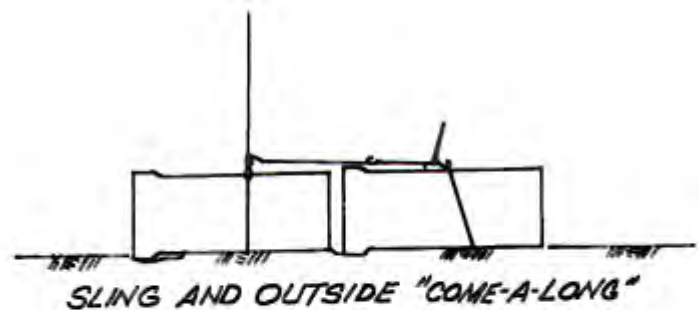
### **Controlling Line and Grade**

Line and grade controls for the sewer are used first to determine the location and depth of the sewer trench and second for laying the sewer pipe to the proper line and grade. There are several ways to establish and maintain the line and grade of the trench and pipe including; the string line method and the fixed beam laser method. Initial reference points are established using surveying equipment

and then the construction crew will use one of the methods to maintain line and grade.

### **Pipe Bedding**

Pipe placed into a trench must be properly bedded in order to properly support the pipe. This is one area that requires great care and yet is often done in a slip-shod manner. The ideal bedding material is crushed rock aggregate. Sand and pea gravel can be used but must be compacted carefully. Native material can be used but extreme care must be taken to excavate the trench bottom to true grade in order to produce an undisturbed and compacted trench bottom. Regardless of what type of bedding material is used, it is placed in the trench bottom and compacted and then carefully compacted around the sides of the pipe after the pipe has been laid. The depth of the bedding, and the bedding's compaction directly affect the load that can be placed on the pipe.



**Figure 4.3 - Methods of Pipe Joining**

Reprinted, with permission, from *Operation & Maintenance of Wastewater Collection Systems*, Vol. I, 3<sup>rd</sup> ed., Office of Water Programs, California State University, Sacramento Foundation



### Laying Pipe

Most manufacturers of sewer pipe will furnish instructions for laying and joining their pipe. Read and understand the manufacturers instructions before attempting to lay pipe.

Pipe should be handled with care to avoid damaging the joints. Only small diameter pipe (< 10 inches) should be moved by hand. Large pipe should be moved with a forklift or a backhoe equipped with a pipe sling. When installing bell and spigot pipe a small amount of bedding material should be removed to accommodate the bell so that the pipe is properly supported.

### Joining of Pipe

Differot joints of small diameter, a block and bar can be use to force uch as a “come-a-long” and sling is used. Pipe should be placed so that the bell end faces upstream. For other types of joints, refer to the manufacturers instructions for joining the pipe.

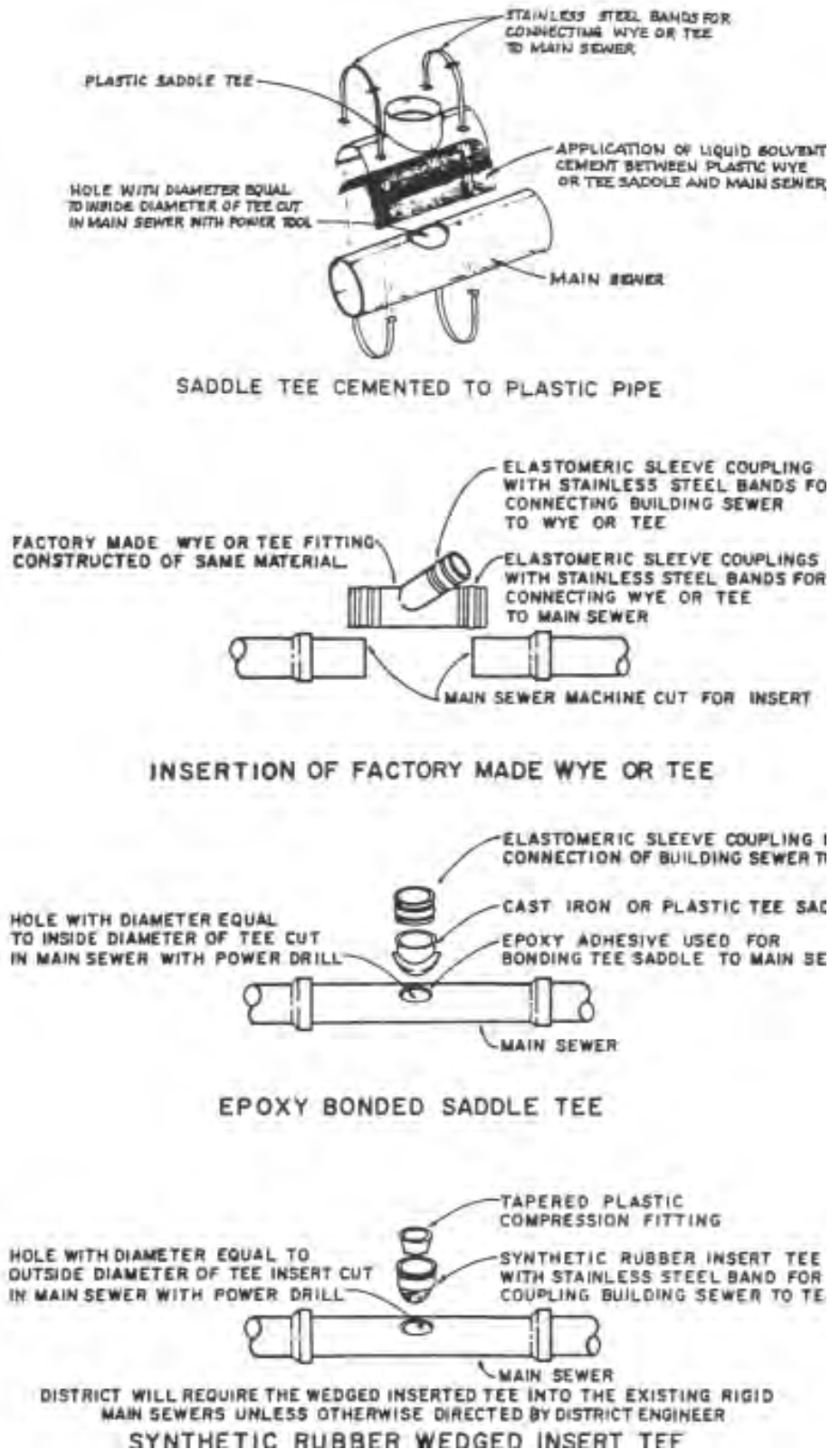
### Trench Backfilling

The placing of backfill material over the pipe has three essential elements. (1) The pipe must be protected from movement, breakage and crushing caused by the backfill material, (2) the backfill material should be compacted in layers until the excavation has been filled completely, and (3) the ground surface should be restored.

### Service Connections (Taps)

A service connection is the point of contact between the building sewer and the wastewater collection system. For new installations, taps, (known as stub-outs), are installed along with the sewer lines at places close to where future buildings are anticipated to be located. In existing systems, the collections system operators may be responsible for making new service taps to the sewer system. There are several methods of tapping into existing lines and providing stub-outs for new lines. They include; Clamp-on Saddle Tees, Insertion Wyes and Tees, Epoxy Bonded Saddle Tees, and Synthetic Rubber Wedged Insert Tees.

However service taps are made, they should provide a tight seal to prevent root intrusion and infiltration. Also, the tap should be made in such a way that the building sewer does not protrude into the sewer lateral or main. This is because



**Figure 4.4 - Building Sewer Connections (taps)**

protrusions can cause blockages and interfere with cleaning equipment.

## MANHOLES

Manholes are structures installed in lateral, main, trunk and interceptor sewers for the purpose of allowing access for maintenance and cleaning operations. Manholes are also placed at changes in sewer direction, elevation, slope, pipe size and at junctions. Drop manholes are used when the difference in elevation of an incoming and outgoing sewer line cannot be accommodated by a drop in the manhole channel without creating excessive turbulence and splashing. Manholes in straight runs of sewer lines should be spaced no farther apart than the distance that can be cleaned by the available equipment, (usually 300 – 500 ft).

Manholes are sometimes equipped with steps and sometimes entered using ladders. The corrosive gasses in the collection system can cause steps to deteriorate so use care if they are used for entry.

Be aware that manholes are considered confined spaces and their entry is therefore subject to OSHA regulations. See Chapter 2 - Operator Safety, for an overview of confined space entry regulations and procedures.

Manholes can be constructed from materials such as; brick, pre-cast concrete barrels and fiberglass. The most common manhole installation in New Mexico is the pre-cast concrete manhole with a poured in place base. Manholes of this type have six (6) constituent parts. They are:

1. A poured in place concrete base with channels and a sloped bench.
2. The inlet/ outlet piping, sealed where it penetrates the barrel section.
3. Pre-cast concrete barrels that fit together and are sealed with mortar or bituminous material.
4. A concentric or eccentric cone section.
5. Level adjustment rings for raising the grade of the manhole lid.
6. Standard tight fitting manhole cast iron ring and cover.

Figure 4.6 shows the components of a pre-cast concrete manhole.

## GRAVITY SEWER MAINTENANCE

### SEWER CLEANING METHODS

From the time that sanitary sewers were first used by early civilizations, methods of cleaning them have been employed. Because wastewater carries solids, scum and grease, collection system lines require regular cleaning to clear blockages. Collection lines also provide an ideal place for roots to grow and therefore blockages caused by root intrusions are very common. There are many ways to clean sewer lines. Some are more effective on grease, some on roots and others on sand and sediment blockages. The methods employed around New Mexico often have as much to do with tradition as with economics and effectiveness. The following sewer cleaning methods are common to New Mexico:

#### Hand Rodders

Hand rodders represent the oldest style of cleaning equipment. Hand rodders are typically made of a coil of spring steel or attachable segments of spring steel that can be forced into a sewer line to dislodge a blockage. Because they are non-mechanical they are reliable, however some blockages, such as roots, are difficult to clear with hand rodders. Also, hand rodders are typically limited in length to around 100 ft and therefore their effectiveness is limited to their length and the eagerness of the operator. Because they can be used in areas where the access to the sewer is limited hand rodders should be a part of every collection

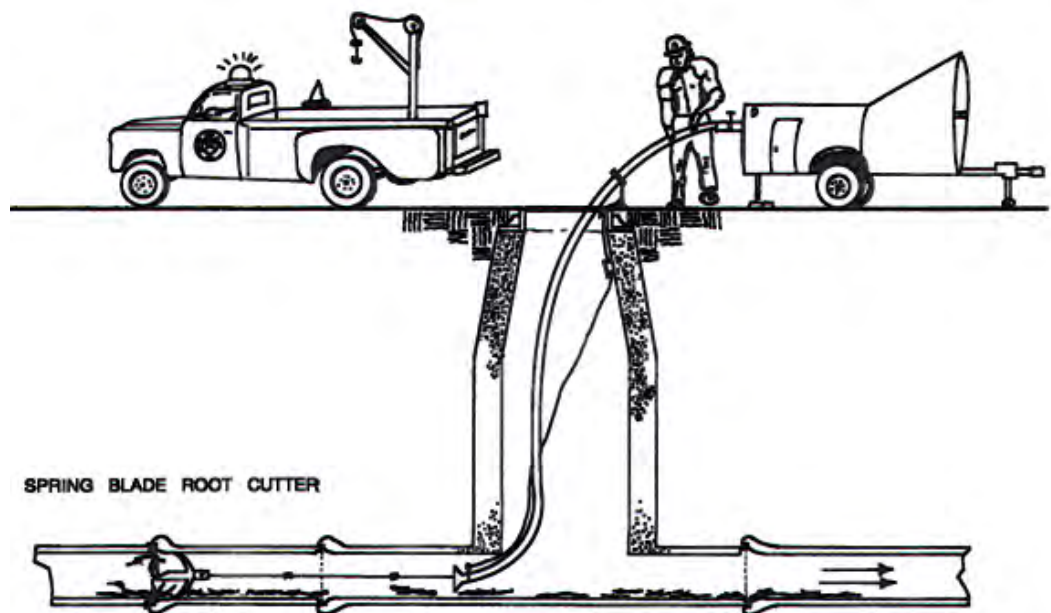


Figure 4.5 - Power Rodder Operation

Reprinted, with permission, from *Operation & Maintenance of Wastewater Collection Systems*, Vol. I, 3<sup>rd</sup> ed., Office of Water Programs, California State University, Sacramento Foundation



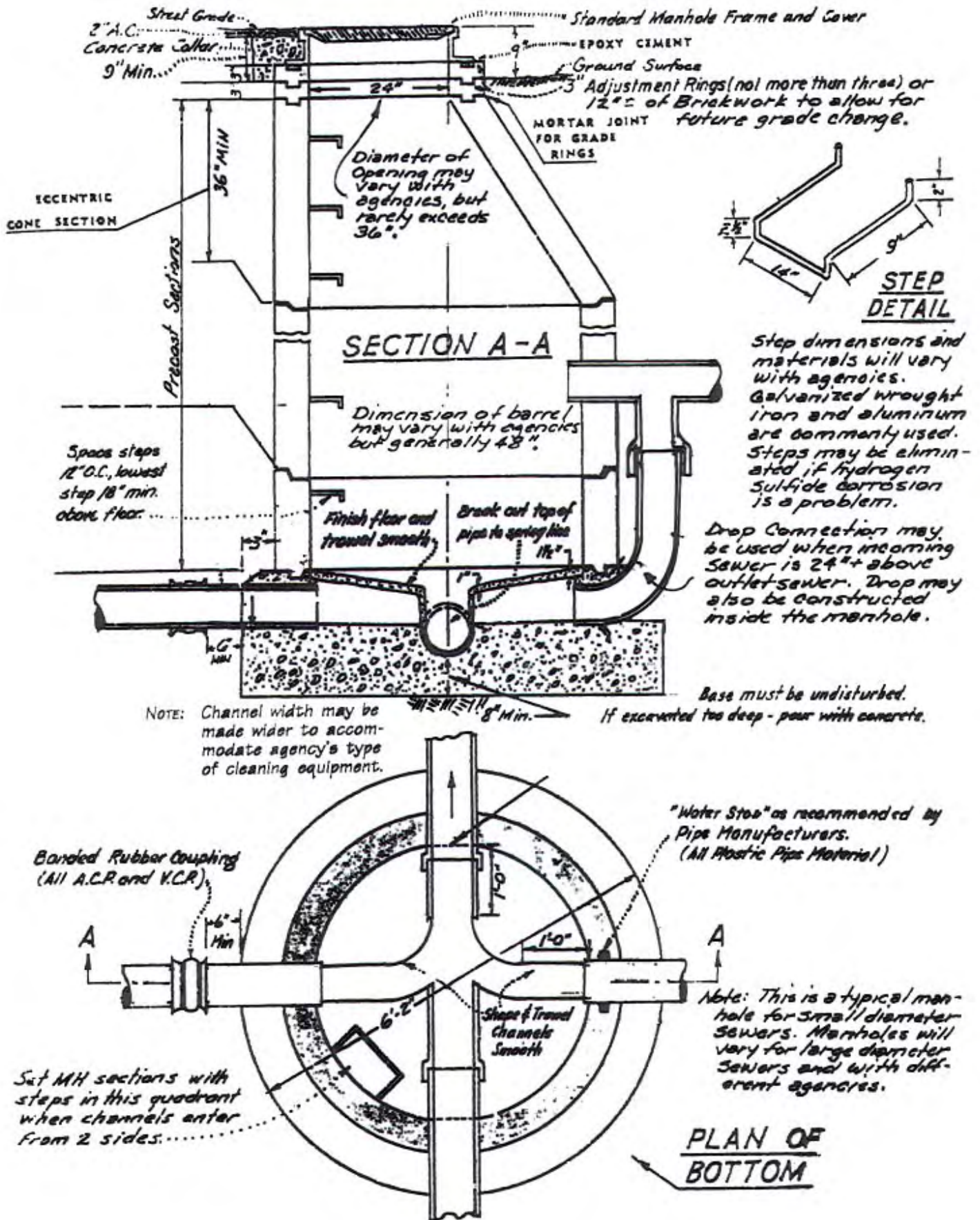


Figure 4.6 - Pre-Cast Concrete Manhole

Reprinted, with permission, from *Operation & Maintenance of Wastewater Collection Systems*, Vol. I, 3<sup>rd</sup> ed., Office of Water Programs, California State University, Sacramento Foundation

## SEWER RODDING TOOLS AND USES



### ROUND STOCK CORKSCREW

For rodding through sewers where conditions are unknown.



### SAND LEADER

Used to guide rods across the top of built-up materials in the line by the flipping action of blades.



### SQUARE STOCK CORKSCREW

For removing heavy root growth. Sharpened cutting edge will tear loose roots and remove other rigid obstructions when pulled backwards.



### ROOT SAW

Used for power sawing of stubborn root masses in the sewer pipe.



### DOUBLE CORKSCREW

A double-pronged tool to remove miscellaneous obstructions.



### SPRING BLADE ROOT CUTTER CHUCK

This cutter with the proper size blades is used in preventive maintenance work in sewers. should be rotated at high speed (Power Rodding Machine) and PULLED slowly through the line while rotating to effect a thorough scouring of the pipe. NOTE: This tool is not designed to be pushed into a sewer line.



### DOUBLE SAND CORKSCREW

The boring action of the corkscrew helps to pull rod through lines impacted with sand, gravel, and similar buildups. This tool must be kept moving since it may settle into built-up material and become stuck.



### AUGER

This tool is useful for cutting long strungy roots and for loosening sedimentary deposits in sewer pipe.



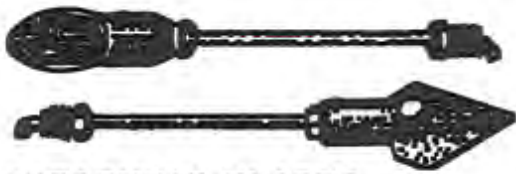
### PORCUPINES

The turn-type porcupine is used in lines up to 12 inches in diameter. Its function is to scour lines of light buildups in conjunction with water flushing of sewer lines.

Figure 4.7a - Sewer Rodding Tools and Uses



# SEWER RODDING TOOLS AND USES



## SPEARHEAD BLADES

Used in small pipes to remove hard deposits and break up hard obstructions such as glass, bottles, cans, and plaster.



## BULLET NOSE

It's designed to be screwed into end of coupler for least resistance when rodding through heavy roots.



## PICK-UP TOOL

Used to snare broken sectional sewer rods.



## ASSEMBLY WRENCH

Used for holding and turning nuts and couplers in assembly rods and tools.



## RATCHET TURNING HANDLE

Used with locking pin through pullout tool and coupler to turn rods.



## PULLOUT TOOL

Used to encircle rod coupler to push rods into or pull rods out of line.



## ASSEMBLY TURNING HANDLE

Used for assembling nuts and couplers for turning rods; spring loader pin engages hole in coupler.



## BAR TURNING HANDLE

Used to secure into hole in coupler for turning, pushing, and pulling rods.



## ROD END SWIVEL

Used for pulling cables and wires through a pipe and is designed to be free turning under load at the end coupling.

Reprinted, with permission, from *Operation & Maintenance of Wastewater Collection Systems*, Vol. I, 3<sup>rd</sup> ed., Office of Water Programs, California State University, Sacramento Foundation

Figure 4.7b - Sewer Rodding Tools and Uses

system operator's toolbox, no matter how large or small the system is.

### **Power Rodders**

Power rodding machines use a rotating steel rod or flexible cable to turn a rodding tool in the sewer line to clear blockages.

Steel rods are either continuous or sectional, flexible cables are continuous but can have sections added to increase their length. Both are stored in a reel-type cage that allows them to be fed out while rotating. The rotating reel may be driven by a motor, a small engine or a power take off (PTO). A variety of power rodder tool heads exist for clearing different types of blockages.

Power rodgers are typically mounted on a specialized truck or trailer that includes storage for tools, various cutters, etc. Power rodgers are capable of clearing the worst blockages caused by roots, grease and sediment. After a line has been cleared with a power rodder it should be flushed or hydraulically cleaned to restore full flow capacity.

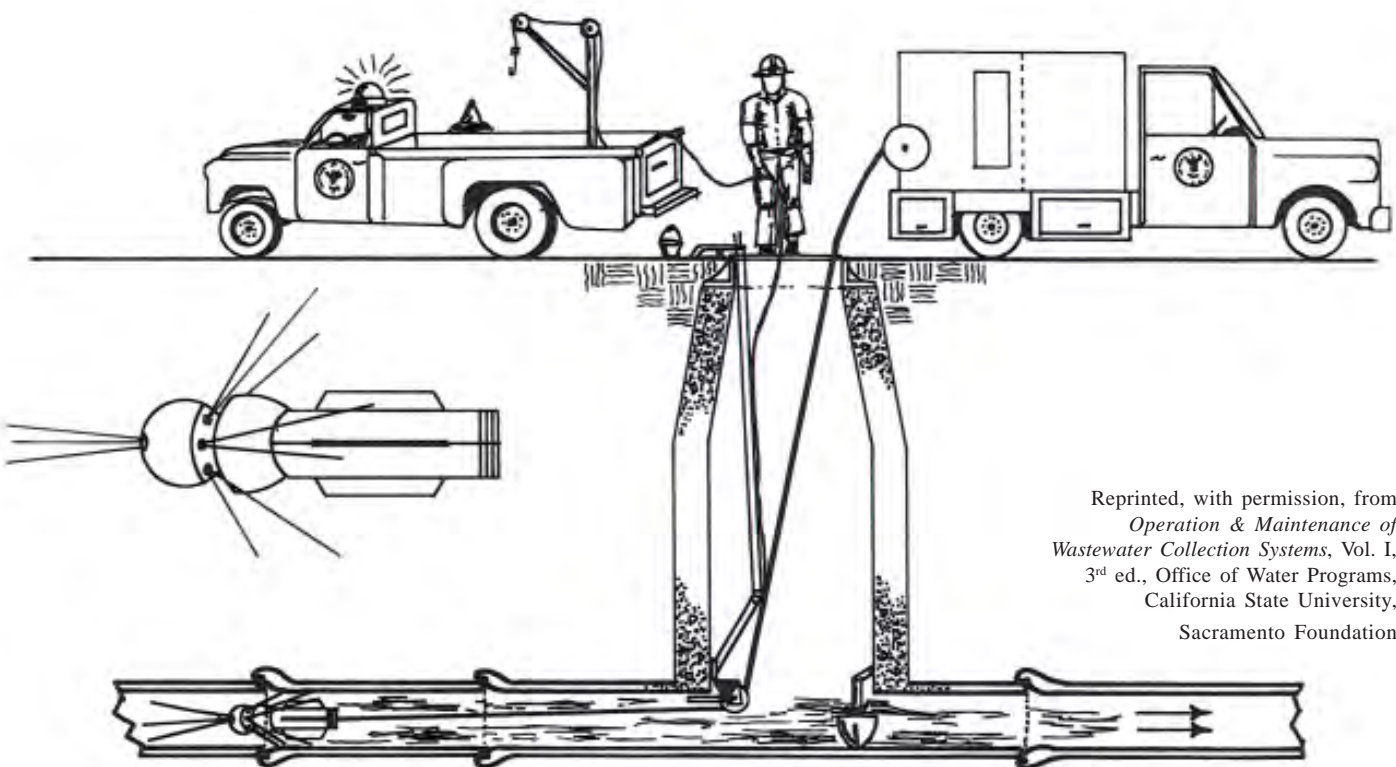
### **High Velocity Hydraulic Cleaning Machines, (Jet Rodders)**

High velocity hydraulic cleaning machines, (also known as jet rodgers), use water pressure to propel a nozzle and its attached hose through the sewer line. The nozzle is equipped with jets that scour debris loose and move it toward a manhole where it can be removed. Jet rodgers consist of

a water supply tank, a high-pressure pump and an auxiliary engine for driving the pump. These units have a powered drum reel capable of holding at least 500 ft of hose, (usually one-inch I.D. for large machines). Many different nozzles are available for accomplishing different cleaning chores. These machines can be mounted on a small trailer or a purpose built truck. They are commonly mounted on a utility vehicle that combines a jet rodder and a vacuum device for removing grit and debris from the sewer. Jet rodgers are effective at opening blockages and removing grease or sediment. With a root cutting attachment they can remove roots from sewer lines, although they are not usually as effective as a power rodder at this task. One added benefit of jet rodding machines is that with a wash down gun attachment they can be used to clean manholes and lift stations and for other cleaning jobs where pressurized water is not easily available.

## **PERFORMING CLEANING AND MAINTENANCE OPERATIONS**

Pipeline cleaning and maintenance operations fall into one of three categories, these are preventive maintenance, emergency clearing of line blockages (sewer back-ups) and emergency repairs to the system. The old adage "an ounce of prevention is worth a pound of cure" is certainly true when it comes to collection systems preventive maintenance.



Reprinted, with permission, from  
*Operation & Maintenance of  
Wastewater Collection Systems*, Vol. I,  
3<sup>rd</sup> ed., Office of Water Programs,  
California State University,  
Sacramento Foundation

**Figure 4.8 - Jet Rodder - High Velocity Cleaning Operations**



Pipeline cleaning preventive maintenance programs generally have three aims:

1. Minimize the number of stoppages per mile of sewer.
2. Minimize the number of odor complaints.
3. Minimize the number of lift station failures.

Preventive maintenance can include activities such as; cleaning problem areas to avoid line blockages, chemical treatments to prevent root growth and removal of sediment from lines and manholes. If the preventive maintenance program is well thought out and conducted on a regular basis, problems in the collection system will be minimized. This will result in fewer sewer back-ups, a reduction of odors (and the resulting complaints) and lift station call outs will be reduced. All individuals served by the collection system benefit from these reduced problems but it is the operator that has to deal with a lift station failure or a sewer back-up (always on Super-Bowl Sunday) that benefits the most from preventive maintenance.

Unlike preventive maintenance activities that are performed even when the system is working well, dealing with sewer back-ups and making emergency repairs involves returning the system to operation. When an operator encounters a sewer back-up the aim should be to correct the problem as quickly as possible. Finding the best method of correcting the problem comes first. Things to consider include:

- Does this line have a history of previous stoppages? (A root or grease problem for example).
- Are trees growing near the line?
- Has a new connection been installed in the area recently?
- Have repairs been made recently either to the sewer or to other utilities or the street?
- Are there any ground or surface indications, such as settlement or a sinkhole?

With these things considered the best approach to correcting the problem can be chosen. Usually rodding operations are conducted from the manhole immediately downstream of the blockage rodding upstream toward it. This allows easy access to the line (it is not submerged under wastewater) and provides the best position to remove debris that is released by the cleaning operation. This debris (roots, grease, sand and sediment) should not be allowed to move further down the collection system because it will likely cause another blockage. If a large blockage has been cleared and it is obvious that a large amount of septic wastewater was trapped behind the blockage the operators of the wastewater treatment plant should be notified so that they can take actions that will help the treatment plant accommodate the septage.

Because of traffic control and safety issues collection system work such as clearing sewer back-ups and emergency repairs should be performed by a minimum of two operators.

## **RECORDS**

Whenever a blockage is cleared or a repair or maintenance activity has been performed a complete record should be made for future reference. The record should include all the important information including where and when the incident occurred, distance and cause of blockages, line size, manhole number and a note on the kind and amount of material removed.

## **LIFT STATIONS**

### **PURPOSE OF LIFT STATIONS**

Lift stations are used to raise wastewater from a lower elevation to a higher elevation. Pumps are used to move wastewater through a discharge pipe known as a force main. After discharge from the force main, wastewater resumes gravity flow. The location and design of lift stations is decided by economics and practicality. Some of the reasons that a lift station may be required include;

- Excavation costs to maintain gravity flow and scouring velocity become excessive.
- Soil stability is unsuitable for trenching.
- Ground water table is too high for installing deep sewers, and
- Present wastewater flows are insufficient to justify extension of sewer main and lift station offers economical short-term solution.

Lift stations should be designed to move the wastewater with maximum efficiency. The pumps size and type should be selected to provide the most constant flow rate possible to minimize surges of flow at the downstream gravity sewer or the wastewater treatment plant. The appearance should blend in with the surrounding area and odors, noise and rubbish should be dealt with immediately.

### **TYPES OF LIFT STATIONS**

Lift stations can be described with two broad categories: Wet Well type and Dry Well type.

#### **Dry Well Lift Stations**

Dry well lift stations contain two chambers. One for collecting the wastewater before it is pumped and the other to contain the pumps, motors, valves, electrical controls and auxiliary equipment in a dry well where access is easy for service. Dry well lift stations range in size from just large enough for a man to enter to large installations that may even be constantly manned.

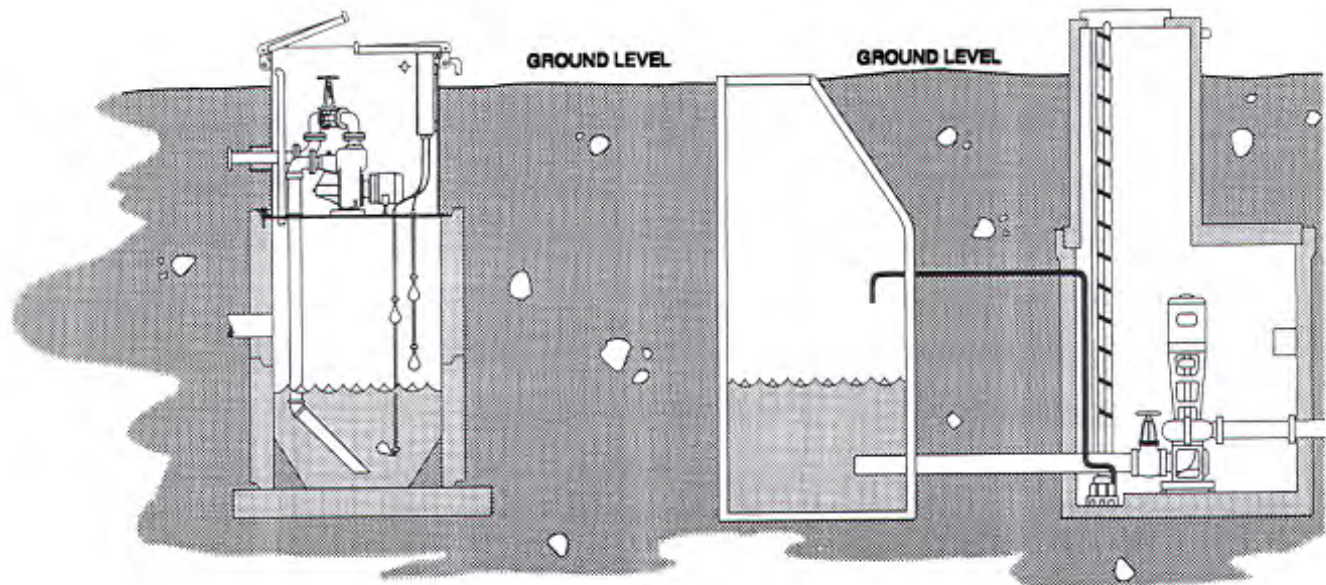
### Wet Well Lift Stations

Wet well lift stations contain only one chamber, the wet well where wastewater is collected before it is pumped. The pumps may be located above the wet well, (which is known as a suction lift pumping arrangement), or the pumps

may be located inside the wet well itself, (submersible pumps). Both locations have their advantages and disadvantages. Suction lift pumps can be above ground or in a shallow pit where they can be easily serviced and repaired, but these types of pumps are prone to losing their

### **Sewage Lift Station**

Dynamic pumps are often classified by suction conditions. In wastewater there are commonly two types of lift stations: **dry well** and **wet well**. The primary difference between the two is the number of tanks. The wet well has one tank and the dry well has two.

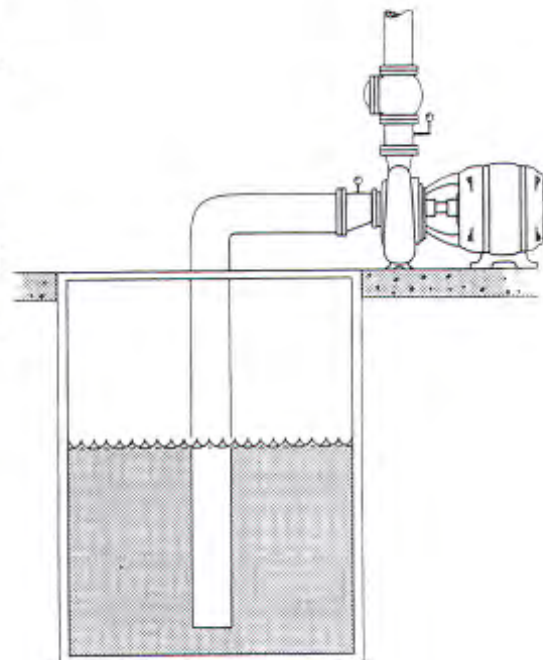


**Wet Well Lift Station**

**Dry Well Lift Station**

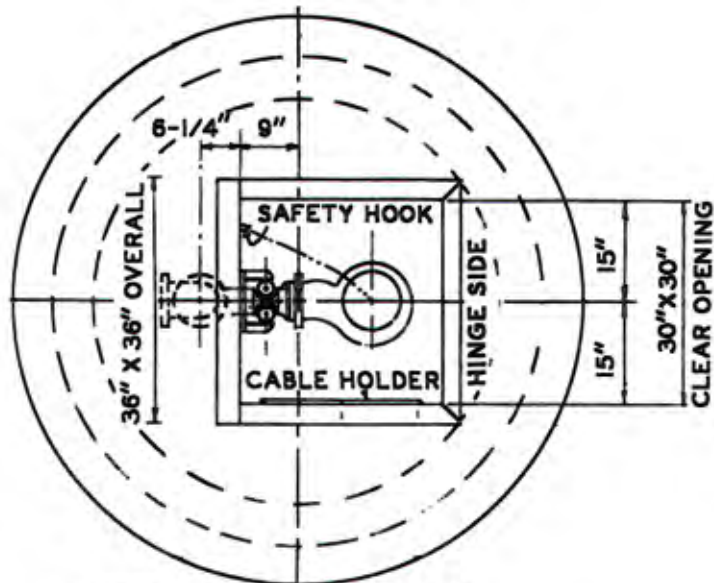
### **Wet Well Suction Lift**

When the pump is placed above the level of water from which you intend to pump, the pump is said to be in a **suction lift condition**.



**Figure 4.9 - Sewage Lift Stations**





PLAN VIEW GRADE ELEVATION

**NOTE:**  
 CONFIGURATION AND DIMENSIONS SHOWN ARE SUGGESTED MINIMUM REQUIREMENTS ONLY. ALL DETAILS, INCLUDING SIZING OF PIT, TYPE, SIZE, LOCATION AND ARRANGEMENT OF VALVES AND PIPING, ETC. ARE TO BE SPECIFIED BY THE CONSULTING ENGINEER AND ARE SUBJECT TO HIS APPROVAL

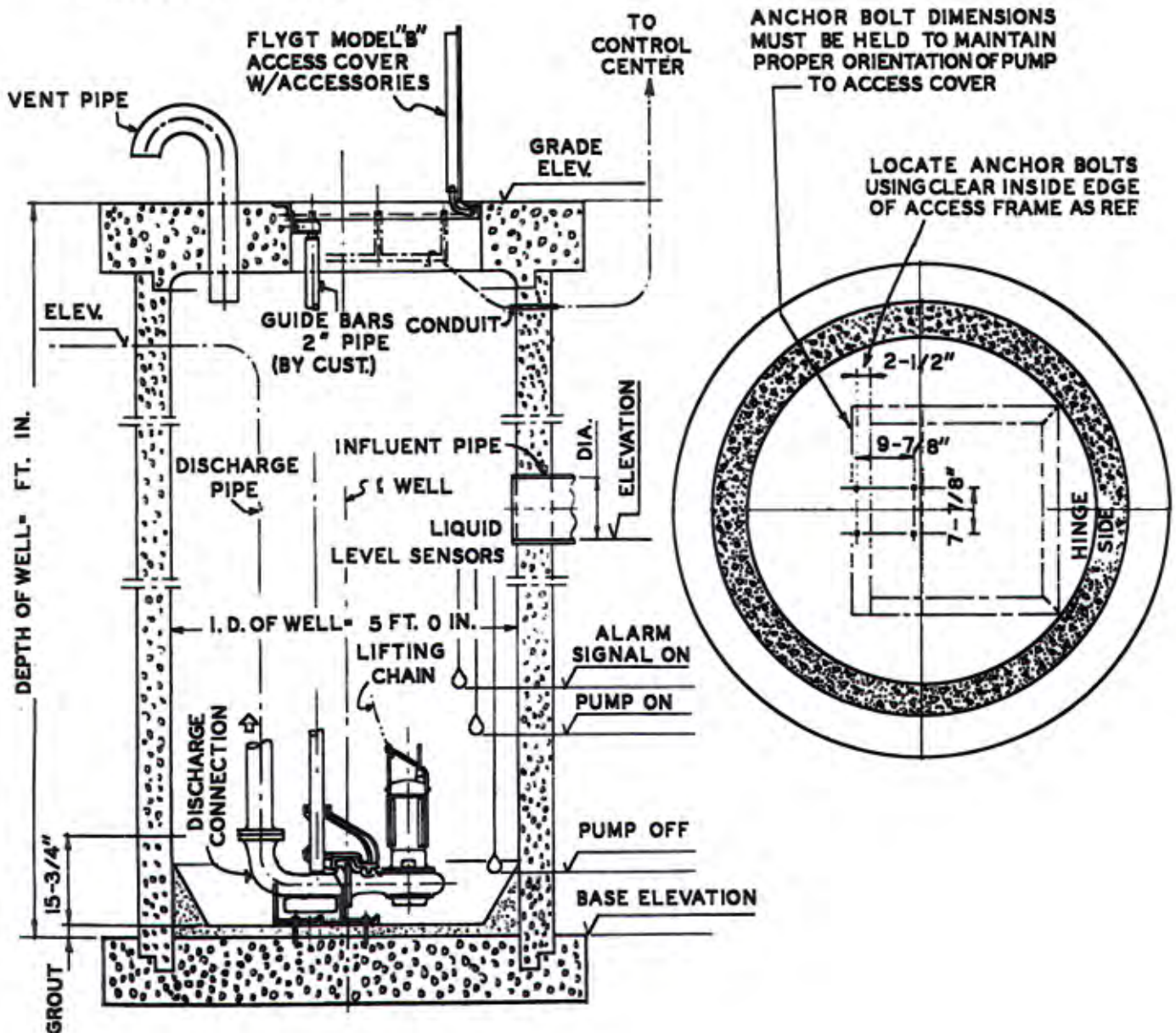


Figure 4.10 - Submersible Pump in Wet Well

prime, particularly when they age. If a pump loses prime, the motor will run and the impeller will turn but the pump will not in a shallow pit where they can be easily serviced and repaired, but these types of pumps are prone to losing their prime. Submersible pump installations never lose prime because the pump intakes always have standing water over them (suction head condition). However, because the pumps are located in the wet well they can be hard to access if not designed properly. Equipment located in the wet well should be kept to a minimum. Discharge valves, check valves and other equipment that requires periodic maintenance should be located in a concrete vault or small room adjacent to the wet well. When submersible pumps are used in wet well lift stations they should be designed to be removed from the surface without entry into the wet well, (which is considered a confined space).

## **LIFT STATION COMPONENTS**

### **Pumps**

Lift stations generally employ centrifugal pumps, pneumatic ejectors or screw type pumps, (centrifugal pumps are the most common in New Mexico). Review Chapter XXX, Pumps and Motors for information of pump configuration, operation and maintenance.

### **Wet Well**

The wet well can be constructed of pre-cast concrete rings (similar to manhole rings), poured in place concrete, fiberglass or metal. It should be designed to withstand characteristics common in the wastewater it will pump. The wet well should be sized so that the pumps will not have to cycle too often, which can cause unnecessary wear, yet not so large that the wastewater becomes septic due to excessive holding times. (This can also be altered to some extent by changing the operating levels by adjusting the pump controls).

### **Hardware**

The hardware uses in lift stations should be either high-grade aluminum or stainless steel to prevent corrosion.

### **Bar Racks**

It is often desirable to include a bar rack at the inlet to the wet well of a lift station to catch large objects and rags before they enter and damage the pumps. If bar racks are included they must be made of the appropriate material (aluminum or SS) and they must be easily cleaned without entry into the wet well.

### **Dry Well**

Dry well structures commonly have two or more floor levels. Pumps and valving are located on the lowest level while electrical controls and motors are often located on

an upper level. A sump pump is provided to removed seal water or any water that leaks into the dry well. Ventilation and atmospheric monitoring are provided to prevent dangerous conditions from developing.

### **Valves**

Valves are of critical importance to lift station O & M but they are frequently neglected, abused, misused and installed at improper locations. The major valves found in wastewater lift stations are:

- Pump suction and discharge isolation valves (gate valve, plug valve or knife valve). Isolation valves are used to section off the pump when service is required. These valves should not be used to throttle (control) the flow into or out of the pump because the valve and pump could be damaged.
- Discharge check valves, (swing check or ball check valves). Check valves prevent water from flowing backward through the pump when the pump shuts off. Hard closing or noisy check valves indicate that something is wrong, such as air trapped in the force main.
- Cross connection control valves. These are discussed later in this text.

### **Electrical Systems**

All but the smallest lift stations are provided 3-phase electrical service so that the system will work efficiently and for practicality. Many lift stations have emergency back-up generators to maintain pumping during power outages. If a generator is not provided a transfer switch should be included so that a portable generator could be rapidly hooked up to maintain pumping during times of loss of power.

### **Alarms**

Because the failure of a lift station could result in damage to homes, property and the environment all lift stations should be equipped with some type of audible and visual alarm at a minimum. For large installations a computer will automatically contact operators in the event of a failure or the system will be monitored through telemetry. A “high water alarm” should be included for every installation.

### **Motor Control Center (MCC)**

The pump motor controls are located in a motor control center. This is typically an electrical box with switches for operating the pumps in either hand (manual) mode, in automatic mode or for turning them off. For this reason these are known a H-O-A switches (Hand-Off-Auto). MCC panels usually include pump starter coils, which allow the 110 V switch to engage the higher voltage motor circuit and a system for alternating lead and lag pumps. Alarm lights and reset buttons will also be located on the MCC panel.

## **Hours Recorders**

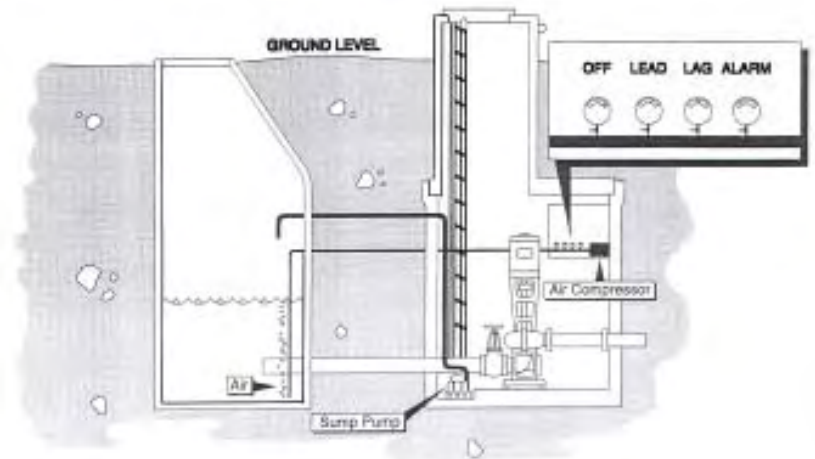
The pumps in a lift station should be equipped with equipment hours recorders so that the total run time of each pump can be compared. If one pump in an automatic alternating duplex lift station runs much more than the other it is a indication that something is wrong, such as a leaking check valve. Also, flow through the lift station can be established if the pumping rate and operating hours are known.

## **Pump Controls**

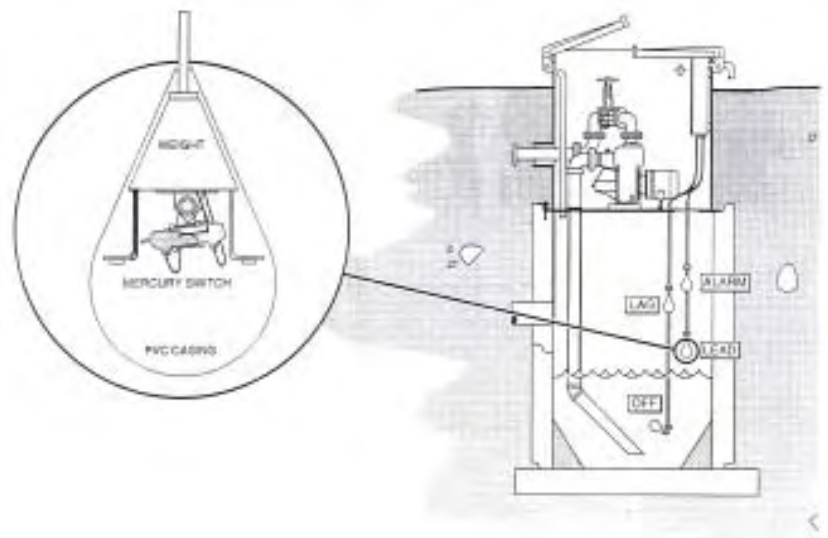
All lift station pump controls are similar in that they control the pumps based on the level of water in the wet well. Controls vary greatly in how they accomplish the task. Common lift station control systems used in New Mexico include:

- Float controllers. Floats are one of the oldest pump control devices. As the water in the wet well rises, the float (a ball attached to a rod) rises with it until a switch is triggered which turns the pump on. When the pump lowers the level to a pre-set point an actuator shuts the pump off.
- Electrode Controllers (probes). Electrode controllers utilize electrode probes or leads that are an open circuit until the water level rises, wetting both electrodes and allowing current to flow which enacts the control circuit on the pump to turn it on. When the water level drops and the upper probe becomes exposed, the circuit opens and the pump shuts off. This type of control is subject to problems caused by grease and rags.
- Pneumatic Controllers (bubblers). Pneumatic controllers work by sensing the pressure required to force air bubbles out of a tube located near the bottom of the wet well. When the wet well is full, it takes more pressure to force bubbles out of the tube (due to the higher head created by the standing water). The on off set points for the pumps on this type of controller are actually pressure set points. Bubblers rely on an air pump, similar to a fish aquarium pump, to provide air so that the pressure can be measured as bubbles are forced out the tube near the bottom of the wet well. If the tube becomes clogged by a rag or grease, or the air pump fails the system will stop working. If the length of the bubbler line changes, (accidental damage while removing a pump for example), the system will function incorrectly, if at all.

- Mercury Float Switches. Mercury float switches are one of the most common types of lift station controls. They consist of a float that contains a sealed chamber with two electrodes and a small amount of mercury (quicksilver). When the float is in one position (vertical, while hanging for example) the mercury is pooled away from the electrodes and the circuit is open. When the float is tilted to the other position (horizontal, while floating) the mercury flows down to the electrodes and the circuit is completed which triggers the pump control to turn the pump on. Mercury float switches can be purchased as either normally open (on switch) or normally closed (off switch) when in the vertical position. The floats must be kept clean so that they will tilt when



**Figure 4.11 - Pneumatic Controllers**



**Figure 4.12 - Mercury Float Switch**



floating and they must be lowered carefully back down into the wet well after they have been cleaned and checked.

### **Force Mains**

A force main is the discharge line for the lift station. The discharge lines of the pumps come together in a manifold and then enter the force main. Air accumulation in force mains can create a problem known as a water hammer, which is a high pressure shock wave that travels up and down a force main. This problem is associated with pump check valves slamming, sometimes repeatedly, which causes damage to valves and piping. Air release valves are normally installed at the high points in force mains to automatically blow off accumulated air.

### **TROUBLE SHOOTING LIFT STATION PROBLEMS**

Lift station problems can be summarized in the following four categories:

1. Power [power outage, electrical circuit failure, motor burned out].
2. Control System [pump control failure, telemetry system failure].
3. Pumping System [pump failure].
4. Structural [grit deposits, plugged force main or check valve].

Experience is often the best tool in the operator's toolbox when it comes to trouble shooting. All but the very simple electrical problems (changing fuses) should be left to a licensed electrician unless proper training has been given to operators. Most lift station failures can be prevented through a well thought out preventive maintenance program.

### **INFILTRATION AND INFLOW (I & I)**

Ground water that enters into the sewer system through broken joints and leaking manhole barrels is referred to as infiltration. Storm water that enters manhole covers and illegal connections like gutter drains routed into house clean outs is known as inflow. Both infiltration and inflow can contribute significant amounts of water to the wastewater collection system. Once in the collection system the I & I becomes wastewater that must be treated by the treatment plant. Some treatment plants become hydraulically overloaded during storm events from inflow or during the spring run-off from infiltration. Because of this the identification and control of infiltration is important to the wastewater collection system operator.

### **IDENTIFICATION OF I & I**

Studies conducted to identify I & I can be very elaborate involving engineering consultants and costing large amounts of money or they can be basic and conducted by system operators. The size of the system and the extent of the problem will dictate what measures are necessary.

Methods that are commonly used for identifying the location and extent of infiltration and inflow are:

- Late Night Survey. Very little flow should be occurring in the collection system in the early morning hours (2:00 AM – 4:00 AM). By surveying manholes for clear water that is near ground temperature a generalized idea of the extent of infiltration can be made. (This may not work in all areas of larger systems).
- Closed Circuit Television (CCTV) inspection. CCTV inspection is often used to identify infiltration problems. A purpose built camera is inserted into the collection lines and the line is video taped so problem areas can be analyzed. A thorough line cleaning prior to video tapping is very important.
- Smoke Testing. Smoke testing is used to identify broken joints and leaking manhole barrels that could allow infiltration to enter the system and to identify illegal taps (customer not paying sewer fee) or connections to the sewer system that would allow storm water to enter. For this test smoke is forced into the collection system by an engine driven fan located over a manhole opening.
- Flow Records. Wastewater treatment flow records often are used to identify storm events that introduce inflow into the collection system. Also, flow records that show a constant early morning flow during periods of run-off can be used to identify infiltration. Chart recording flow measurement devices allow the volume and duration of I & I to be characterized.

### **CONTROL OF I & I**

Numerous methods are available to designers and engineers to correct infiltration and inflow problems once they have been identified. These include sewer replacement, slip lining (in-situ form), pipe bursting, chemical grouting and improvement of storm sewers.

Not many of these options are within the capabilities of the average collections department, so contractors most often perform them. Collections crews do have the ability to minimize some infiltration and inflow problems, such as repairing or replacing individual deteriorated manholes, raising manhole rings and covers in area that flood, and repairing broken joints when they are discovered. Whenever possible, collection system operators should work to limit I & I so that the treatment plant can perform its job of treating wastewater.



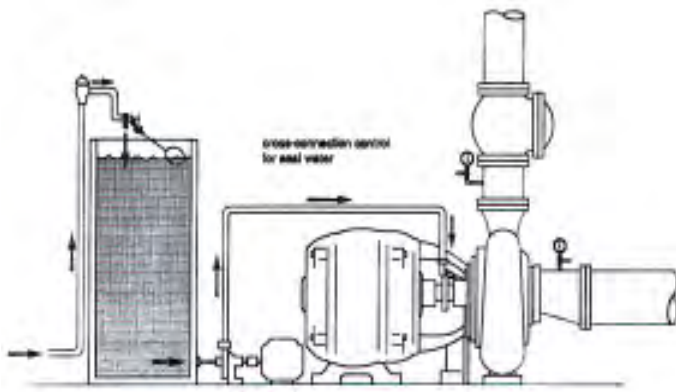


Figure 4.13 -  
*Air Gap for Cross-Connection Control*

### **CROSS CONNECTION CONTROL**

A cross connection is connection between a potable (drinking) water system and water from an unsafe or unknown source. A common place in wastewater collection systems where this can occur is on the seal water line for a lift station pump. When potable water is used as the seal water supply and a no protection is in place, a direct cross connection exists. Without protection, wastewater from inside the pump could enter and contaminate the potable water system. Several devices for controlling cross connections exist.

The use of these devices is related to the “degree of hazard” that exists to the potable water system. An air gap device offers the highest degree of protection and is commonly used in wastewater applications.

Several excellent programs are available to train operators about the dangers of cross connections and the devices used for control cross connections.

### **AS-BUILT PLANS**

At the start of a sewer construction project, the inspector should obtain two sets of the plans for the project. One copy is the working plan that will be used to guide the construction project. The other copy is known as the “as-built” plans. Any daily construction that deviates from the working plan should be recorded on the as-built plan by the inspector. This plan then becomes the true record of where stub-outs and taps are placed, where lines and manholes are located, etc.

The as-built plans reflect what actually exists underground. Because of this fact, they are invaluable to the collection system operators. When a project is completed, the as-built plans are submitted to the project engineer who either

files them directly or has a revised drawing made. These plans should always be kept available to collections system workers.

All too often few or no maps exist of the wastewater collection system. Although some collections workers may feel that this offers “job security”, the headaches brought about by not having proper plans to work with probably offsets this feeling.

### **References**

- Office of Water Programs, California State University, Sacramento, *Operation & Maintenance of Wastewater Collection Systems*, Vol. I, 3<sup>rd</sup> ed., Chapters 1 – 7
- Office of Water Programs, California State University, Sacramento, *Operation & Maintenance of Wastewater Collection Systems*, Vol. 2, 5<sup>th</sup> ed., Chapter 8

# CHAPTER 5: WASTEWATER TREATMENT PONDS

## USE OF PONDS

Shallow ponds (3 to 5 feet) are often used to treat wastewater and other wastes instead of, or in addition to, conventional waste treatment processes. When discharged into ponds, wastes are treated or stabilized by several natural processes acting at the same time. Heavy solids settle to the bottom where they are decomposed by bacteria in suspension. Some wastewater is disposed of by evaporation from the pond surface.

Dissolved nutrient materials, such as nitrogen and phosphorus, are used by green algae which are actually microscopic plants floating and living in the water. The algae use carbon dioxide (CO<sub>2</sub>) and bicarbonate to build body protoplasm. In so growing, they need nitrogen and phosphorus in their metabolism much as land plants do. Like land plants, they release oxygen and some carbon dioxide as waste products.

Ponds can serve as very effective treatment facilities. Extensive studies of their performance have led to a better understanding of the natural processes by which ponds treat wastes. Information is provided here on the natural processes and ways operators can regulate pond processes for efficient waste treatment.

## HISTORY OF PONDS IN WASTE TREATMENT

The first wastewater collection systems in the ancient Orient and in ancient Europe discharged wastewater into nearby bodies of water. These systems accomplished their intended purpose until overloading, as in modern systems, made them objectionable.

The first ponds constructed in the United States were built for the purpose of keeping wastewaters from flowing into places where they would be objectionable. Once built, these ponds performed a treatment process that finally became recognized as such.

As a complete process, the ponding of wastewater offers many advantages for smaller installations. This is true provided that land is not costly and the location is isolated from residential, commercial, and recreational areas.

The advantages are that a pond:

1. Does not require expensive equipment
2. Does not require highly trained operation personnel
3. Is economical to construct
4. Provides treatment that is equal or superior to some conventional processes
5. Is adaptable to changing loads
6. Is adaptable to land application

Table 5.1

PURPOSE OF POND PARTS

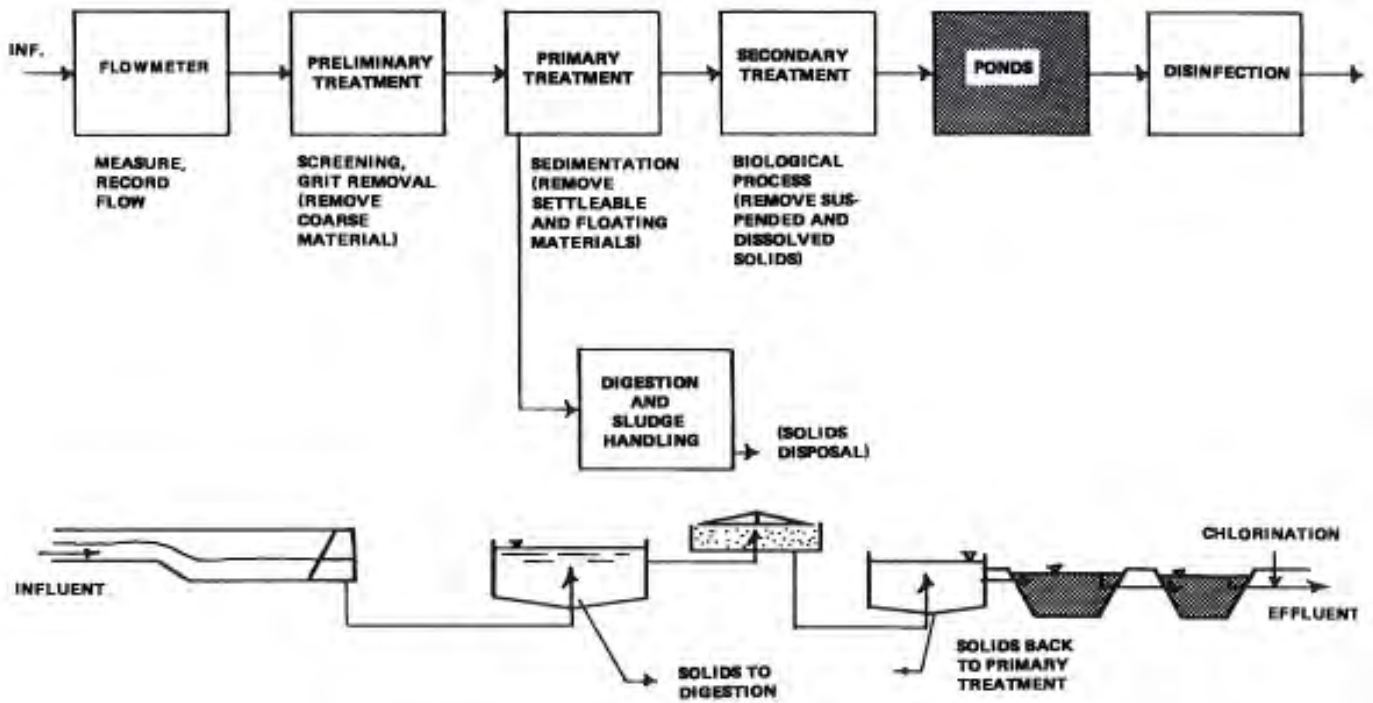
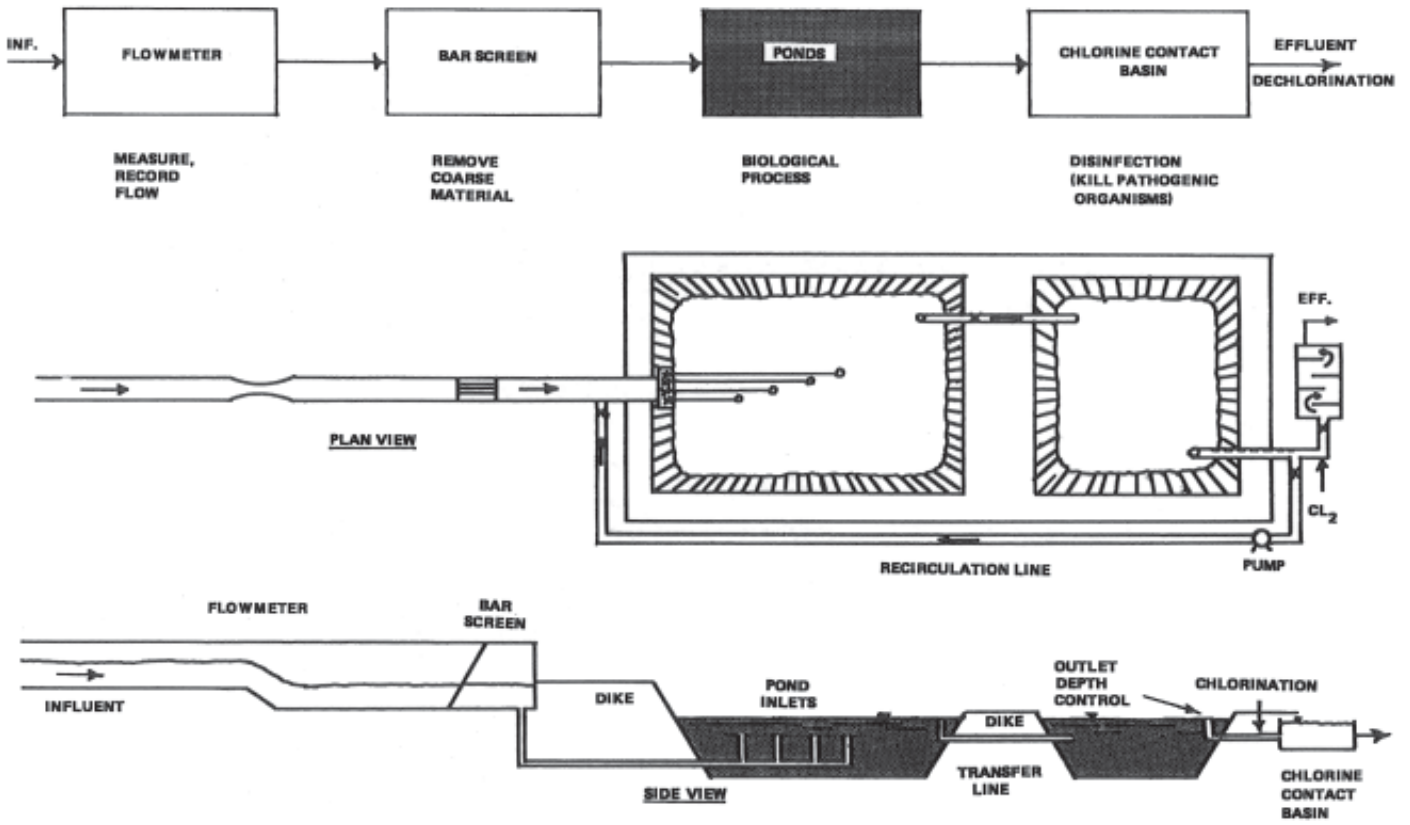
Part	Purpose
Flowmeter	Measures and records flows into pond.
Bar Screen	Removes coarse material from pond influent.
Pond Inlets	Distribute influent in pond.
Pond Depth and Outlet Control	Regulates outflow from pond and depth of water in pond. Allows pond to be drained for cleaning and inspection.
Outlet Baffle	Prevents scum and other surface debris from flowing to next pond or receiving waters.
Dike or Levee	Separates ponds and holds wastewater being treated in ponds.
Transfer Line	Conveys wastewater from one pond to another.
Recirculation Line	Returns pond effluent rich in algae and oxygen from second pond to first pond for seeding, dilution and process control.
Chlorination	Applies chlorine to treated wastewater for disinfection purposes.
Chlorine Contact Basin	Provides contact time for chlorine to disinfect pond effluent.
Effluent Line	Conveys treated wastewater to receiving waters, to point of reuse (irrigation), or to land disposal site.

Reprinted, with permission, from *Operation of Wastewater Treatment Plants*, Vol. I, 2<sup>nd</sup> ed., Office of Water Programs, California State University, Sacramento Foundation

7. Consumes little energy
8. Serves as a wildlife habitat
9. Has an increased potential design life
10. Has few sludge handling and disposal problems
11. Is probably the most trouble-free of any treatment process when used correctly, provided a consistently high quality effluent is not required

The limitations are that a pond:

1. May emit odors
2. Requires a large area of land
3. Treats wastes inconsistently depending on climatic conditions
4. May contaminate ground waters unless properly lined
5. May have high suspended solids levels in the effluent



Reprinted, with permission, from *Operation of Wastewater Treatment Plants*, Vol. I, 4<sup>th</sup> ed., Office of Water Programs, California State University, Sacramento Foundation

Figure 5.1 - Schematics of Typical Pond Layouts

## POND CLASSIFICATIONS AND APPLICATIONS

Ponds are quite commonly used in series (one pond following another) after a primary wastewater treatment plant to provide additional clarification, BOD removal and disinfection. These ponds are sometimes called “oxidation ponds.” Ponds are sometimes used in series after a trickling filter plant, thus giving a form of tertiary treatment. These are sometimes called “polishing ponds.” Ponds placed in series with each other can provide a high quality effluent which is acceptable for discharge into most watercourses. If the detention time is long enough, many ponds can meet fecal coliform standards.

### SERIES OPERATION

Series operation allows the most number of cells to be used in sequence and usually yield the best effluent quality. Series operation is recommended in the summer and fall when the biology is most developed and active.

### PARALLEL OPERATION

Parallel operation is often used in the winter and spring periods in cold climates when treatment efficiency is reduced due to low temperature. Organic overloading and odor production may occur at cold temperature in series operation.

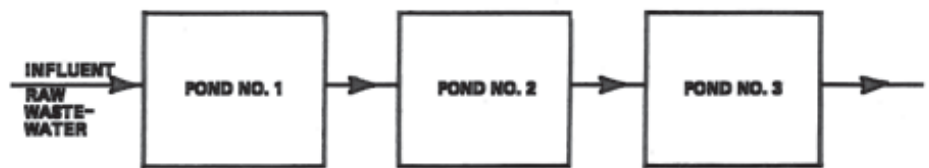
### POND CLASSIFICATION

A great many variations in ponds are possible due to differences in depth, operating conditions, and loadings. A bold line of distinction among different types of ponds is often impossible. Current literature generally uses three broad pond classifications: Aerobic, Anaerobic, and Facultative.

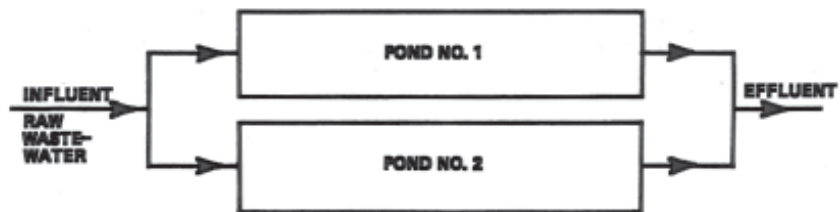
**Aerobic Ponds** are characterized by having dissolved oxygen distributed throughout their contents practically all of the time. They usually require an additional source of oxygen to supplement the rather minimal amount that can be diffused from the atmosphere at the water surface. Aerobic ponds are usually 3-5 feet deep with no aeration. The additional source of oxygen may be supplied by algae during daylight hours.

**Anaerobic Ponds**, as the name implies, usually are without any dissolved oxygen throughout their entire depth. Treatment depends on fermentation of the sludge at the pond bottom. This process can be quite odorous under certain conditions, but it is highly efficient in destroying organic wastes. Anaerobic ponds are mainly used for processing industrial wastes, although some domestic wastes ponds become anaerobic when they are badly overloaded. Anaerobic ponds are >14 feet in depth with an organic loading of 200-1000 lbs BOD<sub>5</sub> per acre per day.

**Facultative Ponds** are the most common type in current use. The name facultative refers to the type of bacteria that can live in both aerobic and anaerobic environments. The upper portion (supernatant) of these ponds is aerobic, while the bottom layer is anaerobic. Algae supply most of the oxygen to the supernatant. Facultative ponds are most common because it is almost impossible to maintain completely aerobic or anaerobic conditions all the time at all depths of the pond. Facultative ponds are 4-8 feet deep



**Stabilization Ponds in Series**



**Stabilization Ponds in Parallel**



**OXIDATION PONDS IN SERIES**



**POLISHING PONDS IN SERIES**

**Figure 5.2 - Pond Types**



with an organic loading of 15-50 lbs BOD<sub>5</sub> per acre per day.

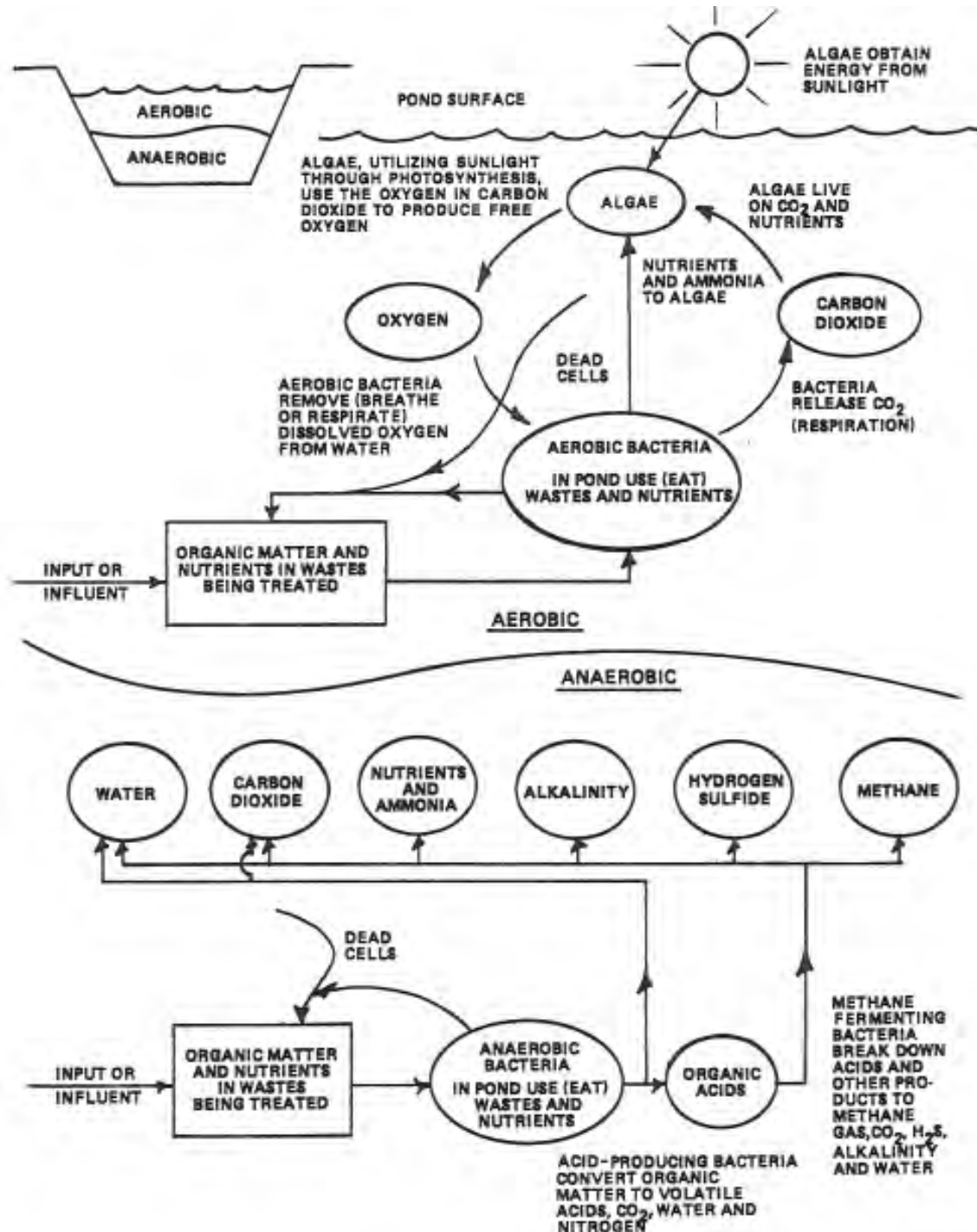
**Tertiary Ponds** or polishing ponds have an organic loading of 5-15 lbs BOD<sub>5</sub> per acre per day.

**EXPLANATION OF TREATMENT PROCESS**

Ponds are classified according to their dissolved oxygen content. Oxygen in an aerobic pond is distributed throughout the entire depth practically all the time. An anaerobic pond is predominantly with oxygen most of the time because

oxygen requirements are much greater than the oxygen supply. In a facultative pond, the upper portion is aerobic most of the time, whereas the bottom layer is predominantly anaerobic.

In aerobic ponds or in the aerobic layer of facultative ponds, organic matter contained in the wastewater is first converted to carbon dioxide and ammonia, and finally to algae in the presence of sunlight. Algae are simple one or many celled microscopic plants which are essential to the successful operation of both aerobic and facultative ponds.



**Figure 5.3 - The Role of Algae in Treating Wastes in a Pond**

Reprinted, with permission, from *Operation of Wastewater Treatment Plants*, Vol. I, 4<sup>th</sup> ed., Office of Water Programs, California State University, Sacramento Foundation

By using sunlight through Photosynthesis the algae use the carbon dioxide in the water to produce free oxygen making it available to the aerobic bacteria that inhabit the pond. Each pound of algae in a healthy pond is capable of producing 1.6 pounds of oxygen on a normal summer day. Algae live on carbon dioxide and other nutrients in the wastewater. At night when light is no longer available for photosynthesis, algae use up the oxygen by respiration and produce carbon dioxide. The alternate use and production of oxygen and carbon dioxide can result in diurnal (daily) variations of both pH and dissolved oxygen. During the day algae uses carbon dioxide which raises the pH while at night they produce carbon dioxide and the pH is lowered. Algae are found in the soil, water and air; they occur naturally in a pond without seeding and multiply greatly under favorable conditions.

In anaerobic ponds or in the anaerobic layer of facultative ponds, the organic matter is first converted by a group of anaerobic organisms to organic acids. In an established pond at the same time, a group called the “methane fermenters” breaks down the acids and other products of the first group to form hydrogen sulfide gas, methane gas, carbon dioxide, and alkalinity. Water is another end product of organic decomposition. This process is described in the figure 5.3.

In a successful facultative pond, the processes characteristic of aerobic ponds occur in the surface layers, while those similar to anaerobic ponds occur in its bottom layers.

During certain periods, sludge decomposition in the anaerobic zone is interrupted and it begins to accumulate. If sludge accumulation occurs and decomposition does not set in, it is probably due to a lack of the right bacteria, low pH, low temperature. Under these circumstances, the acid production will continue at a slower rate, but the rate of gas (methane) production slows down considerably.

Sludge storage in ponds is continuous with small amounts stored during warm weather and larger amounts when it is cold. At colder temperatures, the bacteria cannot multiply fast enough to handle the waste. When warm weather comes, the acid producers begin to decompose the accumulated sludge deposits built up during the winter. If the organic acid production is too great, a lowered pH will occur with the possibilities of an upset pond with resulting hydrogen sulfide odors.

Hydrogen sulfide ordinarily is not a problem in properly designed and operated ponds because it dissociates (divides) into hydrogen and hydrosulfide ions at high pH and may form insoluble metallic sulfides or sulfates. This high

degree of dissociation and the formation of insoluble metallic sulfides are the reasons that ponds having a pH above 8.5 do not emit odors, even when hydrogen sulfide is present in relatively large amounts. An exception occurs in northern climates during the spring when the pH is low and the pond is just getting started; then hydrogen sulfide odors can be a problem.

All of the organic matter that finds its way to the bottom of a stabilization pond through the various processes of sludge decomposition is subject to Methane Fermentation, provided that proper conditions exist or become established. In order for methane fermentation to exist, an abundance of organic matter must be deposited and continually converted to organic acids. An abundant population of methane bacteria must be present. They require a pH level of from 6.5 to 7.5 within the sludge, alkalinity of several hundred mg/l to buffer (neutralize) the organic acids (volatile acid/alkalinity relationship), and suitable temperatures. Once methane fermentation is established, it accounts for a considerable amount of the organic load removal.

#### **POND PERFORMANCE**

The treatment efficiencies that can be expected from ponds vary more than most other treatment devices. Some of the many variables are:

1. Physical Factors
  - a. type of soil
  - b. surface area
  - c. depth
  - d. wind action
  - e. sunlight
  - f. temperature
  - g. short-circuiting
  - h. inflow variations
2. Chemical Factors
  - a. organic material
  - b. pH
  - c. solids
  - d. concentration and nature of waste
3. Biological Factors
  - a. type of bacteria
  - b. type and quantity of algae
  - c. activity of organisms
  - d. nutrient deficiencies
  - e. toxic concentrations

The performance expected from a pond depends largely upon its design. The design, of course, is determined by the waste discharge requirements or the water quality standards to be met in the receiving waters. Overall treatment efficiency may be about the same as primary treatment (only settling of solids), or it may be equivalent

to the best secondary biological treatment plants. Some ponds, usually those located in hot, arid areas, have been designed to take advantage of percolation and high evaporation rate so that there is no discharge.

Depending on design, ponds can be expected to provide BOD removals from 50 to 90 percent. Facultative ponds, under normal design loads with 50 to 60 days detention time, will usually remove approximately 90 to 95 percent of the coliform bacteria and 70 to 80 percent of the BOD load approximately 80 percent of the time. Controlled discharge ponds with 180 day detention times can produce BOD removals from 85 to 95 percent, total suspended solids removals are from 85 to 95 percent, and fecal coliform reductions up to 99 percent.

### **STARTING THE POND**

One of the most critical periods of a pond's life is the time that it is first placed in operation. If at all possible, at least one foot of potable water or treated wastewater should be in the pond before wastes are introduced. During start up the pond's pH should always be kept above 7.5. The water should be turned into the pond in advance to prevent odors developing from wastes solids exposed to the atmosphere. Thus a source of water should be available when starting a pond.

A good practice is to start ponds during the warmer part of the year because a shallow starting depth allows the contents of the pond to cool too rapidly if nights are cold. Generally speaking, the warmer the pond contents the more efficient the treatment process.

Algal Blooms normally will appear from seven to twelve days after wastes are introduced into a pond, but it generally takes at least sixty days to establish a thriving biological community. A definite green color is evidence that a flourishing algae population has been established. After this length of time has elapsed bacterial decomposition of bottom solids will usually become established. This is generally evidenced by bubbles coming to the surface near the pond inlet where most of the sludge deposits occur. Although the bottom is anaerobic, travel of the gas through the aerobic surface layers generally prevents odor release.

Wastes should be discharged to the pond intermittently during the first few weeks with constant monitoring of the pH. The pH in the pond should be kept above 7.5 if possible. Initially the pH of the bottom sludge will be below 7 due to the digestion of the sludge by acid-producing bacteria. If the pH starts to drop, discharge to the pond should be diverted to another pond or diluted with makeup water from another source, if another pond is not available, until the pH recovers. A high pH is essential to encourage a balanced

anaerobic fermentation (bacterial decomposition) of bottom sludge. This high pH also is indicative of high algal activity since removal of the carbonate from the water in algal metabolism tends to keep the pH high. A continuing low pH indicates acid production which will cause odors. Soda ash (sodium carbonate) may be added to the influent in a pond to increase the pH.

### **DAILY OPERATION AND MAINTENANCE**

Because ponds are relatively simple to operate, they are probably neglected more than any other type of wastewater treatment process. Many of the complaints that arise regarding ponds are the result of neglect or poor housekeeping. Following are listed the day-to-day operational and maintenance duties that will help to ensure peak treatment efficiency and to present your plant to its neighbors as a well run waste treatment facility.

#### **SCUM CONTROL**

Scum accumulation is a common characteristic of ponds and is usually greatest in the spring of the year when the water warms and vigorous biological activity resumes. Ordinarily, wind action will dissipate scum accumulations and cause them to settle; however, in the absence of wind or in sheltered areas, other means must be used. If scum is not broken up, it will dry on top and become crusted. Not only is the scum more difficult to break up then, but a species of blue-green algae is apt to become established on the scum. This can give rise to disagreeable odors. If scum is allowed to accumulate, it can reach proportions where it cuts off a significant amount of sunlight from the pond. When this happens the production of oxygen by algae is reduced and odor problems can result.

Many methods of breaking up scum have been used, including agitation with garden rakes from the shore, jets of water from pumps or tank trucks, and the use of outboard motors on boats in large ponds. Scum is broken up most easily if it is attended to promptly.

#### **ODOR CONTROL**

Eventually, odors probably will come from a wastewater treatment plant (we are not making ice cream here) no matter what kind of process is used. Most odors are caused by overloading (see the section on pond loading) or poor housekeeping practices and can be remedied by taking corrective measures. If a pond is overloaded, stop loading and divert influent to other ponds, if available, until the odor problem stops. Then gradually start loading the pond again.

Odors usually occur during the spring warm-up in colder climates because biological activity has been reduced during cold weather. When the water warms, microorganisms

become active, use up all of the available dissolved oxygen, and odors are produced under these anaerobic conditions.

There are several suggested ways to reduce odors in ponds. These include recirculation from aerobic units, and the use of floating aerators. Recirculation from a aerobic pond to the inlet of an anaerobic pond (1 part recycle flow to 6 parts influent flow) will reduce or eliminate odors. Usually, floating aeration equipment is too expensive to have standing idle waiting for an odor problem to develop. Odor masking chemicals also have been promoted for this purpose and have some uses for concentrated sources of specific odors. However, in almost all cases, process control procedures of the type mentioned are preferable. In any event, it is poor process control to wait until an emergency arises to plan for odor control. Try to have possible alternate methods of control ready to go in case they are needed.

### **WEED AND INSECT CONTROL**

Weed control is an essential part of good housekeeping and is not a formidable task with modern equipment. Weeds around the edge are most objectionable because they allow a sheltered area for mosquito breeding and scum accumulation. In most average ponds there is little need for mosquito control when edges are kept free of weed growth. Weeds can also hinder air circulation on a pond. Aquatic weeds, such as cattails, will grow in depths shallower than three feet, so an operating pond level of at least this depth is necessary. Cattails may emerge singly or be well scattered, but should be removed promptly by hand as they will quickly multiply from the root system.

One of the best methods for control of undesirable vegetation is achieved by a daily practice of close inspection and immediate removal of the young plants including roots. Suspended vegetation, such as duckweed, will not flourish if the pond is exposed to a clean sweep of the wind. Dike vegetation control is aided by regular mowing and use of a cover grass that will crowd out undesirable growth. Because emergent weed growth will occur only when sunlight is able to reach the pond bottom, the single best preventive measure against emergent growth is to maintain a water depth of at least three feet. Due to greater water clarity, the amount of sunlight reaching the bottom will be greater in secondary or final ponds than in primary ponds. Because shallow water promotes growth, there will likely always be a battle to keep emergent weeds from becoming well established around lagoon banks.

Whenever emergent or suspended weeds are being pulled from the lagoon, such protective gear as waterproof gloves, boots and goggles should be worn to reduce the chance of infection from pathogens that may be present in the water. Pulled weeds should be buried to prevent odor and insect

problems. Although most stabilization ponds are no deeper than five feet, there is still sufficient depth to drown an person. Using the buddy system and approved flotation devices will greatly increase the safety level when performing any pond maintenance, especially when using a boat or mowing the dike. Control measures include:

### **Emergent Weeds**

1. Keep the water level above three feet.
2. Pull out new (first year) growth by hand
3. Drown the weeds by raising the water level.
4. Lower the water levels, cut the weeds or burn them with a gas burner, and raise the water level (cut and drown).
5. Use herbicides as a last resort (herbicides will also kill the algae in the ponds).

### **Suspended Vegetation**

1. Keep the pond exposed to a clean sweep of the wind.
2. A few ducks may be used to eat light growth of duckweed.
3. Small ponds may be skimmed with rakes or boards. This may have to be repeated.
4. Excessive growth can be mechanically harvested.

### **Dike Vegetation**

1. Mow regularly during the growing season. Dike slopes may be cut using sickle bars or weed-eater equipment. When using heavy equipment, mowers designed especially for cutting slopes are preferable. Any tractor used on the dike should have a low center of gravity. The tractor must be provided with an approved roll-over protective structure and seat belts if within certain use/weight classifications. Check with your local safety regulatory agency for applicable rules.
2. Seed or reseed slopes with desirable grasses that will form a thick and somewhat impenetrable mat.

Herbicides are a last resort in vegetation control for ponds (if then), not only because of the obvious hazards facing the operator, but also because of dangers presented to the biological growth in the pond and receiving stream (if discharging).

**Caution.** Before attempting to apply any insecticide or pesticide, contact your local official in charge of approving pesticide applications. This person can tell you which chemicals may be applied, the conditions of application, and safe procedures.



## **LEEVE MAINTENANCE**

Levee slope erosion caused by wave action or surface runoff from precipitation is probably the most serious maintenance problem. If allowed to continue, it will result in a narrowing of the levee crown which will make accessibility with maintenance equipment most difficult.

If the levee slope is composed of easily eroded material, one long range solution is the use of bank protection such as stone riprap or broken concrete rubble.

Portions of the pond levee or dike not exposed to wave action should be planted with a low growing spreading grass to prevent erosion by surface runoff. Native grasses may naturally seed the levees, or local highway departments may be consulted for suitable grasses to control erosion. If necessary, grass may have to be mowed to prevent it from becoming too high. Do not allow grazing animals to control vegetation because they may damage the levees near the waterline and possibly complicate erosion problems.

Plants or grasses with long roots, such as willows and alfalfa, should not be allowed to grow on levees because they may damage the levees and possibly cause levee failure and costly repair. Burrowing animals such as muskrats, badgers, squirrels and gophers also may cause levees to fail. Remove these animals from levees as soon as possible and repair their burrowed holes immediately.

Levee tops should be crowned so that rainwater will drain over the side in a sheet flow. Otherwise the water may flow a considerable distance along the levee crown and gather enough flow to cause erosion when it finally spills over the side and down the slope.

If seepage or leakage from the ponds appears on the outside of levees, ask your engineer to investigate and solve this problem before further damage occurs to the levee.

## **HEADWORKS AND SCREENING**

Be sure to clean the bar screen as frequently as necessary. The screen should be inspected at least once or twice a day with more frequent visits during storm periods. Screenings should be disposed of daily in a sanitary manner to avoid odors and fly breeding. A method of disposal is to place screenings in garbage cans and request that your local garbage service dispose of the screenings at a sanitary landfill disposal site.

Many pond installations have grit chambers at the headworks to protect raw wastewater lift pumps or prevent plugging of the influent lines. There are many types of grit removal equipment. Grit removed by the various types of mechanical equipment or by manual means will usually contain small

amounts of organic matter and should therefore be disposed of in a sanitary manner.

## **BATCH OPERATION**

Some ponds do not discharge continuously. These ponds may discharge only once (fall) or twice (fall and spring) a year. Advantages to this type of operation are that discharges can be made only when necessary and, if possible, during the nonrecreational season when flows are high in the receiving waters. Discharging when flows are high in the receiving stream, reduce the impact of the effluent on water quality. If your pond is allowed to discharge intermittently (controlled discharge), you must work closely with your pollution control agency and be sure that you are in compliance with the National Pollutant Discharge Elimination System (NPDES) permit. The Operator should test the pond prior to discharge and insure that all water quality parameters will be met.

Ponds should not be emptied too quickly. Usually ponds are emptied in two weeks or less depending on how much water is to be discharged. Normally 1.0 to 1.5 feet of water is left in the bottom of the pond.

## **OPERATING STRATEGY**

In order to prevent your ponds from developing odors or discharging an effluent in violation of the NPDES permit requirements, you should develop a plan to keep your ponds operating as intended.

## **MAINTAIN CONSTANT WATER ELEVATIONS IN THE PONDS**

A constant pond level will help to maintain constant loadings. Should the water surface start to drop, look for the following possible causes:

1. Discharge valve open too far or a stop log is missing
2. Levees leaking due to animal burrows, cracks, soil settlement or erosion
3. Inlet lines plugged or restricted and causing wastewater to back up into the collection system.
4. Should the water surface start to rise, look for:
  - a. Discharge valve closed or lines plugged.
  - b. Sources of infiltration.

Note: Under some conditions you may not want to maintain constant water levels in your ponds. For example, you may allow the water surface to fluctuate to:

- a. Control Shoreline aquatic vegetation,
- b. Control mosquito breeding and burrowing rodents
- c. Handle fluctuating inflows, and
- d. Regulate discharge  
(continuous, intermittent or seasonal).

### DISTRIBUTE INFLOW EQUALLY TO PONDS

All ponds designed to receive the flow should receive the same hydraulic and organic (BOD) loadings.

### KEEP POND LEVEES OR DIKES IN GOOD CONDITION

Proper maintenance of pond levees can be a time saving activity. Regularly inspect levees for leaks and erosion and correct any problems before they become serious. If erosion is a problem at the waterline, install riprap. Do not allow weeds to grow along the waterline and keep weeds on the levee mowed.

### OBSERVE AND TEST POND CONDITION

Daily visual observations can reveal if a pond is treating the wastewater properly. The pond should be a deep green color indicating a healthy algae population. Scum and floating weeds should be removed to allow sunlight to reach the algae in the pond.

Once or twice a week tests should be conducted to determine pond dissolved oxygen level, pH and temperature. It is important that these tests be taken at the same time of the day, as the fluctuating conditions in the pond will change these test results during the day. Keep good records of test results as they will be the prime indicators of a pond's condition. The change in the water quality is the first sign of problems developing in the ponds. Effluent dissolved oxygen should be measured at this time also. Other effluent tests should be conducted at least weekly and include BOD, suspended solids, dissolved solids, coliform group bacteria and chlorine residual. If ponds are operated on a batch or controlled discharge basis, these effluent tests will have to be determined only during periods of discharge.

During warm summer months algae populations tend to be high and may cause high suspended solids concentrations in the effluent. An advantage of ponds in arid regions is that this is also a period of high evaporation rates. Under these conditions effluent flows may drop to almost zero or may be stopped. In the fall and winter when the weather is cool and sunlight is reduced, the algae population in ponds and thus the suspended solids are reduced. This situation could allow ponds to meet effluent requirements during this period.

If test results reveal that certain water quality indicators (such as DO, BOD, pH or suspended solids) are tending to move in the wrong direction, try to identify the cause and take corrective action. Remember that ponds are a biological process and that changes resulting from corrective action may not occur until a week or so after a change has been made.

### TROUBLESHOOTING

The trouble shooting guide on the next pages can provide you with step by step procedures to follow when problems develop in a pond.

### SURFACE AERATORS

Surface aerators have been used in two types of applications:

1. To provide additional air for ponds during the night, during cold weather, or for overloaded ponds;
2. To provide a mechanical aeration device for ponds operated as aerated lagoons. Aerated lagoons operate like activated sludge aeration tanks without returning any settled activated sludge.

In both cases, the aerators are operated by time clocks with established ON/OFF cycles. Laboratory tests on the dissolved oxygen in a pond indicate the time period for ON and OFF cycles to maintain aerobic conditions in the surface layers of the pond. Adjustments in the ON/OFF cycles are necessary when changes occur in the quantity and quality of their influent and seasonal weather conditions. Some experienced operators have correlated their lab test results to pond appearance and regulate the on/off cycles using the following rule: "If the pond has foam on the surface, reduce the operating time of the aerator; and if there is no evidence of foam on the pond surface, increase the operating time of the aerator." If there is a trace of foam on the surface, the operating time is satisfactory.

Surface aerators may be either stationary or floating. Maintenance of surface aerators should be conducted in accordance with manufacturer's recommendations. Always turn off, tag, and lock out electrical current when repairing surface aerators. Special precautions may be necessary to

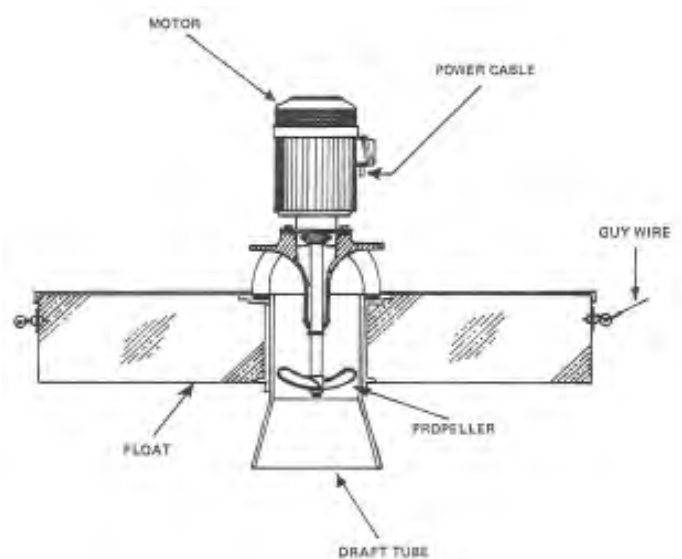


Figure 5.4 - Surface Aerator

Table 5.2a - Troubleshooting Guide — Ponds

(Adapted from *PERFORMANCE EVALUATION AND TROUBLESHOOTING AT MUNICIPAL WASTEWATER TREATMENT FACILITIES*, Office of Water Program Operations, US EPA, Washington, DC.)

INDICATOR/OBSERVATION	PROBABLE CAUSE	CHECK OR MONITOR	SOLUTION
1. Poor quality effluent.	1a. Mixing/agitation equipment failure.	1a. Monitor surface aerators, rotors, or aeration equipment and DO of pond water.	1a. 1. Restart out of service mixing or aeration units. 2. Increase operating time. 3. Increase recycle flow from effluent to influent. 4. Provide additional mixing (small boat and outboard motor for one hour for every two hours of daylight, or at least three times a day).
	1b. Organic overload.	1b. Monitor influent laboratory data: BOD, SS, DO, pH, temperature.	1b. 1. Increase or start recirculation of effluent to influent. 2. Mix pond contents hourly by surface aerators or outboard motor on small boat at least three times per day. 3. Increase run cycle on surface aeration equipment to maintain at least 1.0 mg/L DO. 4. Add chemicals to help reduce pond load by prechlorination for BOD reduction, add sodium nitrate or hydrogen peroxide for oxygen input.
	1c. Excessive turbidity from scum mats.	1c. Floating mats of scum or sludge on surface and corners of pond.	1c. 1. Break up scum mats a. water sprays b. poles or rakes c. mixing equipment d. outboard motor 2. Check pond influent for excess grease or scum. 3. If seasonal temperature change, rising sludge from pond may have to be broken up daily by mixing methods in item 1c.1. above.
	1d. Blockage of light by excessive plant growth (tules, reeds, and/or grasses) near dikes.	1d. Visual inspection for weed growth in and near ponds.	1d. 1. Remove plant growth. 2. Schedule regular herbicide applications to levees and dikes as a last resort.
	1e. Low temperature.	1e. Monitor air and pond water temperature.	1e. 1. Freezing weather, raise pond levels to increase water depth. 2. Reduce recirculation rates. 3. If possible, operate ponds in series.
	1f. Toxic material in influent.	1f. Color change, low DO, low pH for no apparent reason.	1f. 1. Sample and try to identify toxic material. 2. Increase recirculation from effluent to influent. 3. Increase surface aeration or pond mixing times. 4. Implement new or enforce existing sewer-use ordinances. 5. See 1b. above.
	1g. Loss of pond volume caused by sludge accumulation.	1g. Sludge depth.	1g. Remove sludge.

**Table 5.2b - Troubleshooting Guide — Ponds**

INDICATOR/OBSERVATION	PROBABLE CAUSE	CHECK OR MONITOR	SOLUTION
2. Low dissolved oxygen in ponds.	2a. Low algae growth.	2a. Visual inspection, pond not green, low DO during daylight hours, none from sun-up until noon. Odor.	2a. 1. Recirculate last pond effluent to inlet of first pond. 2. Same as 1b.
	2b. Excessive scum accumulation.	2b. Pond surface conditions.	2b. 1. Break up and sink re-suspended scum. 2. Skim off grease balls and scum. Dispose of in landfill.
3. Odors.	3a. Anaerobic conditions.	3a. Monitor pond loading, BOD, SS, pH, DO and temperature.	3a. 1. Limit organic load by diverting influent flows to several ponds. 2. Same as 1b.
	3b. Hydrogen sulfide in pond influent.	3b. Monitor total dissolved H <sub>2</sub> S.	3b. 1. Check collection system. 2. Pretreat with chlorine or pre-aeration. 3. Aerate plant influent in small pond at least 30 minutes before applying to other ponds.
4. Inability to maintain sufficient liquid.	4a. Leakage.	4a. 1. Seepage around dikes. 2. Sampling wells located on the outside perimeter of the pond(s).	4a. 1. Apply bentonite clay to the pond water to seal leak. 2. If sampling well analysis indicates contamination, the lagoon/pond site may require lining.
	4b. Excessive evaporation or percolation.	4b. Detention time in pond is probably too long.	4b. Divert land drainage or stream flow into pond.
5. Insect generation.	5a. Layers of scum and excessive plant growth in sheltered portions of the pond.	5a. Visual inspection. Mosquitoes.	5a. 1. Weed and scum removal. 2. Application of approved insecticides or larvicides.
	5b. Shallow pools of standing water outside pond.	5b. Visual inspection.	5b. Cut vegetation outside pond, and fill in potholes that collect standing water nearby.
6. Levee erosion.	6a. Windy conditions.	6a. Visual inspection.	6a. 1. Riprap levee. 2. Construct a wind barrier around pond.
	6b. Excessive surface aerator operating time.	6b. Aerator operating time.	6b. Reduce aerator operating time if DO levels allow.
7. Excessive weeds and tule growth.	7a. Pond too shallow.	7a. Visual inspection for weeds in the area.	7a. Deepen all pond areas to at least 3 feet.
	7b. Inadequate maintenance program to control vegetation.	7b. Maintenance program.	7b. 1. Correct program deficiency. 2. Install pond lining. 3. Herbicide program as a last resort.
	7c. Poor circulation.	7c. Visual inspection of flow characteristics.	7c. Fluctuate pond level.
8. Animals burrowing into the dikes.	8a. Burrowing animals (gophers, squirrels, crayfish).	8a. Visual inspection.	8a. 1. Alter pond level several times in rapid succession. 2. Remove animals as soon as possible. 3. Provide riprap with semiporous sheet on levee slopes.
9. Groundwater contamination.	9. Leakage through bottom and/or sides of pond.	9. Seepage around pond dikes.	9. Apply bentonite clay to pond water to seal leak.



handle problems with icing and winter maintenance. Overhead guy wires have been used to prevent aerators from turning over when iced up. If an aeration system becomes plugged due to deposits of carbonate, try reducing the aeration or adding carbon dioxide gas.

Mechanical aeration supplements or replaces algal photosynthesis as the source of oxygen for waste stabilization in an aerated lagoon. This increases the cost of operation but decreases the size and cost of the system. The organic loading is higher for aerated lagoons than for facultative lagoons in the range of 50-200 lbs BOD<sub>5</sub> per acre per day. Aeration is provided by brush aerators, propeller pumps, or from a diffused air system. Many aerated lagoons evolve from overloaded facultative lagoons. Properly designed aerated lagoons are 8-16 feet deep, which allows adequate room for sludge storage at the bottom of the lagoon below the influence of mixing. One problem with upgrading a facultative lagoon to an aerated one is the lack of sludge storage capacity in a shallow basin.

**Table 5.3**

**PURPOSE OF AERATOR PARTS**

<b>Part</b>	<b>Purpose</b>
<b>PLATFORM AERATOR COMPONENTS</b>	
<b>Aerator</b>	<b>Introduces oxygen into pond.</b>
<b>Electric Motor</b>	<b>Provides energy to drive aerator.</b>
<b>Drive Reduction Gear Box</b>	<b>Converts torque from motor to drive impeller.</b>
<b>Draft Tube</b>	<b>Conveys bottom contents of pond to surface for aeration.</b>
<b>Discharge Guide</b>	<b>Regulates spray patterns for oxygen transfer to water.</b>
<b>Jacking Screw</b>	<b>Adjusts aerator impeller level in water to regulate oxygen transfer and motor loading amps.</b>
<b>FLOATING AERATOR COMPONENTS (additional)</b>	
<b>Pontoons or Floats</b>	<b>Provide platform for motor.</b>
<b>Guy Wires</b>	<b>Maintain aerator positions in ponds and are anchored to pond levee.</b>
<b>Power Cable</b>	<b>Conveys power to motor.</b>
<b>Impeller (aerator)</b>	<b>Pumps water into air to be aerated.</b>

**SAMPLING AND ANALYSIS**

Probably the most important sampling that can be accomplished easily by any operator is routine pH, temperature, and dissolved oxygen tests several times a week, and occasionally during the night. These values

should be recorded because they will serve as a valuable record of performance. The time of day should be varied occasionally for the tests so that the operator becomes familiar with the pond's characteristics at various times of the day. Usually the pH and dissolved oxygen will be lowest just at sunrise. Both will get progressively higher as the day goes on, reaching their highest level in late afternoon.

Ponds often have clearly developed individuality, each being a biological community that is unique unto itself. Apparently identical adjacent ponds receiving the same influent in the same amount often have a different pH and a different dissolved oxygen content at any given time. One pond may generate considerable scum while its neighbor doesn't have any scum. For this reason, each pond should be given routine pH and dissolved oxygen tests. Such testing may indicate an unequal loading because of the internal clogging of influent or distribution lines that might not be apparent from visual inspection. Tests also may indicate differences or problems that are being created by buildup of solids or solids recycling. PH and D.O. samples are usually collected at the outlet side of the pond unless a complete profile is done. PH and D.O. in primary ponds should be >7.0 pH, and >1.0 mg/l D.O. PH and D.O. in a healthy secondary pond is typically > 8.0 pH and > 5.0 mg/l D.O.

When an operator becomes familiar with operating a pond, the results of some of the chemical tests can be related to visual observations. A deep green sparkling color generally indicates a high pH and a satisfactory dissolved oxygen content. A dull green color or lack of color generally indicates a declining pH and a lowered dissolved oxygen content. A gray color indicates the pond is being overloaded or not working properly.

**FREQUENCY AND LOCATION OF LAB SAMPLES**

The frequency of testing and expected ranges of test results vary considerably from pond to pond, but you should establish those ranges within which your pond functions properly. Tests results will also vary during the hours of the day. The table below summarizes the typical tests, and locations, and frequency of sampling.

Samples should always be collected from the same point or location. Raw wastewater samples for pond influent tests may be collected either at the wet well of the influent pump station or at the inlet control structure. Samples of pond effluent should be collected from the outlet control structure or from a well mixed point in the outfall channel. Pond samples may be taken from the four corners of the pond. The samples should be collected from a point eight feet out from the water's edge and one foot below the water surface. Be careful; try not to stir up material from the

pond bottom. Do not collect pond samples during or immediately after high winds or storms because solids will be stirred up after such activity.

BOD should be measured on a weekly basis. Samples should be taken during the day at low flow, medium flow, and high flow. The average of these three tests will give a reasonable indication of the organic load of the wastewater being treated. If it is suspected that the BOD varies sharply during the day or from day to day, or if unusual circumstances exist, the sampling frequency should be increased to obtain a clear definition of the variations. If the pond DO level is supersaturated, the sample must be aerated to remove the excess oxygen before the BOD test is performed.

**Table 5.4**  
**FREQUENCY AND LOCATION OF**  
**LAB SAMPLES**

Test	Frequency <sup>a</sup>	Location	Common Range
pH <sup>b</sup>	Weekly	Pond	7.5+
Dissolved Oxygen (DO) <sup>b</sup>	Weekly	Pond Effluent	4 - 12 mg/L 4 - 12 mg/L
Temperature	Weekly	Pond	
BOD <sup>c</sup>	Weekly	Influent Effluent	100 - 300 mg/L 20 - 50 mg/L
Colliform-Group Bacteria	Weekly	Effluent	MPN > 24,000/100 mL (unchlorinated)
Chlorine Residual	Daily	Effluent	0.5 - 2.0 mg/L
Suspended Solids <sup>d</sup>	Weekly	Influent Effluent	100 - 350 mg/L 40 - 80 mg/L
Dissolved Solids	Weekly	Influent	250 - 800 mg/L

<sup>a</sup> Tests may be less frequent for ponds with long detention times (greater than 100 days).

<sup>b</sup> pH values above 9.0 and DO levels over 15 mg/L are not uncommon.

<sup>c</sup> Contact your regulatory agency to determine whether effluent samples should be filtered to remove algae before testing. If the samples must be filtered, the agency will recommend the proper procedures.

<sup>d</sup> Effluent suspended solids consist of algae, microorganisms and other suspended matter.

### References

Office of Water Programs, California State University, Sacramento, *Operation of Wastewater Treatment Plants*, Volume 1, 4<sup>th</sup> ed., Chapter 9.

# CHAPTER 6: SEDIMENTATION

## PURPOSE OF SEDIMENTATION AND FLOTATION

Raw or untreated wastewater contains materials which will either settle to the bottom or float to the water surface readily when the wastewater velocity is allowed to become very slow. Collection systems are designed to keep the raw wastewater flowing rapidly to prevent solids from settling out in the collection system lines. Grit channels are designed to allow the wastewater to flow at a slightly slower rate than in the collection system so that heavy, inorganic grit will settle to the bottom where it can be removed. Settling tanks decrease the wastewater velocity far below the velocity in a grit channel.

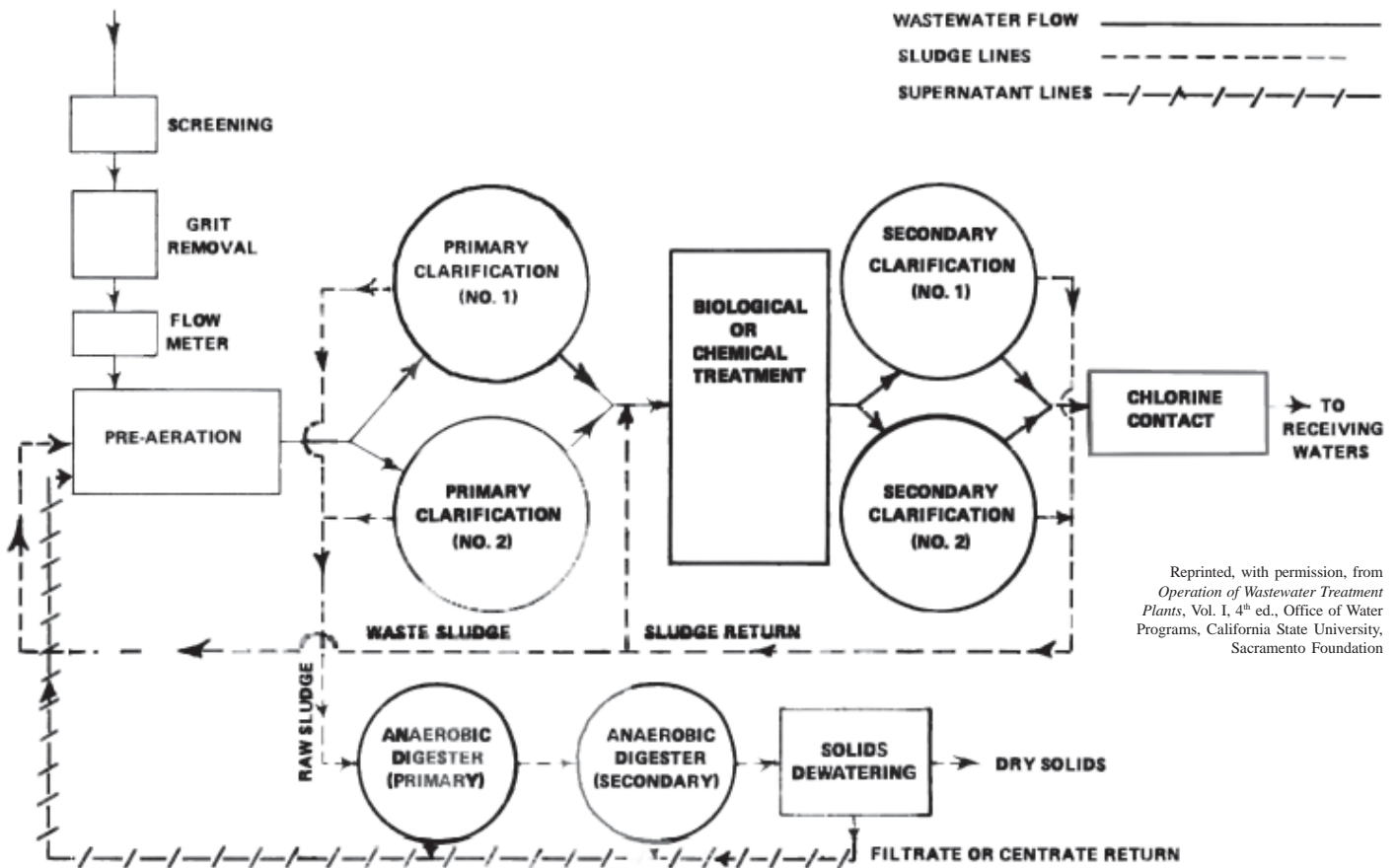
In most municipal wastewater treatment plants, the treatment unit which immediately follows the grit channel is the sedimentation and flotation unit. This unit may be called a settling tank, sedimentation tank, or clarifier. The most common name is primary clarifier, since it helps to clarify or clear up the wastewater.

A typical plant may have clarifiers located at two different points. The one which immediately follows the bar screen, comminutor or grit channel is called the Primary Clarifier,

merely because it is the first clarifier in the plant. The other, which follows other types of treatment units, is called the Secondary Clarifier or the Final Clarifier. The two types of clarifiers operate almost exactly the same way. The reason for having a secondary clarifier is that other types of treatment following the primary clarifier convert more solids to the settleable form, and they have to be removed from the treated wastewater. Because of the need to remove these additional solids, the secondary clarifier is considered part of these other types of processes.

The main difference between primary and secondary clarifiers is in the density of the sludge handled. Primary sludges are usually denser than secondary sludges. Effluent from a secondary clarifier is normally clearer than primary effluent

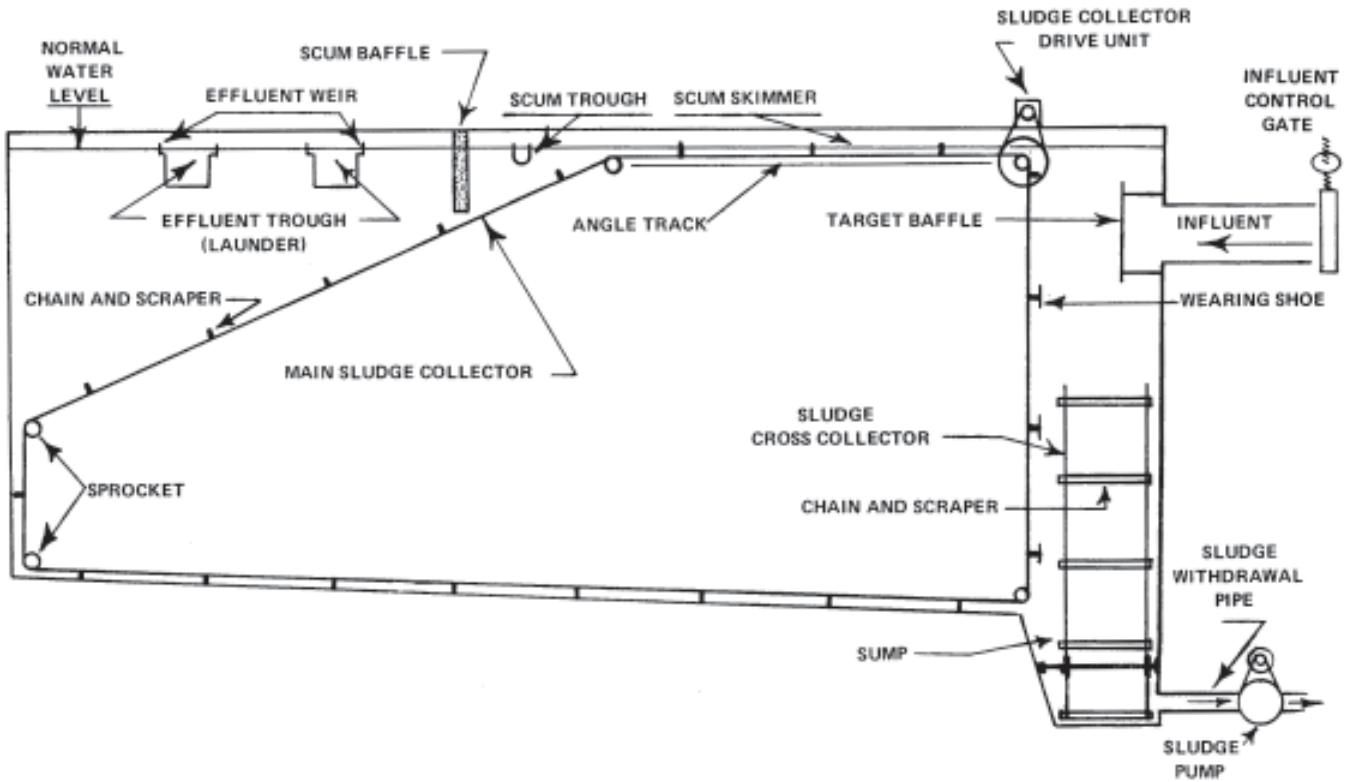
Solids which settle to the bottom of a clarifier are usually scraped to one end (in rectangular Clarifiers) or to the middle (in Circular Clarifiers) into a sump. From the sump the solids are pumped to the sludge handling or sludge disposal system. Sludge handling or sludge disposal system vary from plant to plant and can include sludge digestion, vacuum filtration, incineration, land disposal, lagoons and burial.



Reprinted, with permission, from *Operation of Wastewater Treatment Plants*, Vol. I, 4<sup>th</sup> ed., Office of Water Programs, California State University, Sacramento Foundation

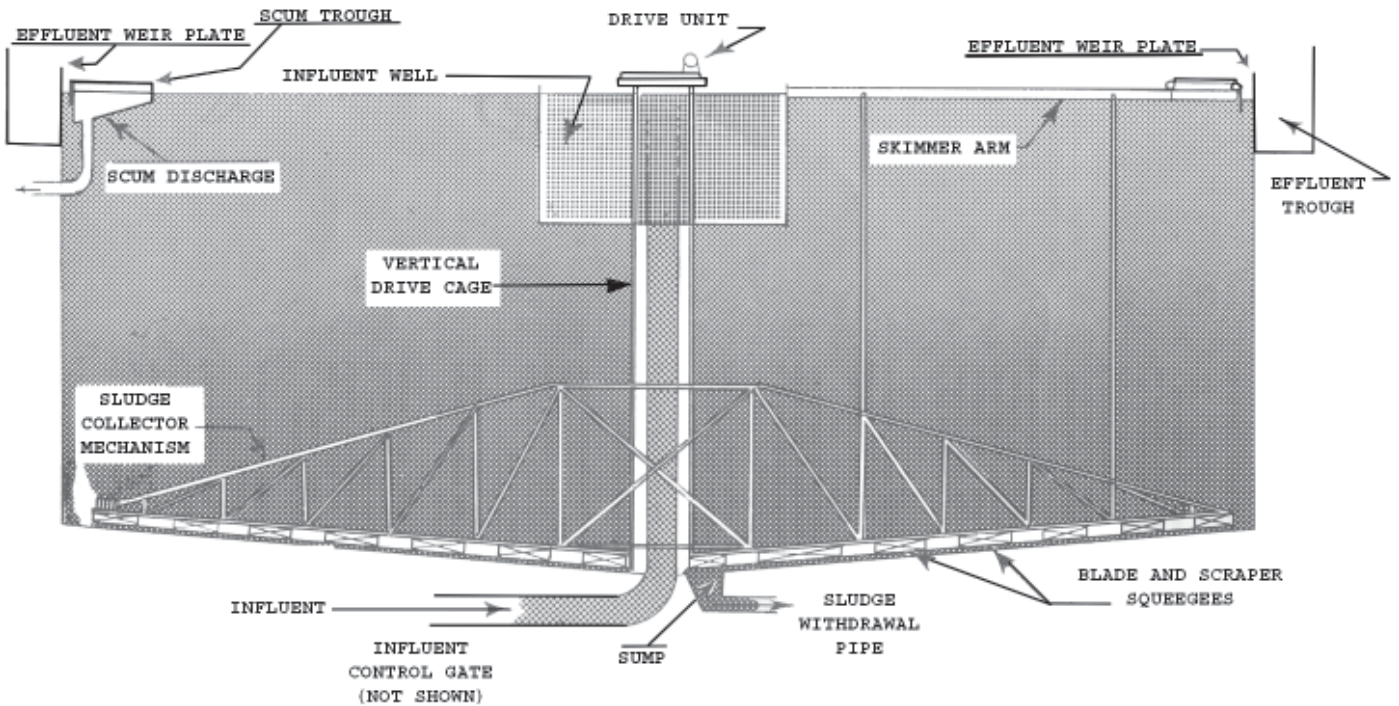
Figure 6.1 - Typical Plant Schematic





**Figure 6.2 - Rectangular Sedimentation Basin**

Reprinted, with permission, from *Operation of Wastewater Treatment Plants*, Vol. I, 4<sup>th</sup> ed., Office of Water Programs, California State University, Sacramento Foundation



**Figure 6.3 - Typical Clarifier**

Reprinted, with permission, from *Operation of Wastewater Treatment Plants*, Vol. I, 4<sup>th</sup> ed., Office of Water Programs, California State University, Sacramento Foundation



**Table 6.1**  
**PURPOSE OF RECTANGULAR SEDIMENTATION BASIN AND PARTS**

Part	Purpose	Part	Purpose
1. Influent Control Gate	Throttles or stops the flow to the sedimentation basin or clarifier.	9. Sludge Withdrawal Pump	Removes the sludge from the sump (pit).
2. Influent Channel or Pipe	Transports wastewater to the clarifier.	10. Scum Skimmer or Collector	Skims or collects floating material from the surface of the wastewater and moves it to the scum trough.
3. Target Baffle or Deflector Plate	Spreads the wastewater evenly across the width of the clarifier for even distribution and prevents short-circuiting.	11. Scum Trough	Receives the floating material from the scum skimmer for removal.
4. Effluent Weir	Insures equal flow over all weirs. Designed for small surface elevation (water level) adjustments in the clarifier provided the plate is designed for vertical movement (up or down).	12. Scum Baffle	Extends above the water surface and prevents the floating material from reaching the effluent trough.
5. Effluent Trough (Launder)	Collects the settled wastewater flowing over the weirs and conveys it from the sedimentation basin.	13. Sludge Collector Drive	Provides power which causes the main and cross collector units to move.
6. Main Sludge Collector	Drags settled solids (sludge) to the sump. A continuous chain with cross pieces (flights or scrapers) attached.	14. Sprocket	Supports chain, adjusts tension or forces the chain to move. A wheel with teeth around the outside that fit in the chain link.
7. Cross Collector	Drags sludge to deep end of sump for removal by pumping. Also prevents bridging of sludge in sump.	15. Wearing Shoe	Prevents wear on the scraper cross pieces. Usually a piece of iron attached close to the outer ends of the scrapers.
8. Sump	Receives settled sludge from the floor of the sedimentation basin. Stores sludge in sufficient quantity to avoid frequent (less than once per hour) removal by pumping, but of sufficient volume to maintain sludge thickness and to exclude water in the sedimentation basin from being pumped out during the pumping cycle.	16. Angle Track	Provides a track on which the main collector cross pieces ride.

Reprinted, with permission, from *Operation of Wastewater Treatment Plants*, Vol. I, 4<sup>th</sup> ed., Office of Water Programs, California State University, Sacramento Foundation

**CALCULATION OF CLARIFIER EFFICIENCY**

To calculate the efficiency of any wastewater treatment process, you need to collect samples of the influent and the effluent of the process, preferably composite samples for a 24- hour period. Next, measure the particular water quality indicators (for example, BOD, suspended solids) you are interested in and calculate the treatment efficiency. Calculations of treatment efficiency are for process control purposes. Your main concern must be the quality of the plant effluent, regardless of percent of wastes removed.

Example:

The influent BOD to a primary clarifier is 200 mg/l, and the effluent BOD is 140 mg/l. What is the efficiency of the primary clarifier in removing BOD?

<u>Known</u>	<u>Unknown</u>
Influent BOD, 200mg/l	Efficiency, %
Effluent BOD, 140 mg/l	

Calculate the BOD removal efficiency:

$$\begin{aligned} \text{Efficiency \%} &= \frac{(\text{In} - \text{Out})}{\text{In}} (100\%) \\ &= \frac{(200\text{mg/l} - 140 \text{mg/l})}{200 \text{mg/l}} (100\%) \\ &= \frac{(60 \text{mg/l})}{200 \text{mg/l}} (100\%) \\ &= (.30)(100\%) \\ &= 30\% \text{ BOD removal} \end{aligned}$$

The same formula is used to calculate clarifier removal efficiency for all the following water quality indicators.

## TYPICAL CLARIFIER EFFICIENCIES

The following is a list of some typical percentages for primary clarifier efficiencies:

<u>Water Quality Indicator</u>	<u>Expected Removal Efficiency</u>
Settleable Solids	95% to 99%
Suspended Solids	40% to 60%
Total Solids	10% to 15%
Biochemical Oxygen Demand (BOD)	20% to 50%
Bacteria	25% to 75%

pH generally will not be affected significantly by a clarifier. You can expect wastewater to have a pH of about 6.5 to 8.0 depending on the region, water supply and wastes discharged into the collection system.

Clarifier efficiencies are affected by many factors, including:

1. Types of solids in the wastewater, especially if there is a significant amount of industrial waste.
2. Age (time in collection system) of wastewater when it reaches the plant. Older wastewater becomes stale or septic; solids do not settle properly because gas bubbles cling on the particles and tend to hold them in suspension.
3. Rate of wastewater flow as compared to design flow. This is called the "hydraulic loading."
4. Mechanical conditions and cleanliness of clarifier.
5. Proper sludge withdrawal. If sludge is allowed to remain in the tank it tends to gasify and the entire sludge blanket (depth) may rise to the water surface in the clarifier.
6. Suspended solids, which are returned to the primary clarifier from other treatment processes, may not settle completely. Sources of these solids include waste activated sludge, digester supernatant and sludge dewatering facilities (centrate from centrifuges and filtrate from filters).

## SLUDGE AND SCUM PUMPING

The particles which settle to the floor of the clarifier are called "sludge." The accumulated sludge should be removed frequently. This is accomplished by mechanical cleaning devices and pumps in most tanks. Mechanically cleaned tanks need not be shut down for cleaning. Septic conditions may develop rapidly in primary clarifiers if sludge is not removed at regular intervals. The proper interval is dependent on many conditions and may vary from thirty minutes to eight hours, and as much as twenty-four hours in a few instances. Experience will dictate the proper frequency of removal. Sludge septicity can be recognized when sludge gasification causes large clumps of sludge to float on the water surface. Septic sludge is generally very odorous and acidic (has a low pH).

**Table 6.2**

<b>PURPOSE OF CIRCULAR CLARIFIER AND PARTS</b>	
<b>Part</b>	<b>Purpose</b>
1. Influent Control Gate	Throttles or stops the flow to the clarifier.
2. Influent Channel or Pipe	Transports wastewater to the clarifier.
3. Influent Well	Receives the flow from the influent pipe, reduces flow velocities and distributes flow evenly across the upper portion of the clarifier contents. A small circular compartment in the top center of the clarifier.
4. Effluent Weir	Insures equal flow over all weirs. Designed for small surface elevation (water level) adjustments in the clarifier, provided the plate is designed for vertical movement (up or down).
5. Effluent Trough (Launder)	Collects the settled wastewater flowing over the weirs and conveys it from the clarifier.
6. Scum Skimmer Arm	Skims or collects floating material from the surface of the wastewater and moves it to the scum trough.
7. Scum Trough	Receives the floating material scraped from the surface by the scum skimming arm.
8. Scum Pipe	Allows the collected scum to flow from the skimmer box to a scum tank or a pump.
9. Drive Unit	Causes the collector to rotate. A power unit which is connected to the vertical drive cage and which causes the collector to rotate.
10. Vertical Drive Cage	Transmits power from drive unit to the sludge collector mechanism.
11. Sludge Collector Mechanism	Drags settled solids across clarifier bottom to a sludge collection pit or sump. A mechanism which rotates around the bottom of the clarifier and consists of squeegee-type scrapers.
12. Blades and Scraper Squeegees	Scrape sludge from bottom of clarifier to sump.
13. Sump	Collects the sludge before withdrawal.
14. Sludge Withdrawal Pipe	Removes the sludge from the clarifier. Usually connected to a sludge pump.

Reprinted, with permission, from *Operation of Wastewater Treatment Plants*, Vol. 1, 4<sup>th</sup> ed., Office of Water Programs, California State University, Sacramento Foundation

As thick a sludge as possible should be pumped from the clarifier sump with the least amount of water. The amount of sludge solids in the water affects the volume of sludge pumped and the digester operation. A good thick primary sludge will contain from 4.0 to 8.0 percent dry solids as indicated by the Total Solids Test in the laboratory. Conditions which may affect sludge concentration are the specific gravity, size and shape of the particles, temperature of wastewater, and turbulence in the tank.

Withdrawal (pumping) rates should be slow in order to prevent pulling too much water with the sludge. While the sludge is being pumped, take samples frequently and examine them visually for excess water. If the samples show a “thin” sludge, it is time to stop pumping.

### **PRIMARY CLARIFIERS**

The most important function of the primary clarifier is to remove as much settleable and floatable material as possible. Removal of organic settleable solids is very important because they cause a high demand for oxygen (BOD) in receiving waters or subsequent biological treatment units in the treatment plant.

While many factors influence the design of clarifiers, settling characteristics of suspended particles in water are probably the most important consideration. Other factors which will influence settling characteristics in a particular clarifier are temperature, short circuits, detention time, weir overflow rate, surface loading rate, and solids loading. These factors are discussed in the following paragraphs.

### **TEMPERATURE**

Water expands as temperature increases (above 4° C) or contracts as temperature decreases (down to 4° C). Below 4° C the opposite is true. In general, as water temperature increases, the settling rate of particles increases; as temperature decreases, so does the settling rate. Molecules of water react to temperature changes. They are closer together when liquid temperature is lower; thus, Density increases and water becomes heavier per given volume because there is more of it in the same space. As water becomes denser, the density difference between water and solids particles becomes less; therefore the particles settle more slowly.

### **SHORT CIRCUITS**

As wastewater enters the settling tank, it should be evenly dispersed across the entire cross section of the tank and should flow at the same velocity in all areas toward the discharge end. When the velocity is greater in some sections than in others, serious short-circuiting may occur. The high velocity area may decrease the detention time in that area, and particles may be held in suspension and pass through

the discharge end of the tank because they do not have time to settle out. On the other hand, if velocity is too low, undesirable septic conditions may occur. Short-circuiting may easily begin at the inlet end of the sedimentation tank. This is usually prevented by the use of weir plates, baffles, port openings, and by proper design of the inlet channel.

### **DETENTION TIME**

Wastewater should remain in the clarifier long enough to allow sufficient settling time for solid particles. If the tank is too small for the quantity of flow and the settling rate of the particles, too many particles will be carried out the effluent of the clarifier. The relationship of detention time to settling rate of the particles is important. Most engineers design settling tanks for about 2.0 to 3.0 hours of detention time. This is, of course, flexible and dependent on many circumstances. Detention time can be calculated by use of two known factors:

1. Flow in gallons per day
2. Tank dimensions or volume

### **WEIR OVERFLOW RATE**

Wastewater leaves the clarifier by flowing over weirs and into effluent troughs (launders) or some type of weir arrangement. The number of lineal feet of weir in relation to the flow is important to prevent short circuits or high velocity near the weir or launder which might pull settling solids into the effluent. The weir overflow rate is the number of gallons of wastewater that flow over one lineal foot of weir per day. Most designers recommend about 10,000 to 20,000 gallons per day per lineal foot of weir. Secondary clarifiers and high effluent quality requirements generally need lower weir overflow rates than would be acceptable for primary clarifiers.

### **SURFACE SETTLING RATE OR SURFACE LOADING RATE**

This rate is expressed in terms of gallons per day per square foot (GPD/sq ft) of tank surface area. Some designers and operators have indicated that the surface loading rate has a direct relationship to the settleable solids removal efficiency in the settling tank. The suggested loading rate varies from 300 to 1,200 GPD/sq ft, depending on the nature of the solids and the treatment requirements. Low loading rates are frequently used in small plants in cold climates. In warm regions, low rates may cause excessive detention which could lead to septicity. The calculation for surface loading rate requires two known factors:

1. flow in GPD/sq ft, and
2. Square feet of liquid surface area

### **SOLIDS LOADING**

The term “solids loading” is used to indicate the amount of solids that can be removed daily by a clarifier for each square foot of clarifier liquid surface area. If the solids



loading increases above design values, you can expect an increase in effluent solids. This concept can be applied to secondary clarifiers and gravity or flotation sludge thickeners. Loading rates are expressed in pounds per day per square foot (lbs/day/sq ft) and depend on the nature of the solids and treatment requirements. To calculate the solids loading requires three known factors:

1. Flow in MGD
2. Suspended Solids concentration in mg/l.
3. Liquid surface area in square feet.

**FOR ADDITIONAL INFORMATION IN CALCULATING SOLIDS LOADING, WEIR OVERFLOWS, SURFACE LOADING RATE IT IS RECOMMENDED YOU READ THE CHAPTER ON SEDIMENTATION IN THE SACRAMENTO MANUAL ON OPERATION OF WASTEWATER TREATMENT PLANTS.**

### **TRICKLING FILTER CLARIFIERS**

A secondary clarifier is used after a trickling filter to settle out sloughings from the filter media. Filter sloughings are a product of biological action in the filter; the material is generally quite high in BOD and will lower the effluent quality unless it is removed. A detailed description of trickling filters will be found in the chapter on Fixed Film Secondary Treatment.

Secondary tanks following trickling filters may be either circular or rectangular and have sludge collector mechanisms similar to primary clarifiers. Clarifier detention times are about the same as for primary clarifiers, but the surface loading and weir overflow rates are generally lower due to the less dense characteristics of secondary sludges. The following are ranges of loading rates for secondary clarifiers used after biological filters:

- Detention time - 2.0 to 3.0 hours
- Surface loading - 800 to 1,200 GPD/sq ft
- Weir overflows - 5,000 to 15,000 GPD/lineal ft

### **ACTIVATED SLUDGE CLARIFIERS**

Secondary clarifier tanks which follow the activated sludge process are designed to handle large volumes of sludge. They are more conservative in design because the sludge tends to be less dense. The following are ranges of loading rates for secondary clarifiers used after aeration tanks in the activated sludge process:

- Detention time - 2.0 to 3.0 hours
- Surface loading - 800 to 1,200 GPD/sq ft
- Weir overflow - 5,000 to 15,000 GPD/lineal ft
- Solids loading - 24 to 30 lbs/day/sq ft

Their purpose is identical, except that the particles to be settled are received from the aeration tank rather than the trickling filter. Most secondary sedimentation tanks used with the activated sludge process are equipped with

mechanisms capable of quickly removing the sludge due to the importance of rapidly returning sludge to the aeration tank. The sludge volume in the secondary tank will be greater from the activated sludge process than from the trickling filter process.

Sludge removal mechanisms in secondary tanks have tended to differ from most primary clarifier mechanisms, especially those in circular clarifiers. These secondary circular clarifiers are designed for continuous sludge removal by Hydrostatic systems, with the activated sludge being pumped back to the aeration tanks by large-capacity pumps. These pumps usually are of the centrifugal type with variable-speed controls or are of the large air-lift type.

Of all the different types of clarifiers that an operator must regulate, secondary clarifiers in the activated sludge process are the most critical and require the most attention from the operator. To help the operator regulate clarifier operation aids have been developed which consist of instrumentation capable of monitoring:

1. Levels of sludge blanket in clarifier
2. Concentration of suspended solids in clarifier effluent
3. Control and pacing of return sludge flows
4. Level of turbidity in clarifier effluent
5. Concentration of dissolved oxygen (DO) in clarifier effluent
6. Level of pH

Laboratory tests should be conducted to measure all of the above items and to provide a check on the accuracy of the instrumentation. Other tests that should be conducted on the clarifier effluent include biochemical oxygen demand (BOD) and ammonia nitrogen (NH<sub>3</sub>-N) measurements.

### **MAINTENANCE**

1. Drive mechanisms contain lubrication points, locations for changing oil in gear boxes (cases), and turntables must be accessible and maintained.
2. Weirs, launders and control boxes must be accessible for cleaning, painting and other maintenance activities.
3. Sludge pumps must be conveniently located and capable of back flushing pipelines or pumping down clarifiers.
4. Provisions should be made for connections and/or locations for portable pumps to dewater clarifiers if clarifiers are not connected to plant drainage systems.
5. Influent and effluent pipelines, conduits or channels must be installed so that each end can be isolated and dewatered by gravity drain or portable pump.



6. Sludge and scum lines to pump suction must be kept as short as possible and free of fittings (90-degree bends and reducers).
7. Cleanouts are required on sludge and scum lines to provide access for cleaning equipment such as sewer rods and high velocity cleaners. Cleanouts should be installed in the lines at locations that allow the lines to be worked on while the clarifier remains in service, instead of having to dewater the clarifier to clear a stoppage or clean a line.
8. Auxiliary service lines (water, air, electrical, instrumentation, sample and chemical feed) should be studied. These lines should have isolation valves (to valve off portions of lines) at appropriate locations and should be accessible for repairs when necessary. Conduits for instrumentation, electrical wiring and cables should be equipped with pull boxes that are watertight. Sample lines should have cleanouts and valving to allow for periodic flushing of the lines. Air lines must be equipped with condensate drains at all low points, including the ends of the line.
9. Covered clarifiers should contain lightweight openings to provide easy access to scum channels, skimmers, launders and drive mechanism units.

#### **SAFETY**

1. Clarifiers must be equipped with adequate access by stairs, ladders, ramps, catwalks and bridges with railings that meet all state and OSHA requirements.
2. Catwalks and bridges must have floor plates or grates firmly secured and equipped with toeboards and nonskid surfaces.
3. Adequate lighting must be provided on the clarifier.
4. Launders, channels and effluent pipelines that carry flow from the clarifier to another conduit, channel or structure must have safety grates over the entrance to prevent accidental entry into the system caused by slipping or falling.
5. In a circular clarifier, turntables, adjustable inlet deflection baffles and return sludge control valves must have safe access without requiring the operator to leave a bridge or catwalk
6. Adequate guards must be placed over chain drives, belts and other moving parts.
7. Safety hooks, poles, and/or floats should be stationed at strategic locations near every basin to rescue anyone who falls into a basin
8. Do not allow any pipes or conduits to cross on top of catwalks or bridges.
9. Adequate offset of drive units, motors, and other equipment must be provided to allow unobstructed access to all areas.

## **COMBINED SEDIMENTATION-DIGESTION UNIT**

### **PURPOSE OF UNIT**

A combined sedimentation-digestion unit consists of a small clarifier constructed over a sludge digester. Treatment units of this type have been designed and constructed to serve small populations such as schools, campgrounds and subdivisions. Usually they are installed instead of Imhoff tanks or septic tank systems. Wastewater treatment efficiencies are similar to primary clarifiers with approximately 65 % of the suspended solids and 35 percent of the biochemical oxygen demand removed from the influent.

### **HOW THE UNIT WORKS**

The combined sedimentation-digestion unit is considered a package treatment plant. Plant influent usually passes through some type of flowmeter to record flows. A bar screen is often the first treatment unit of the package. Coarse solids are caught by the bar screen and removed manually on a daily basis or more often if necessary. Wastewater enters the clarifier near the surface in the center and the circular influent well directs the flow and solids toward the bottom of the clarifier. Settled wastewater slowly flows through the clarifier and leaves over the effluent weir around the outside of the clarifier. The effluent leaves the unit by the effluent trough (launder) and usually receives additional treatment in a secondary package plant such as an activated sludge treatment unit.

Solids settling to the bottom of the clarifier (tray) are scraped to the center of the unit. A slot in the center of the tray allows the solids to flow into the digestion compartment. Below the slot is a sludge seal or boot which prevents gall from digestion and digested sludge from floating up into the clarifier. In the digester, sludge undergoes aerobic decomposition (see sludge digestion). Digested sludge is removed from the bottom of the digester by pumping or by gravity flow to drying beds.

## **IMHOFF TANKS**

### **PURPOSE OF THE UNIT**

The Imhoff tank combines sedimentation and sludge digestion in the same unit. There is a top compartment where sedimentation occurs and a bottom compartment for digestion of settled particles (sludge). The two compartments are separated by a floor with a slot designed to allow settling particles to pass through to the digestion compartment.

### **HOW IT WORKS**

Wastewater flows slowly through the upper tank as in any other standard rectangular or circular sedimentation unit. The settling solids pass through the slot to the bottom sludge

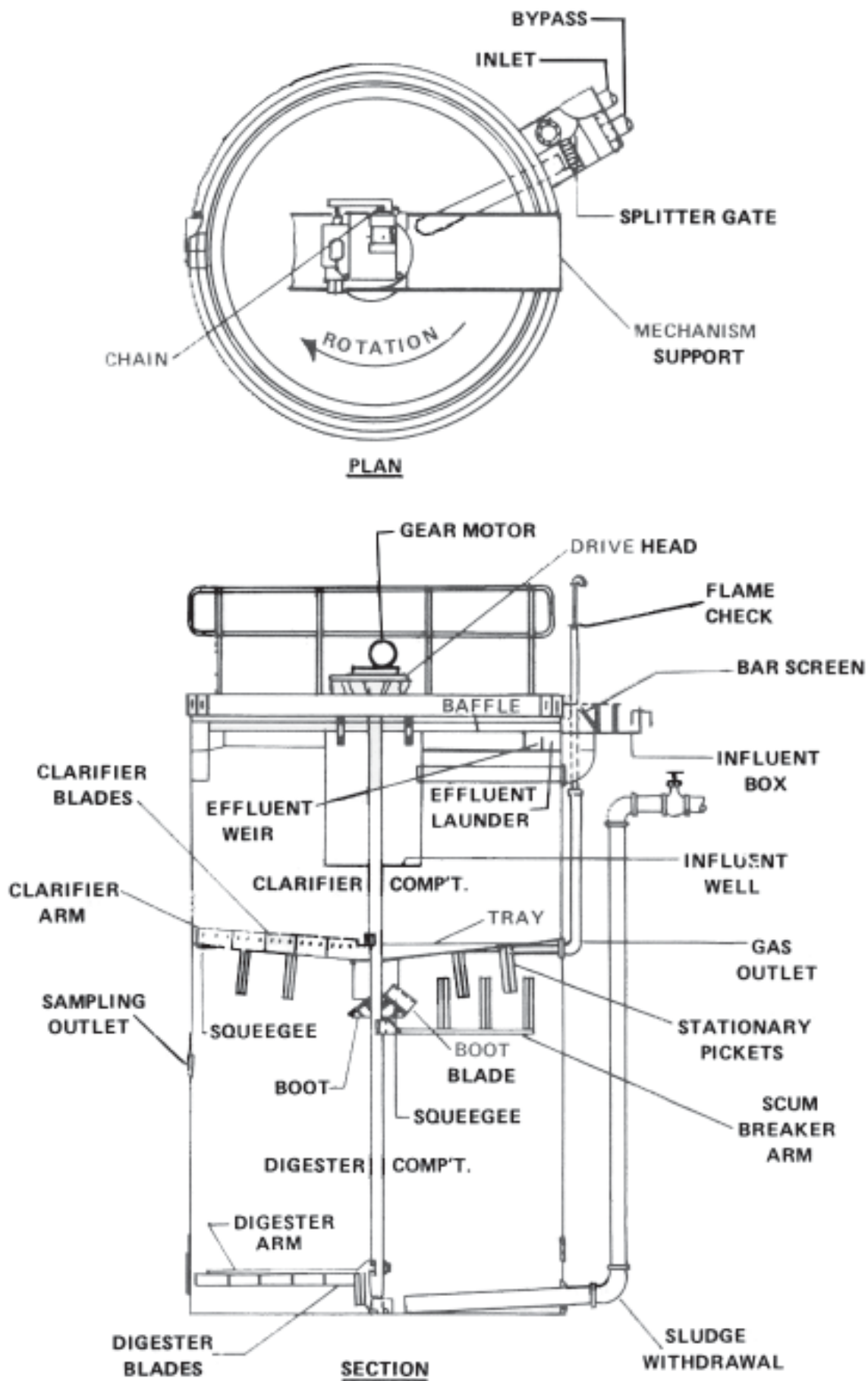


Figure 6.4 - Sedimentation Digestion Unit

digestion tank. Anaerobic digestion of solids is the same as in a separate digester. Gas bubbles are formed in the digestion area by bacteria. As the gas bubbles rise to the surface, they carry solid particles with them. The slot is designed to prevent solids from passing back into the upper sedimentation area as a result of gasification. Solids would flow from the unit with the effluent if they were permitted to pass back into the upper sedimentation area.

The same calculations previously used for clarifiers can be used to determine loading rates for the settling area of the Imhoff tank. Some typical value for design and operation of Imhoff tanks are:

**Settling Area**

- Wastewater detention time - 1.0 to 4.0 hours
- Surface settling rate - 600 to 1,200 GPD/sq ft
- Weir overflow rate - 10,000 to 20,000 GPD/ sq ft
- Suspended solids removal - 45% to 65%
- BOD removal - 25% to 35%

**Digestion Area**

- Digestion capacity - 1.0 to 3.0 cu ft/person
- Sludge storage time - 3 to 12 months

**OPERATIONAL SUGGESTIONS**

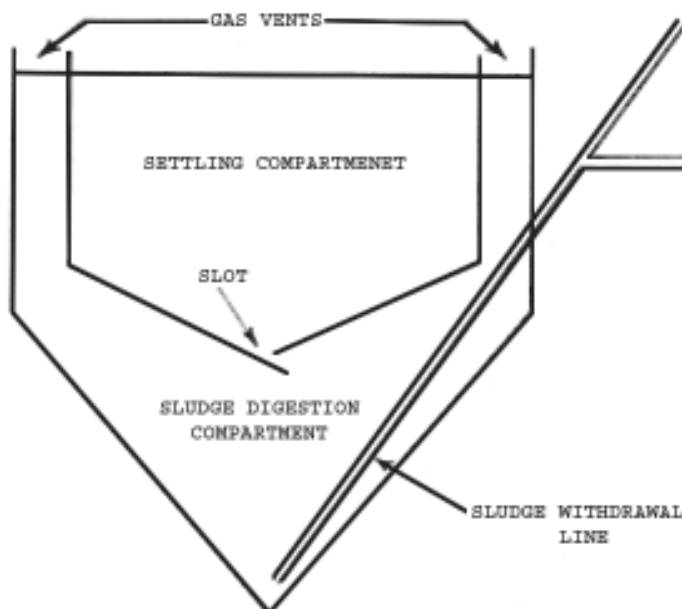
1. In general, there is no mechanical sludge scraping device for removing settled solids from the floor of the settling areas. Solids may accumulate before passing through the slot to the digestion area. It may be necessary to push the accumulation through the slot with a squeegee or similar device attached

to a long pole. Dragging a chain on the floor and allowing it to pass through the slot is another method for removing the sludge accumulation.

2. Scum from the sedimentation area is usually collected with hand tools and placed in a separate container for disposal. Scum also will be transferred to the gas venting area where it will work down into the digestion compartment. Scum in the gas vents should be kept soft and broken up by soaking it periodically with water.

**References**

Office of Water Programs, California State University, Sacramento, *Operation of Wastewater Treatment Plants*, Volume 1, 4<sup>th</sup> ed., Chapter 5.



**Figure 6.5 - Imhoff Tank**

Reprinted, with permission, from *Operation of Wastewater Treatment Plants*, Vol. I, 4<sup>th</sup> ed., Office of Water Programs, California State University, Sacramento Foundation

# CHAPTER 7: FIXED FILM SECONDARY TREATMENT

In order to remove the very small suspended solids (colloids) and dissolved solids, wastewater treatment plants include Secondary Treatment. This process produces an overall plant removal of suspended solids and BOD of 90% or more. The three most common secondary treatment processes are trickling filters, rotating Biological Contactors (RBC) and Activated Sludge. This section will deal with Trickling Filters and RBC's.

## TRICKLING FILTERS

### DESCRIPTION OF A TRICKLING FILTER

Most trickling filters are large diameter, shallow, cylindrical structures filled with stone or plastic media and having an overhead distributor. Many variations of this design have been built. When natural media (stones) are used, the trickling filter is usually cylindrical with a shallow bed;

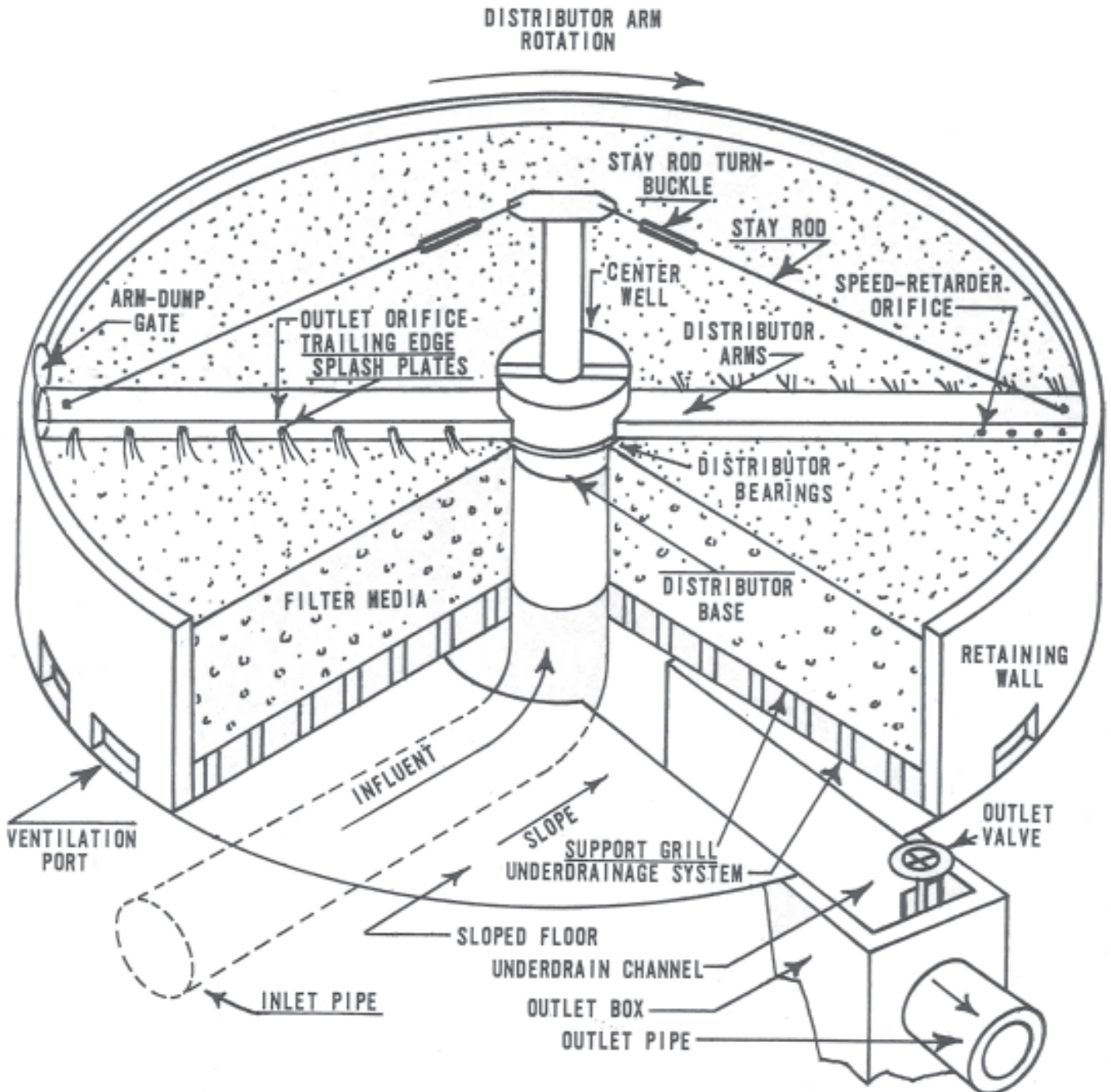


Figure 7.1 -Trickling Filter Crossection

Reprinted, with permission, from *Operation of Wastewater Treatment Plants*, Vol. I, 4<sup>th</sup> ed., Office of Water Programs, California State University, Sacramento Foundation



Table 7.1 – PURPOSE OF TRICKLING FILTER PARTS

Part	Purpose	Part	Purpose
Inlet Pipe	Conveys wastewater to be treated to trickling filter.	Underdrain Channel	Drains filter effluent to outlet box.
Distributor Base	Supports rotating distributor arms.	Outlet Box	Collects filter effluent before it flows to next process.
Distributor Bearings	Allow distributor arms to rotate.	Outlet Valve	Regulates flow of filter effluent from outlet box into outlet pipe. Closed when filter is to be flooded.
Distributor Arm	Conveys wastewater to outlet orifices located along arms.	Outlet Pipe	Conveys filter effluent to next treatment process.
Outlet Orifice	Controls flow to filter media. Adjustable to provide even distribution of wastewater to each square foot of filter media.	Retaining Wall	Holds filter media in place.
Speed-retarder Crifice	Regulates speed of distributor arms.	Ventilation Port	Allows air to flow through media.
Splash Plate	Distributes flow from orifices evenly over filter media.	Stay Rod	Supports distributor arm.
Arm Dump Gate	Drains distributor arm and controls filter flies along filter retaining wall. Also used for flushing distributor arm to remove accumulated debris which might block outlet orifices.	Turnbuckle on Stay Rod	Permits adjusting and leveling of distributor arm in order to produce even distribution of wastewater over the media.
Filter Media	Provide a large surface area upon which the biological slime growth develops.	Center Well	Provides for higher water head to maintain equal flow to distributor arms. Usually a head of 18 to 24 inches (45 to 60 cm) is maintained on the orifices.
Support Grill	Keeps filter media in place and out of underdrain system.	Splitter Box	Divides flow to trickling filters, for recirculation or to secondary clarifiers.
Underdrain System	Collects treated wastewater from under filter media and conveys it to underdrain channel. Also permits air flow through media.	<b>AUXILIARY EQUIPMENT</b>	
		Recirculation Pump	Returns or recirculates flows to trickling filters.

Reprinted, with permission, from *Operation of Wastewater Treatment Plants*, Vol. I, 4<sup>th</sup> ed., Office of Water Programs, California State University, Sacramento Foundation

when synthetic media (plastics) are used, the filter could be cylindrical or rectangular with a much deeper bed. Structures containing deep beds of synthetic media may be called filter towers or biofilter towers.

**PRINCIPLES OF TREATMENT PROCESS**

Trickling filters consist of three basic parts:

1. The media (and retaining structure).
2. The under drain system.
3. The distribution system.

The media provide a large surface area upon which a biological slime growth develops. This slime growth, sometimes called a Zoogloal Film, contains the living organisms that break down the organic material. The media may be rock, slag, coal, bricks, redwood blocks, molded plastic, or any other sound durable material. The media should be of such sizes and stacked in such a fashion as to provide empty spaces (voids) for air to ventilate the filter and keep conditions aerobic. For rock, the size will usually be from about two inches to four inches in diameter. Although actual size is not too critical, it is important that

the media be uniform in size to permit adequate ventilation. The media depth ranges from about three to eight feet for rock media trickling filters and 15 to 30 feet for synthetic media.

The underdrain system of a trickling filter has a sloping bottom. This leads to a center channel which collects the filter effluent. The underdrain systems include the use of spaced redwood stringers or prefabricated blocks constructed of concrete, vitrified clay, or other suitable material.

The distribution system, in the vast majority of cases, is a rotary-type distributor which consists of two or more horizontal pipes supported a few inches above the filter media by a central column. The wastewater is generally gravity fed from the column through the horizontal pipes and is distributed over the media through orifices located along one side of each of these pipes (or arms). Rotation of the arms is due to the rotating water-sprinkler reaction from wastewater flowing out the orifices. The distributors are equipped with mechanical-type seals at the center

column to prevent leakage and protect the bearings. Also attached to the center column are stay rods for seasonal adjustment of the distributor arms to maintain an even distribution of wastewater over the media, and quick opening/arm dump gates at the end of each arm to permit easy flushing.

### **PRINCIPALS OF OPERATION**

The maintenance of a good growth of organisms on the filter media is crucial to successful operation. The term "filter" is rather misleading because it indicates that solids are separated from the liquid by a straining action. This is not the case. Passage of wastewater through the filter causes the development of a gelatinous coating of bacteria, protozoa, and other organisms on the media. This growth of organisms absorbs and uses much of the suspended, colloidal, and dissolved organic matter from the wastewater as it passes over the growth in a rather thin film. Part of this material is used as food for production of new cells, while another portion is oxidized to carbon dioxide and water. Partially decomposed organic matter together with excess and dead film is continuously or periodically washed (sloughed) off and passes from the filter with the effluent.

For the oxidation (decomposition) processes to be carried out, the biological film requires a continuous supply of dissolved oxygen which may be adsorbed from the air circulating through the filter voids (spaces between the rocks or other media). Adequate ventilation of the filter must be provided; therefore the voids in the filter media must be kept open. Ventilation may be by either natural ventilation or by a forced air ventilation system. Clogged void space can create operational problems including ponding and reduction in overall filter efficiency. The void space provided by synthetic (plastic) media is about 95% of the total filter volume, thus providing space for biological slimes to slough and pass through the media. Rock media contains about 35 % void space. Trickling filters with plastic media may be loaded at much higher rates than rock media without developing plugging, ponding, and fly or odor problems. Highly loaded filters may be called roughing filters and are commonly combined with other biological treatment processes to achieve higher levels of BOD removal.

A method of increasing the efficiency of trickling filters is to add recirculation. Recirculation is a process in which filter effluent is recycled and brought into contact with the biological film more than once. Recycling of filter effluent increases the contact time with the biological film and helps to seed the lower portions of the filter with active organisms. Due to the increased flow rate per unit of area, these higher flows tend to cause more continuous and uniform sloughing of excess or aged growths. Sloughing of growths prevents

ponding and improves ventilation through the filter. Increased hydraulic loadings also decrease the opportunity for snail and filter fly breeding. The thickness of the biological growth has been observed to be directly related to the organic strength of the wastewater (the higher the BOD, the thicker the layers of organisms). By the use of recirculation, the strength of wastewater applied to the filter can be diluted, thus helping to prevent excessive buildup of growth.

Recirculation may be constant or intermittent and at a steady or fluctuating rate. Sometimes recirculation (recycling) is practiced only during periods of low flow to keep rotary distributors in motion, to prevent drying of the filter growths, or to prevent freezing. Recirculation in proportion to flow may be used to reduce the strength of the wastewater applied to the filter, while steady recirculation tends to even out the high and lows of organic loading. Steady recirculation, however, requires the use of more energy. Some plants operate intermittently at high recirculation rates (all recirculation pumps on) for two or three hours each week. This high rate will cause sloughing on a regular basis rather than allowing the slime growths to build up and slough under uncontrolled conditions.

### **CLASSIFICATION OF FILTERS**

Depending upon the hydraulic and organic loadings applied, filters are classified as standard-rate, high-rate, or roughing filters. Further designations such as single-stage, two-stage, and series or parallel are used to indicate the flow pattern of the plant. The hydraulic loading applied to a filter is the total volume of liquid, including recirculation, expressed as gallons per day per square foot of filter surface area (GPD/sq ft). The organic loading is expressed as the pounds of BOD applied per day per 1,000 cubic feet of filter media (lbs BOD/day/1,000 cu ft). Where recirculation is used, an additional organic loading will be placed on the filter; however, this added loading is omitted in most calculations because it was included in the influent load.

### **STANDARD-RATE FILTERS**

The standard-rate filter is operated with a hydraulic loading range of 25 to 100 gal/day/sq ft and an organic BOD loading of 5 to 25 lbs/day/1,000 cu ft. The filter media is usually rock with a depth of 6 to 8 feet, with application to the filter by a rotating distributor. Many standard-rate filters are equipped to provide some recirculation during low flow periods.

The filter growth is often heavy and, in addition to the bacteria and protozoa, many types of worms, snails, and insect larvae can be found. The growth usually sloughs off at intervals, noticeably in spring and fall. The effluent

from a standard-rate filter treating municipal wastewater is usually quite stable with BODs as low as 20 to 25 mg/l.

### HIGH-RATE FILTERS

High-rate filters usually have rock or synthetic media with a depth of 3 to 5 feet. Recommended loadings range from 100 to 1,000 gal/day/sq ft for rock and 350 to 2,100 gal/day/sq ft for synthetic media and 25 to 100 lbs BOD/day/1,000 cu ft for rock and 50 to 300 lbs BOD/day/1,000 cu ft for synthetic media. These filters are designed to receive wastewater continually, and practically all high-rate installations use recirculation.

Due to the heavy flow of wastewater over the media, more uniform sloughing of the filter growth occurs from high-rate filters. This sloughed material is somewhat lighter than from a standard-rate unit and therefore more difficult to settle.

### ROUGHING FILTERS

A roughing filter is actually a high-rate filter receiving a very high organic loading. Any filter receiving an organic loading of 100 to over 300 lbs of BOD/day/1,000 cu ft of media volume is considered to be in this class. This type of filter is used primarily to reduce the organic load on subsequent oxidation processes such as a second-stage filter or activated sludge process. Many times they are used in plants which receive strong organic industrial wastes. They are also used where an intermediate (50-70 percent BOD

removal) degree of treatment is satisfactory. Most roughing filters have provisions for recirculation

### FILTER STAGING

Figures 7.2 shows various filter and clarifier layouts. The decision as to the number of filters (or stages) required is one of design rather than operation. In general, however at smaller plants where the flow is fairly low, the strength of the raw wastewater is average and effluent quality requirements are not too strict, a single-stage plant (one filter) is often sufficient and most economical. In slightly overloaded plants, the addition of some recirculation capability can sometimes improve the effluent quality enough to meet receiving water standards and NPDES permit requirements without the necessity of adding more stages.

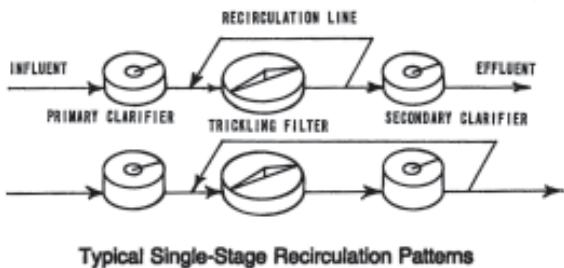
In two-stage filter plants two filters are operated in series. Sometimes a secondary clarifier is installed between the two filters. Recirculation is almost universally practiced at two-stage plants with any different arrangements being possible. The choice of a recirculation scheme is based on consideration of which arrangement produces the best effluent under the particular conditions of wastewater strength and other characteristics.

### OPERATIONAL STRATEGY

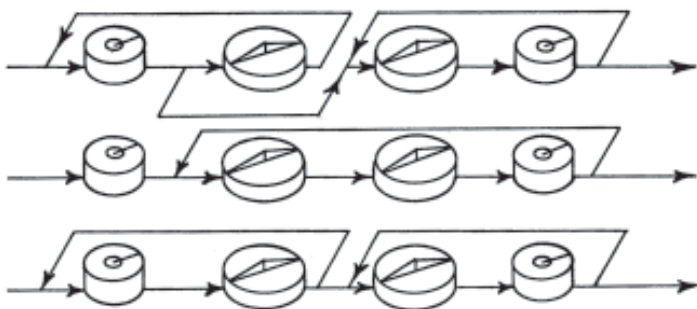
In actual operation, the trickling filter is one of the most trouble-free types of secondary treatment. This process requires less operating attention and control than other types. Where recirculation is used, difficulties due to shock loads are less frequent and recovery is faster. This is because the filter can act like a sponge and treat great amounts of BOD for short time periods without a severe upset. Suspended solids in the trickling filter effluent tend to make the effluent somewhat turbid; thus a poorer quality effluent due to shock loads may not be visibly evident. Recirculation is used to maintain a constant load on the filter and thus produce a better quality of effluent. However, there are some problems which include ponding, odors, insects, and in colder climates, freezing. These problems are all controllable, and in most cases, preventable.

### RESPONSE TO ABNORMAL CONDITIONS

Every wastewater treatment plant will face unusual or abnormal conditions. How successfully these unusual situations are handled depends on the advance planning and preparations taken by the plant operator. Abnormal operating condition in one plant may be handled as a routine procedure in another plant because the operator took the time to review the potential situations and developed a plan to cope with unusual events.



Typical Single-Stage Recirculation Patterns



Typical Two-Stage Recirculation Patterns

Figure 7.2 - Typical Filter and Clarifier Layouts

Reprinted, with permission, from *Operation of Wastewater Treatment Plants*, Vol. 1, 4<sup>th</sup> ed., Office of Water Programs, California State University, Sacramento Foundation



## **PONDING**

Ponding results from a loss of open area in the filter. If the voids are filled, flow tends to collect on the surface in ponds. Ponding can be caused by excessive organic loading without a corresponding high recirculation rate. Perhaps the most common source of ponding is from the lack of good primary clarification prior to the filter. Another cause of ponding can be the use of media which are too small or not sufficiently uniform in size. In nonuniform media, the smaller pieces fit between the larger ones and thus make it easier for the slimes to plug the filter. If this condition exists, replacement of the media is the most satisfactory solution. Other causes of ponding include a poor or improper media permitting cementing or breakup, accumulation of fibers or trash in the filter voids (spaces between media), a high organic growth rate followed by a shock load and rapid uncontrolled sloughing, or an excessive growth of insect larvae or snails which may accumulate in the voids.

The cause of ponding should be identified as it will affect the corrective steps taken to solve the problem. The following are several methods which can be used to solve ponding problems,

1. Spray filter surface with a high pressure water stream.
2. Hand turn or stir the filter surface with a rake, fork, or bar. Remove any accumulation of leaves or other debris.
3. Dose the filter with chlorine at about 5 mg/l for several hours.
4. Flood the filter, keeping the media submerged for 24 hours will cause the growth to slough.
5. Shut off flow to the filter for several hours allowing the growth to dry out.

## **ODORS**

Since operation of trickling filters is an aerobic process, no serious odors should exist unless odor producing compounds are present in the wastewater in high concentrations. The presence of foul odors indicates that anaerobic conditions are predominant. Anaerobic conditions are usually present under that portion of slime growth which is next to the media surface. As long as the surface of the slime growth (Zooglear film) is aerobic, odors should be minor. Corrective measures should be taken immediately if foul odors develop. The following are guidelines for maintaining trickling filters to prevent odor problems.

1. Maintain aerobic conditions in the sewer collection system and in the primary treatment units.
2. Check ventilation in the filter. Heavy biological growths or obstructions in the underdrain system will cut down ventilation.

3. Increase the recirculation rate to provide more oxygen to the filter bed and increase sloughing.
4. Keep the wastewater splash from the distributors in the filter and away from exposed structures, grass, and other surfaces.

## **FILTER FLIES**

The tiny, gnat sized filter fly (*Psychoda*) is the primary nuisance insect connected with trickling filter operations. They are occasionally found in great numbers and can be an extremely difficult problem to plant operating personnel as well as nearby neighbors. Preferring an alternately wet and dry environment for development, the flies are found most frequently in low rate filters and are usually not much of a problem in high rate filters. Control usually can be accomplished by the use of one or more of the following methods.

1. Increase recirculation rate. Synthetic media will require higher hydraulic loadings or the use of weekly flushing by turning on all the filter pumps.
2. Keep orifice openings clear, including end gates of distributor arms.
3. Apply approved insecticides with caution to filter walls and to other plant structures.
4. Flood filter for 24 hours at intervals frequent enough to prevent completion of insect life cycle. This cycle is as short as seven days.
5. Shrubbery, weeds, and tall grass provide a natural sanctuary for filter flies. Good Housekeeping and grounds maintenance will help to minimize fly problems.

## **SLOUGHING**

One of the most common problems with trickling filter operation is the periodic uncontrolled sloughing of biological slime growths from the filter media. Increasing the recirculation pumping rate to the filter on a weekly basis may help to induce controlled sloughing rather than allow the slime growths to build up.

## **POOR EFFLUENT QUALITY**

Check the organic load on the filter when the treated effluent quality is poor. Measure both the soluble and total BOD in the final effluent. The results will indicate if the poor effluent is caused by BOD associated with escaping solids (high total BOD) or whether the poor effluent results from the trickling filter BOD removal capacity being exceeded (high soluble BOD).

## **COLD WEATHER PROBLEMS**

Cold weather usually does not offer much of a problem to wastewater flowing in a pipe or through a clarifier. Occasionally, however, wastewater sprayed from distributor nozzles or exposed in thin layers on the media may reach



the freezing point and cause a buildup of ice on the filter. Several measures can be taken to reduce ice problems on the filter.

1. Decrease the amount of recirculation, provided sufficient flow remains to keep the filter working properly
2. Operate Two Stage Filters in parallel rather than in series.
3. Adjust or remove orifices and splash plates to reduce the spray effect.
4. Construct wind screens, covers, or canopies to reduce heat loss.
5. Physically break up and remove the larger areas of ice buildup.

Although the efficiency of the filter unit is reduced during periods of icing, it is important to keep this unit running. Taking the unit out of service will not only reduce the quality of the effluent but may lead to additional maintenance problems, such as ice forming, with the possibility of structural damage. Also, moisture may condense in the oil and damage the bearings.

## **MAINTENANCE**

### Bearings and Seals

The bearings in distributors may be located in the base of the center column or at the top. Both types will have a water seal at the base to prevent wastewater leakage. This is to avoid uneven distribution of the wastewater over the media, and also to protect the bearings when they are located in the base. Many older distributors used a mercury seal. Mercury should not be used because mercury is toxic to living organisms, including operators.

Generally, the bearings ride on removable races (tracks) in a bath of oil. The oil usually specified is turbine oil with oxidation and corrosion inhibitors added. The manufacturer's literature or the plant O & M manual should specify what type of oil to use.

Be sure to monitor the oil very carefully. The level and condition of the oil are crucial to the life of the equipment, and should be checked weekly. To check, drain out about a pint of oil into a clean container. If the oil is clean and free of water, return it to the unit. If the oil is dirty, drain it and refill with a mixture of approximately ¼ oil and ¾ solvent (such as kerosene), and operate the distributor for a few minutes. Drain again, and refill with the correct oil. (Note; Drawing off some of the oil to check it is important. You can see if the oil is contaminated and verify that the oil level sensing line is not plugged.)

Water in the oil will appear at the bottom of the oil in the container. If water is found in the oil, either the sealing fluid is low or the gasket must be replaced in mechanical seals.

### Distributor Arms

Work on distributor orifices only after the arms have stopped moving. The distributor arms should be flushed weekly by opening the end dump gates one at a time. Also clean debris off of the filter surface each day, cleaning the orifices as often as needed. Observe the distributor daily for smooth operation. If it becomes jumpy, seems to vibrate, or slows down with the same amount of wastewater passing through it, the bearings and races are probably damaged and will require replacement. Adjust the turnbuckles occasionally on the guy rods to keep the rotating distributor arms at the proper level to provide even flow over all of the media.

The speed of rotation of the distributor should not be excessive. Rotation of the distributor is due to the reaction of the water flowing through the orifices. This is similar to the backward thrust of a water hose or the spinning of some types of lawn sprinklers. Speed is controlled by regulation of flow through the orifices. (On larger distributors, approximately 1 RPM is normal.) If the distributor rotates too fast, it may damage the bearing races on the turntable.

To reduce the speed of rotation, provision usually is made on the front of each arm for orifices (see diagram found at the beginning of the chapter). The reaction of the water flowing through these orifices cancels some of the thrust of the regular orifices.

Since most distributors appear rather large and bulky, many operators are surprised to find that they are delicately balanced. As soon as wastewater begins to flow from the orifices, the distributor arm should start to move. The fan like pattern as the wastewater leaves the deflecting plates should be uniform. If the plates have developed a slime growth that is affecting uniform distribution, the slime should be brushed off.

### Underdrains

The underdrains are buried under the filter bed. Usually cleanouts of flusher branches are located on the head end of each line or channel for flushing to remove sludge deposits or debris from the underdrain system. If flushing will not clear the line and your agency or city's collection system maintenance section has a high velocity cleaner for cleaning sewer lines, borrow their services and have them clean the underdrains. You may wish to schedule this cleaning procedure every three to six months in order to keep the underdrain system open and clear.

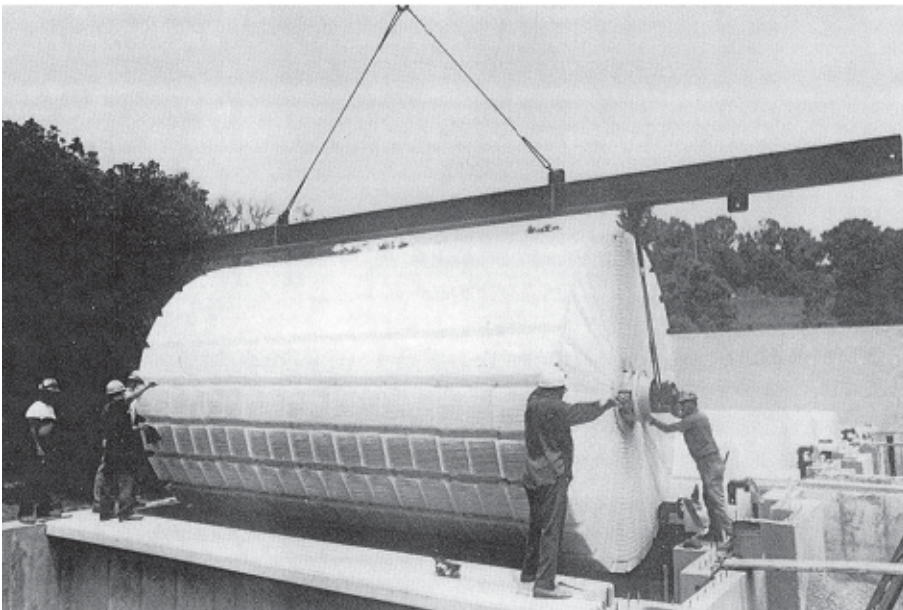
## **SAFETY**

In order to work around a trickling filter safely, several precautions should be taken. **FIRST SHUT OFF THE FLOW TO THE FILTER AND ALLOW THE DISTRIBUTOR TO STOP ROTATING BEFORE ATTEMPTING TO WORK ON IT.** The force of the rotating distributor arms is about the equivalent of a good sized truck. **YOU JUST CAN'T REACH OUT AND STOP ONE WITHOUT ENDANGERING YOURSELF.** Serious injuries can result.

The slime growth on a filter is very slippery. **EXTREME CARE SHOULD BE TAKEN WHEN WALKING ON THE FILTER MEDIA.** Rubber boots with deeply ridged soles will help you keep your footing. Do not carry or use glass containers when working on the media surface.

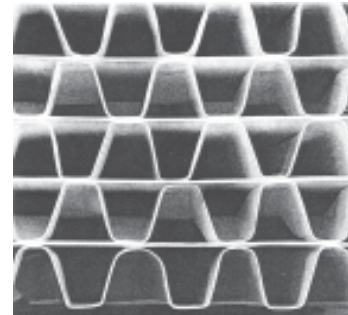
## **ROTATING BIOLOGICAL CONTACTORS**

Rotating biological contactors (RBC's) are a secondary biological treatment process for domestic and biodegradable industrial wastes. Biological contactors have a rotating "shaft" surrounded by plastic discs called the media. The shaft and media are called the drum. A biological slime grows on the media when conditions are suitable. This process is very similar to a trickling filter where the biological slime grows on rock or other media and settled wastewater (primary clarifier effluent) is applied over the media. With rotating biological contactors, the biological slime grows on the surface of the plastic disc media. The slime is rotated into the settled wastewater and then into the atmosphere to provide oxygen for the organisms.

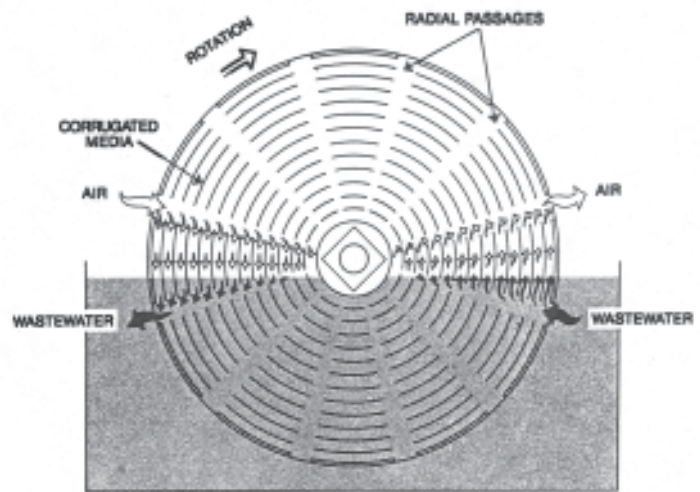


**Figure 7.3 - Rotating Biological Contactor**

The plastic disc media are made of high density plastic circular sheets usually 12 feet in diameter. These sheets are bonded and assembled onto horizontal shafts up to 25 feet in length. Spacing between the sheets provides the hollow (void) space for distribution of wastewater and air.



**Figure 7.4 - Plastic Media Cross Section**



**Figure 7.5**

**End View of RBC Air and Wastewater Exchange**

The rotating biological contactor process uses several plastic media drums. Concrete or coated steel tanks usually hold the wastewater being treated. The media rotate at about 1.5 RPM while approximately 40 percent of the media surface is immersed in the wastewater. As the drum rotates, the media pick up a thin layer of wastewater which flows over the biological slimes on the discs. Organisms living in the slimes use organic matter from the wastewater for food and dissolved oxygen from the air, thus removing wastes from the wastewater. As the attached slimes pass through the wastewater, some of the slimes are sloughed from the media as the media rotates downward into the wastewater being treated. The effluent

with the sloughed slimes flows to the secondary clarifier where the slimes are removed from the effluent by settling.

Figure 7.6 shows the location of a rotating biological contactor process in a wastewater treatment plant. The process is located in the same position as the trickling filter or activated sludge aeration basin. Usually the process operates as a once through system, with no recycling of effluent or sludge, which makes it a simple process to operate.

The major parts of the process are listed in the attached table along with their purposes. The concrete or steel tanks are commonly shaped to conform to the general shape of the media. This shape eliminates dead spots where solids could settle out and cause odors and septic conditions.

The rotating biological contactor process is usually divided into four different stages (see figure next page). Each stage is separated by a removable baffle, concrete wall or cross tank bulkhead. Wastewater flow is either parallel or perpendicular to the shaft. Each bulkhead or baffle has an underwater orifice or hole to permit flow from one stage to the next. Each section of media between bulkheads acts as a separate stage of treatment.

Staging is used in order to maximize the effectiveness of a given amount of media surface area. Organisms on the first stage media are exposed to high levels of BOD and reduce the BOD at a high rate. As the BOD levels decrease from stage to stage, the rate at which the organisms can remove BOD decreases and nitrification starts.

Rotating biological contactors are covered for several reasons relating to climatic conditions:

1. Protect biological slime growths from freezing
2. Prevent intense rains from washing off some of the slime growth
3. Stop exposure of media to direct sunlight to prevent growth of algae
4. Avoid exposure of media to sunlight which may cause the media to become brittle; and
5. Provide protection for operators from sun, rain, snow or wind while maintaining equipment.

Table 7.2- PURPOSE OF PARTS OF A ROTATING BIOLOGICAL CONTACTOR

Part	Purpose
Concrete or Steel Tank Divided into Bays (Sections) by Baffles (Bulkheads)	Tank. Holds the wastewater being treated and allows the wastewater to come in contact with the organisms on the discs.  Bays and baffles. Prevent short-circuiting of wastewater.
Orifice or Weir Located in Baffle	Controls flow from one stage to the next stage or from one bay to the next bay.
Rotating Media	Provide support for organisms. Rotation provides food (from wastewater being treated) and air for organisms.
Cover over Contactor	Protects organisms from severe fluctuations in the weather, especially freezing. Also contains odors.
Drive Assembly	Rotates the media.
Influent Lines with Valves	Influent lines. Transport wastewater to be treated to the rotating biological contactor.  Influent valves. Regulate influent to contactor and also isolate contactor for maintenance.
Effluent Lines with Valves	Effluent lines. Convey treated wastewater from the contactor to the secondary clarifier.  Effluent valves. Regulate effluent from the contactor and also isolate contactor for maintenance.
Underdrains	Allow for removal of solids which may settle out in tank.

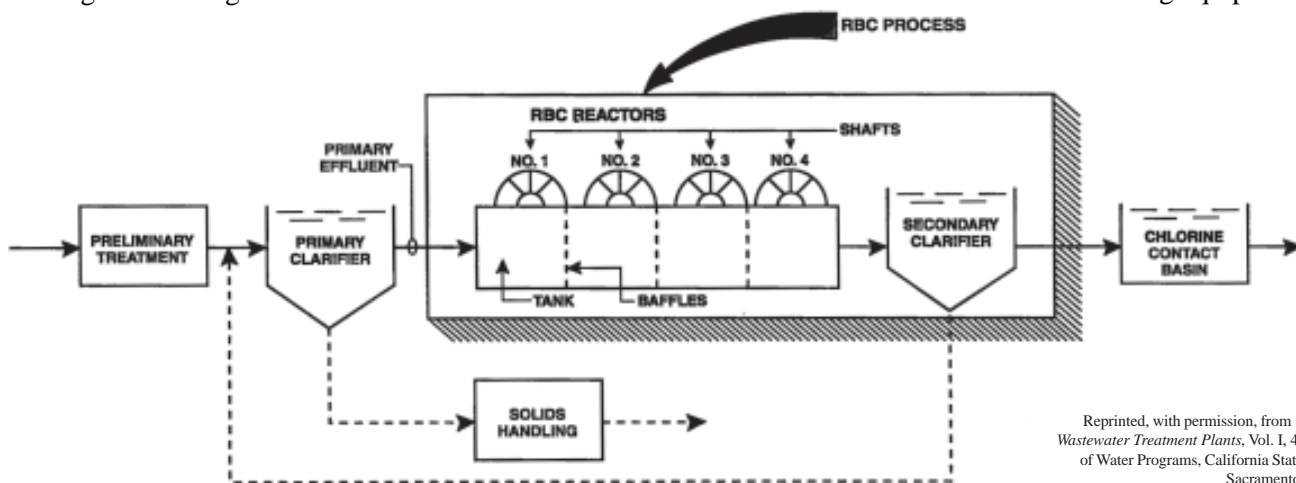
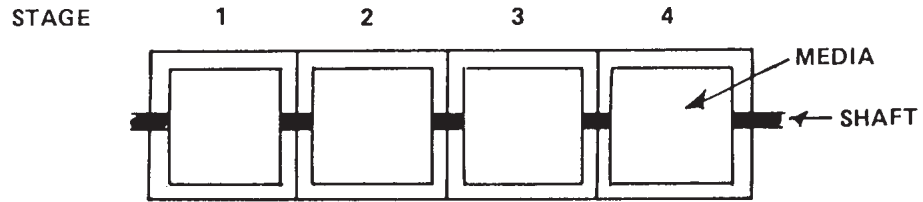
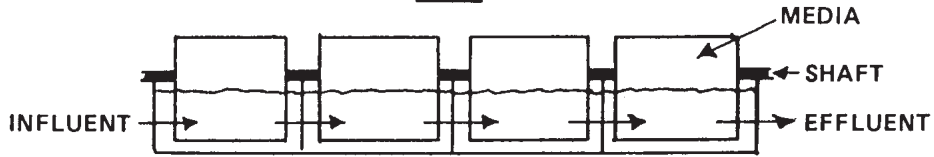


Figure 7.6 - RBC Plant Schematic



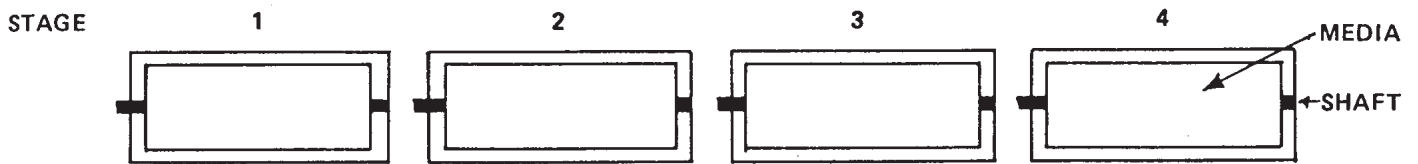


PLAN

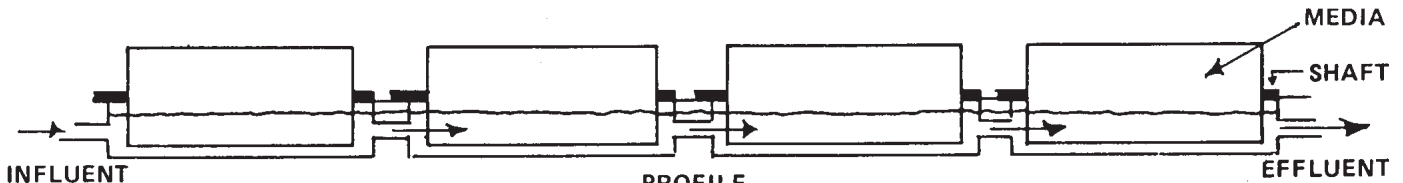


PROFILE

LAYOUT NO. 1 ONE SHAFT, FOUR STAGES  
FLOW PARALLEL TO SHAFT

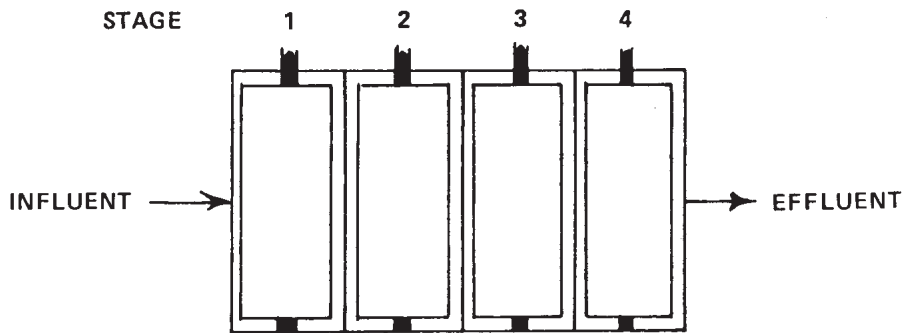


PLAN

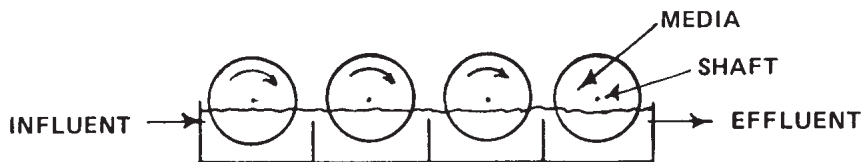


PROFILE

LAYOUT NO. 2 FOUR SHAFTS, FOUR STAGES  
FLOW PARALLEL TO SHAFT



PLAN



PROFILE

LAYOUT NO. 3 FOUR SHAFTS, FOUR STAGES  
FLOW PERPENDICULAR TO SHAFT

**Figure 7.7 - Typical Flow Layouts in RBCs**

Reprinted, with permission, from *Operation of Wastewater Treatment Plants*, Vol. I, 4<sup>th</sup> ed., Office of Water Programs, California State University, Sacramento Foundation



**Table 7.3 – Troubleshooting Guide — Rotating Biological Contactors**

(Adapted from *PERFORMANCE EVALUATION AND TROUBLESHOOTING AT MUNICIPAL WASTEWATER TREATMENT FACILITIES*, Office of Water Program Operations, US EPA, Washington, DC.)

INDICATOR/OBSERVATION	PROBABLE CAUSE	CHECK OR MONITOR	SOLUTION
1. Decreased treatment efficiency.	1a. Organic overload.	1a. Check peak organic loads — BOD, SS, DO, pH, temperature.	1a. 1. Improve pretreatment of plant. 2. Place another RBC in service if available. 3. Remove bulkhead between stages 1 and 2 for larger first stage. 4. Recycle effluent as a possible short-term solution.
	1b. Hydraulic overload.	1b. Check peak hydraulic loads — If less than twice the daily average, should not be the cause.	1b. 1. Flow equalization; eliminate source of excessive flow. 2. Balance flows between reactors. 3. Store peak flows in collection system, monitor possible overflows of collection system.
	1c. pH too high or too low.	1c. Desired range is 6.5 - 8.5 for secondary treatment; 8 - 8.5 for nitrification.	1c. 1. Eliminate source of undesirable pH or add acid or base to adjust pH. When nitrifying, maintain alkalinity at 7 times the influent $NH_3$ concentration. 2. Sodium bicarbonate can be used to increase both pH and alkalinity.
	1d. Low wastewater temperatures.	1d. Temperatures less than 55°F will reduce efficiency.	1d. 1. Cover RBC to contain heat of wastewater. 2. Heat influent to unit or building.
2. Excessive sloughing of biomass from discs.	2a. Toxic materials in influent.	2a. Determine material and its source.	2a. 1. Eliminate toxic material if possible — if not, use flow equalization to reduce variations in concentration so biomass can acclimate. 2. Recycle effluent for dilution.
	2b. Excessive pH variations.	2b. pH below 5 or above 10 can cause sloughing.	2b. Eliminate source of pH variations or maintain control of influent pH.
	2c. Unusual variation in flow and/or organic loading.	2c. Influent flow rate(s) and organic strength.	2c. Eliminate/reduce variations by throttling peak conditions and recycling from the secondary clarifier or RBC effluent during low flows. 2d. Monitor industrial contributors for flow variations.
3. Development of white biomass over most of disc area.	3a. Septic influent or high $H_2S$ concentrations.	3a. Influent odor.	3a. Pre-aerate wastewater or add sodium nitrate or hydrogen peroxide or place another RBC unit in service. Prechlorination of influent will also control sulfur-loving bacteria.
	3b. First stage is overloaded organically.	3b. Organic loading on first stage.	3b. 1. Improve pretreatment of plant. 2. Place another RBC in service, if available. 3. Adjust baffles between first and second stages to increase total surface area in first stage.
4. Solids accumulating in reactors.	4a. Inadequate pretreatment.	4a. Determine if solids are grit or organic.	4a. Remove solids from reactors and provide improved grit removal or primary settling.

Reprinted, with permission, from *Operation of Wastewater Treatment Plants*, Vol. 1, 4<sup>th</sup> ed., Office of Water Programs, California State University, Sacramento Foundation

## **OBSERVING THE MEDIA**

Rotating biological contactors use bacteria and other living organisms growing on the media to treat waste. Because of this, you can use your senses of sight and smell to identify problems. The slime growth or biomass should have a brown to gray color, no algae present, a shaggy appearance with a fairly uniform coverage, and very few or no bare spots. The odor should not be offensive, and certainly there should be no sulfide (rotten egg) smells.

## **BLACK APPEARANCE**

If the appearance becomes black and odors which are not normal do occur, then this could be an indication of solids or BOD overloading. These conditions would probably be accompanied by low DO in the plant effluent. Compare previous influent suspended solids and BOD values with current test results to determine if there is an increase. To solve this problem, place another rotating biological contactor unit in service, if possible, or try to pre-aerate the influent to the RBC unit. Also review the operation of the primary clarifiers and sludge digesters to be sure they are not the source of the overload.

## **WHITE APPEARANCE**

A white appearance on the disc surface also might be present during high loading conditions. This might be due to a type of bacteria which feeds on sulfur compounds. The overloading could result from industrial discharges containing sulfur compounds upon which certain sulfur loving bacteria thrive and produce a white slime biomass. Corrective action consists of placing another RBC unit in service or trying to pre-aerate the influent to the unit. During periods of severe organic or sulfur overloading, remove the bulkhead or baffle between stages one and two.

Another cause of overloading may be sludge deposits that have been allowed to accumulate in the bottom of the bays. To remove these deposits, drain the bays, wash the sludge deposits out and return the unit to service. Be sure the orifices in the baffles between the bays are clear.

## **SLOUGHING**

If severe sloughing or low growth of biomass occurs after the start-up period and process difficulty arises, the causes may be due to the influent wastewater containing toxic or inhibitory substances that kill the organisms in the biomass or restrict their ability to treat wastes. To solve this problem, steps must be taken to eliminate the toxic substance even though this may be very difficult and costly. Biological processes will never operate properly as long as they attempt to treat toxic wastes. Until the toxic substance can be located and eliminated, loading peaks should be dampened (reduced) and a diluted uniform concentration

of the toxic substance allowed to reach the media in order to minimize harm to the biological culture.

Another problem which could cause low growth of biomass is an unusual variation in flow and/or organic loading. In small communities one cause may be high flow during the day and near zero flow at night. During the day the biomass is receiving food and oxygen and starts growing; then the night flow drops to near zero, available food is reduced and nearly stops. The biomass starts sloughing off again due to lack of food.

## **MAINTENANCE**

Rotating biological contactors have few moving parts and require minor amounts of preventive maintenance. Chain drives, belt drives, sprockets, rotating shafts and any other moving parts should be inspected and maintained in accordance with manufactures instructions or your plants O & M manual. All exposed parts, bearing housing, shaft ends and bolts should be painted or covered with a layer of grease to prevent rust damage. Motors, speed reducers and all other metal parts should be painted for protection.

## **References**

Office of Water Programs, California State University, Sacramento, *Operation of Wastewater Treatment Plants*, Volume 1, 4<sup>th</sup> ed., Chapters 6, & 7

## CHAPTER 8: MECHANICAL SYSTEMS

Pumps serve many purposes in wastewater collection systems and treatment plants. They are classified by the character of the material handled; raw wastewater, grit, effluent, activated sludge, raw sludge, or digested sludge. Or, they may relate to the conditions of pumping: high lift, low lift, recirculation, or high capacity. They may be further classified by principle of operation, such as centrifugal, propeller, reciprocating and turbine. The operation and maintenance of these pumps are some of the most important duties for many wastewater utility operators. The two most common type of pump are the centrifugal pump and the positive displacement pump.

Pumps are rated by the flow they produce and the pressure they must work against. Centrifugal pumps are used for high flow and low head pressure applications. Booster pumps or primary service pumps are required to move high volumes of water and usually operated at low head pressures (200-300 feet of head for water and as little as 50 feet of head for wastewater applications). Centrifugal pumps are ideally suited to these types of applications and are much more efficient than positive displacement pumps of comparable size. Positive displacement pumps are used for low flow and high-pressure applications. High pressure water jet systems like those used for well screen or sewer line cleaning use positive displacement pumps since pressure in excess of 2500 feet of head are needed and the flows seldom exceed 100 gpm. Sludge pumps and chemical feed pumps are also likely to be positive displacement pumps. Piston pumps, diaphragm pumps, and progressive cavity screw pumps are the most common types of positive displacement pumps.

Another difference between centrifugal and positive displacement pumps has to do with how they react to changes in discharge pressure. When the pressure that a centrifugal pump has to work against changes, the flow from the pump changes. As the pressure increases, the flow from the pump will decrease, and when the pressure drops the flow will increase. Positive displacement pumps do not react this way. The flow does not change when the discharge pressure changes. This is the main reason that positive displacement pumps are used for chemical feeding and sludge pumping. The operator knows that every time the pump strokes, it is pumping the same amount of fluid. This is important if accurate records are to be kept of chemical dosages and pounds of solids that are moving through the system.

### CENTRIFUGAL PUMPS

A centrifugal pump moves water by the use of centrifugal force. Any time an object moves in a circular motion there is a force exerted against the object in the direction opposite the center of the circle. This would be easier to explain if we use an example consisting of a person with a bucket full of water. If the person swings the bucket in a circle fast enough, the water will stay in the bucket even when it is upside down. The force that holds the water in the bucket is called centrifugal force. If a hole is made in the bottom of the bucket, and it is swung in a circular motion, the centrifugal force will push the water out of the bucket through the hole. The same principle applies when water is moved through a centrifugal pump.

An impeller spins inside a centrifugal pump. It is the heart of the pump. Water enters the center, or suction eye, of the impeller. As the impeller rotates, the veins pick up the water and sling it out into the pump body under pressure. It is the pressure exerted by the vanes that moves the water out of the pump and into the system. The suction created as the water leaves the impeller draws more water into the impeller through the suction eye.

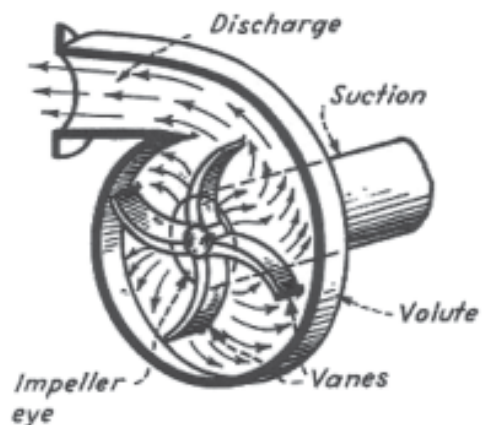


Figure 8.1 - Centrifugal Pump Crosssection

### IMPELLER ROTATION AND CENTRIFUGAL FORCE

The number of vanes and the sweep of the veins determine the performance characteristics of the impeller. As vanes are added, the impeller will produce higher discharge pressures and lower flows. The same situation applies to increasing the length or sweep of the vanes. Reducing the number of vanes or the sweep of the vanes will increase the flow and reduce the pressure.

Table 8.1 - Pump Characteristics

TYPE OF PUMP	PRESSURE/FLOW RATING	CHARACTERISTICS
Centrifugal	Low Pressure/High Flow	Flow changes when pressure changes
Positive-Displacement	High Pressure/Low Flow	Flow doesn't change when pressure changes

## CENTRIFUGAL PUMPS

Centrifugal pumps designed for pumping wastewater usually have smooth channels and impellers with large openings to prevent clogging.

Impellers may be of the open or closed type. Submersible pumps usually have open impellers and are frequently used to pump wastewater from wet wells in lift stations.

## PROPELLER PUMPS

There are two basic types of propeller pumps, axial-flow and mixed-flow impellers. The axial-flow propeller pump is one having a flow parallel to the axis of the impeller. The mixed-flow propeller pump is one having a flow that is both axial and radial to the impeller.

## VERTICAL WET WELL PUMPS

A vertical wet well pump is a vertical shaft, diffuser type centrifugal pump with the pumping element suspended from the discharge piping. The needs of a given installation determine the length of discharge column. The pumping bowl assembly may connect directly to the discharge head for shallow sumps, or may be suspended several hundred feet for raising water from wells. Vertical turbine centrifugal pump consists of multiple impellers that are staged on a vertical shaft. The impellers are designed to bring water in the bottom and discharge it out the top. This results in axial flow as water is discharged up through the column pipe. Staging the impellers in these pumps can create very high discharge pressures, since the pressure increases as the water moves through each stage.

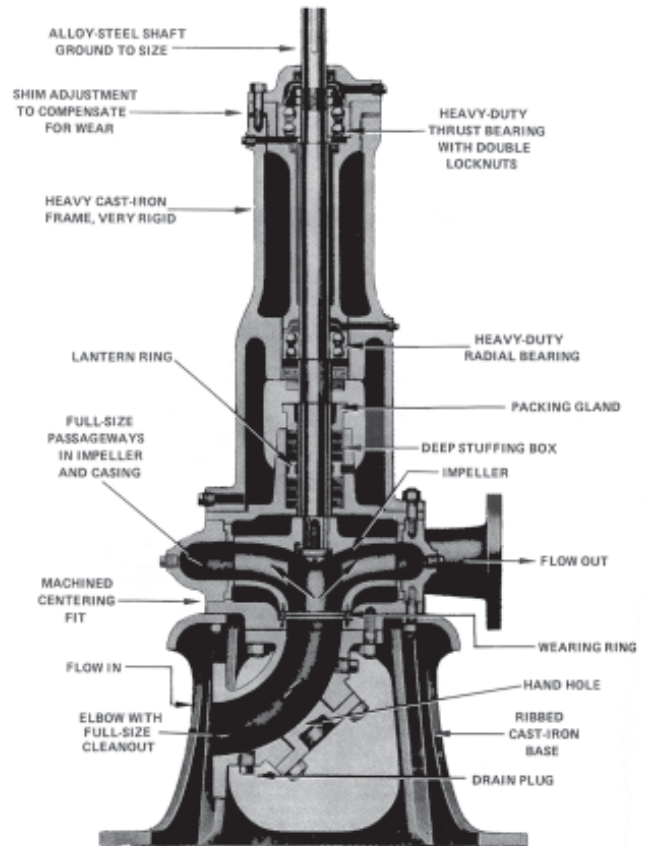


Figure 8.3

*Vertical Ball Bearing Type Wastewater Pump*

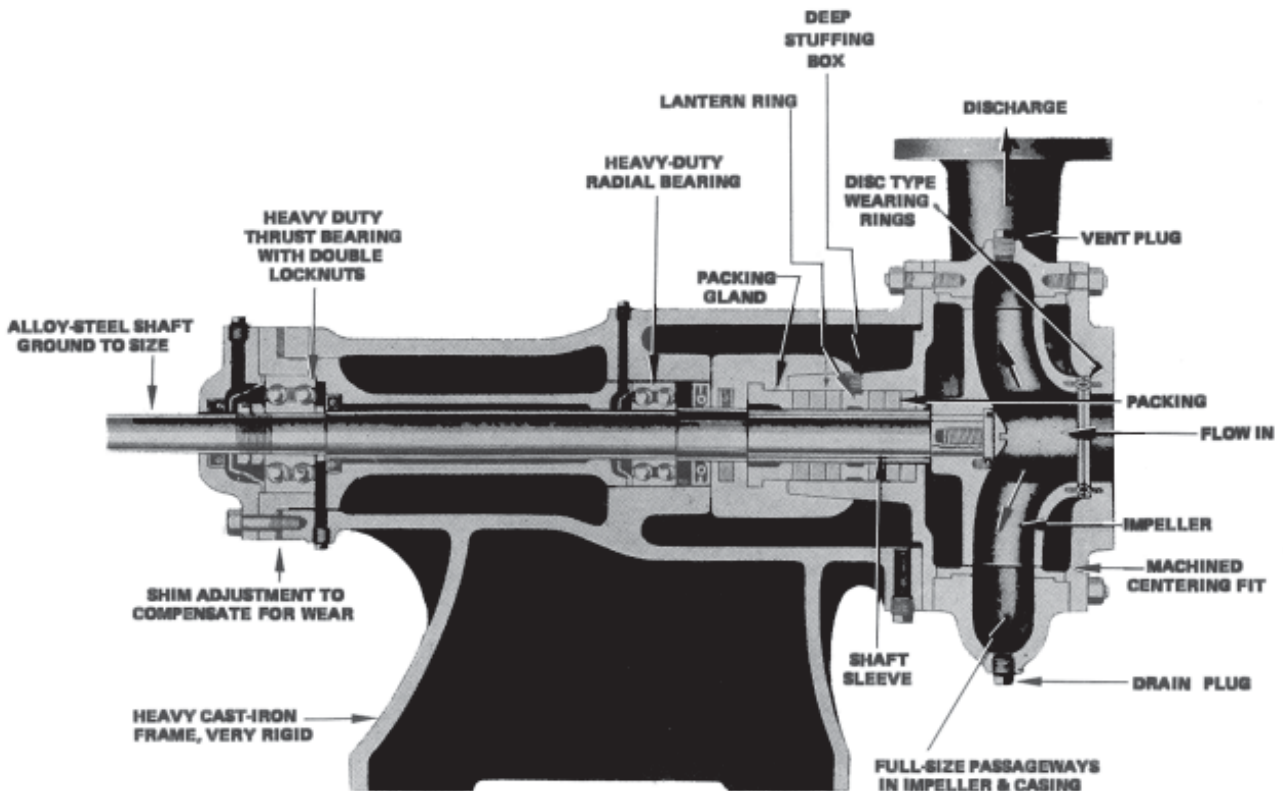


Figure 8.2 - *Horizontal Nonclog Wastewater Pump with Open Impeller*



1. LIFTING HANDLE
2. JUNCTION CHAMBER WITH WATERTIGHT CABLE ENTRIES
3. ANTIFRICTION BEARINGS
4. SHAFT
5. STATOR WITH TEMPERATURE SENSING THERMISTORS
6. ROTOR
7. STATOR HOUSING LEAKAGE SENSOR
8. BEARING TEMPERATURE THERMISTOR
9. SHAFT SEAL
10. OIL CHAMBER
11. VOLUTE
12. NONCLOG IMPELLER
13. COOLING JACKET
14. SLIDING BRACKET
15. AUTOMATIC DISCHARGE CONNECTION

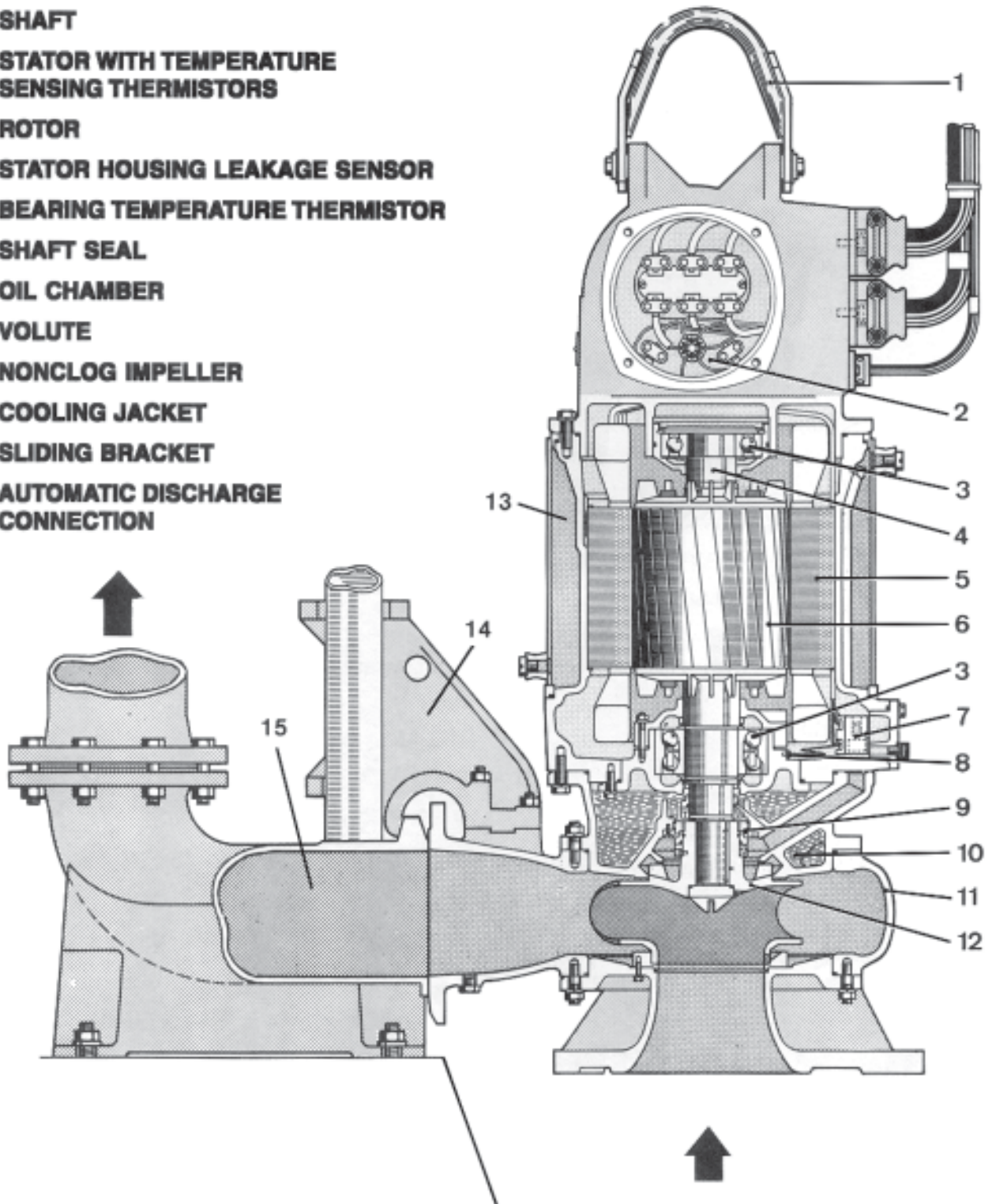
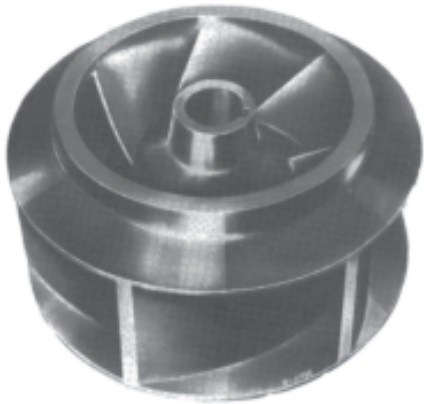
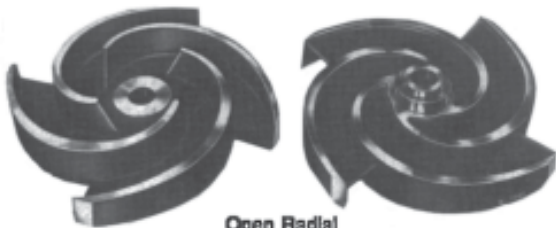


Figure 8.4 - Submersible Wastewater Pump



**Closed Radial**  
 (Closed radial impellers are used in wastewater treatment plants.)

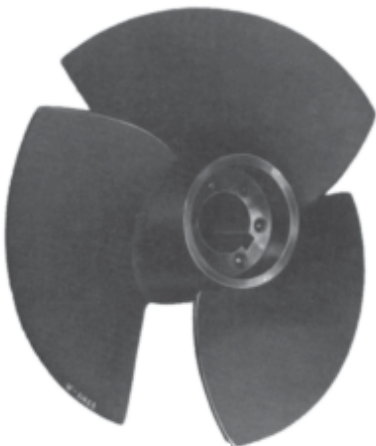


**Open Radial**

**Figure 8.5 - Impellers**

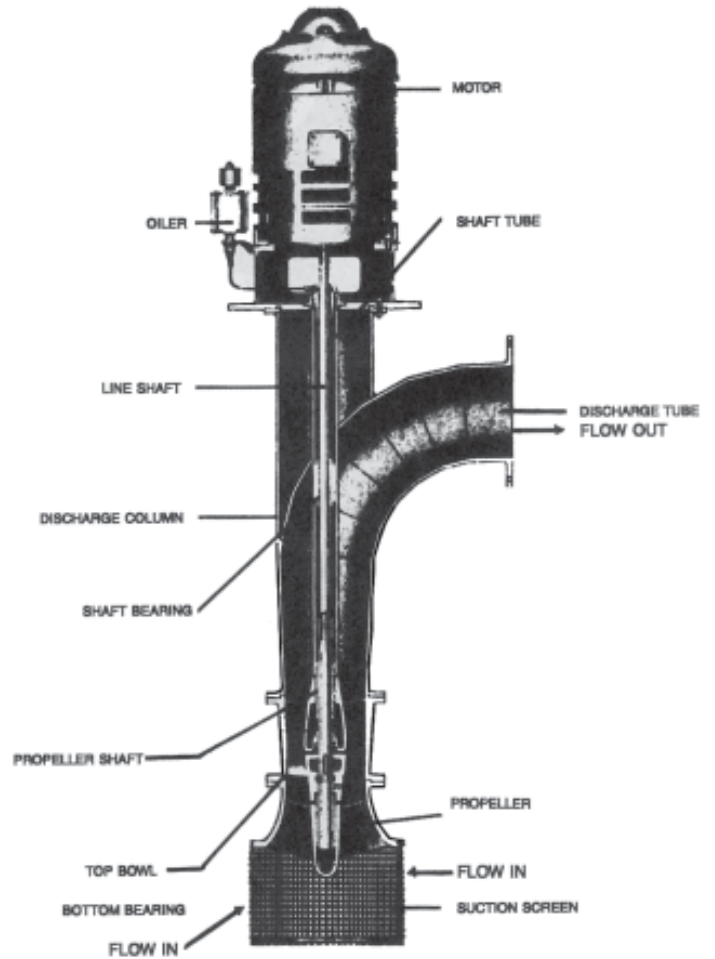


**Mixed-Flow**



**Axial-Flow**

**Figure 8.6**  
*Propeller-type Impellers*



**Figure 8.7 - Propeller Pump**

## POSITIVE DISPLACEMENT PUMPS

### RECIPROCATING OR PISTON PUMPS

The word “reciprocating” means moving back and forth, so a reciprocating pump is one that moves water or sludge by a piston that moves back and forth. A simple reciprocating pump is shown below. If the piston is pulled to the left, check valve A will be open and sludge will enter the pump and fill the casing.

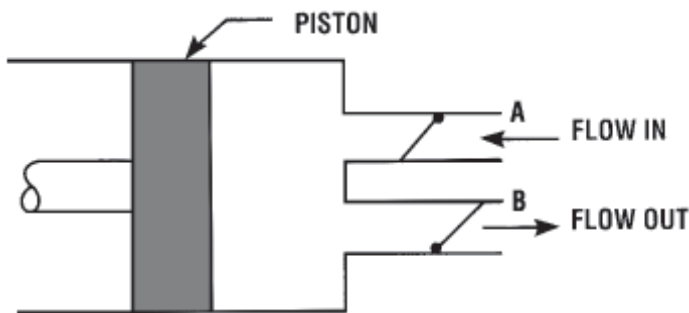
When the piston reaches the end of its travel to the left and is pushed back to the right, Check Valve A will close, Check Valve B will open, and wastewater will be forced out the exit line.

A reciprocating or piston pump is a positive-displacement pump. Never operate it against a closed discharge valve or the pump, valve, and/or pipe could be damaged by excessive

pressures. Also, the suction valve should be open when the pump is started. Otherwise an excessive suction or vacuum could develop and cause problems

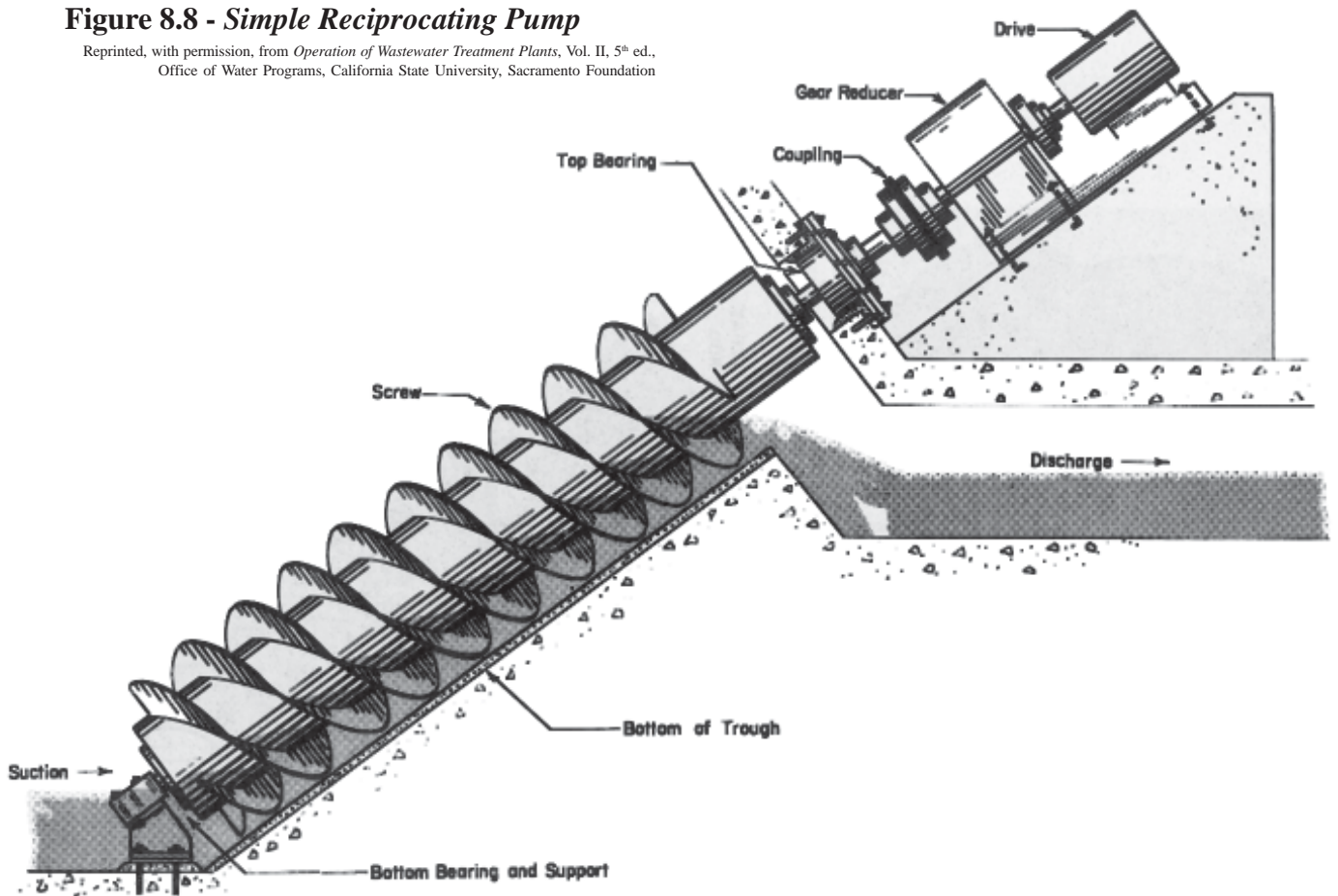
### INCLINE SCREW PUMPS

Incline screw pumps consist of a screw operating at a constant speed within a housing or trough. When the screw rotates, it moves the wastewater up the trough to a discharge point. Two bearings, one on top and one at the bottom, support the screw.



**Figure 8.8 - Simple Reciprocating Pump**

Reprinted, with permission, from *Operation of Wastewater Treatment Plants*, Vol. II, 5<sup>th</sup> ed., Office of Water Programs, California State University, Sacramento Foundation



**Figure 8.9 - Incline Screw Pump**



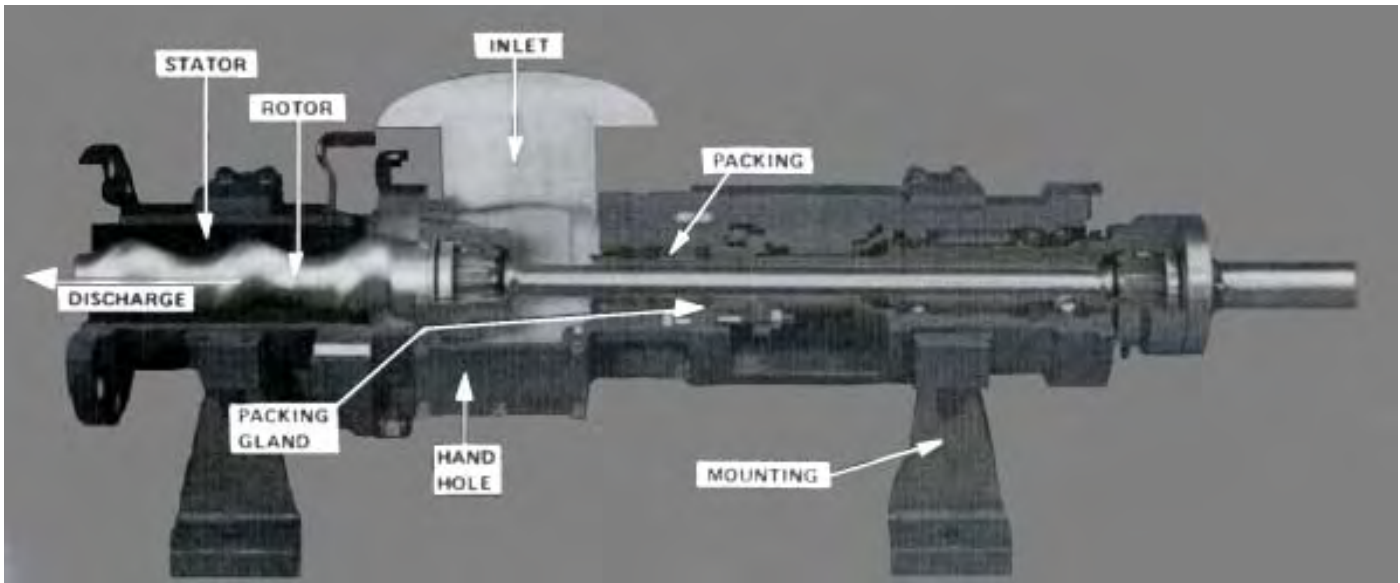


Figure 8.10 - *Progressive Cavity (screw-flow) Pump*

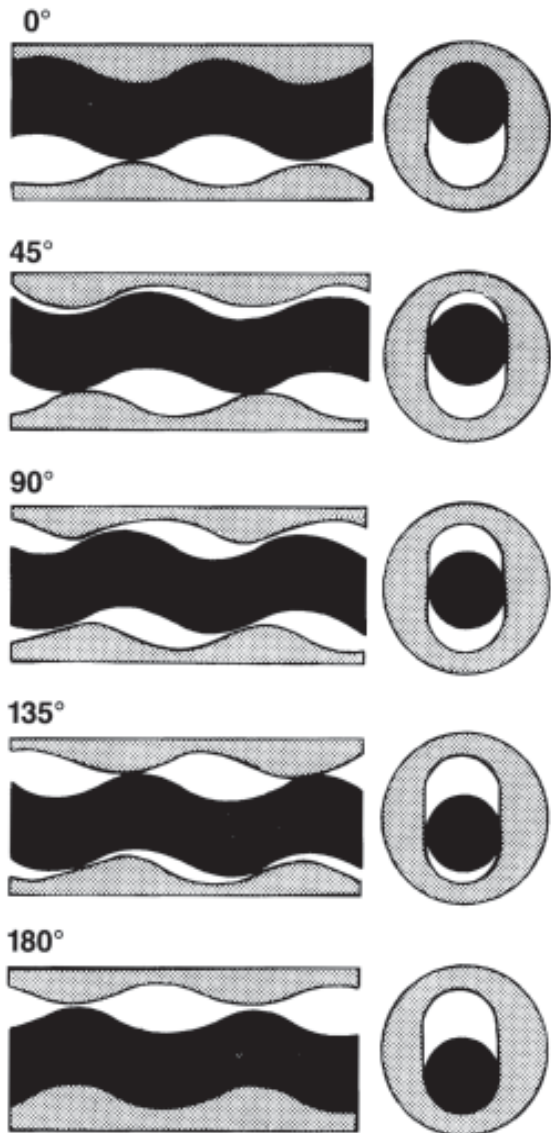


Figure 8.11 - *Pumping Principle of a Progressive Cavity Pump*

#### PROGRESSIVE CAVITY PUMPS

Operation of a progressive cavity pump is similar to that of a precision incline screw pump. The progressive cavity pump consists of a screw-shaped rotor snugly enclosed in a non-moving stator or housing. The threads of the screw-like rotor make contact along the walls of the stator (usually made of synthetic rubber). The gaps between the rotor threads are called "cavities." When wastewater is pumped through an inlet valve, it enters the cavity. As the rotor turns, the waste material is moved along until it leaves the conveyor (rotor) at the discharge end of the pump. The size of the cavities along the rotor determines the capacity of the pump.

These pumps are recommended for materials that contain higher concentrations of suspended solids. They are commonly used to pump sludges. Progressive cavity pumps should NEVER be operated dry (without liquid in the cavities), nor should they be run against a closed discharge valve.



## CENTRIFUGAL PUMP COMPONENTS

Before we can discuss operations and maintenance of a centrifugal pump, it is important to understand how a pump is put together and what the role is of each of the pump components. A centrifugal pump is constructed from about a dozen major components. Let's take a look at how these pieces fit together to make a pump.

The impeller is attached to the pump shaft. The shaft must be straight and true so that it will not cause vibration when it rotates. The shaft should be protected from potential damage caused by the failure of other pump parts. A shaft sleeve is used to protect the shaft in the area where the shaft passes through the pump casing.

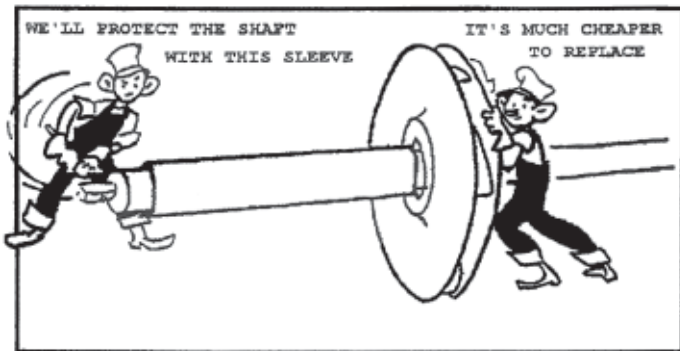


Figure 8.12 - Protecting the Shaft

The rotating assembly must be supported as it spins in the pump. Bearings hold the spinning shaft in place. There are two types of anti-friction bearings normally found in centrifugal pumps. One type of bearing is designed to keep the shaft from wobbling from side-to-side as it spins. This side-to-side motion is referred to as radial movement. The bearings used to prevent radial movement of the shaft are called radial bearings. The most common variety of radial bearing is the standard ball-type roller bearing.

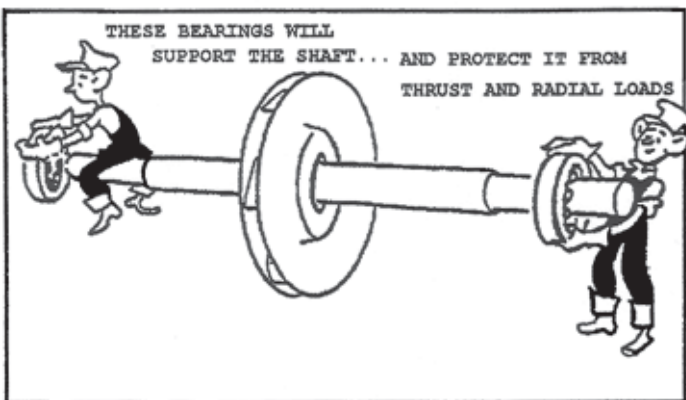


Figure 8.13 - Bearings

As the impeller spins, water entering the suction eye pushes against the top of the impeller exerting force in the same axis as the pump shaft. This is referred to as up thrust. The pressure developed inside the pump also pushes against the impeller in the opposite direction. This downward force is referred to as down thrust. Bearings designed to support the shaft against this type of force are called thrust bearings.

The most common variety of thrust bearing is an angular contact ball bearing.

The rotating assembly is placed in a pump casing. Part of the pump casing is specially designed to collect and direct the flow of water as it enters and leaves the impeller. This part of the pump casing is called the volute.

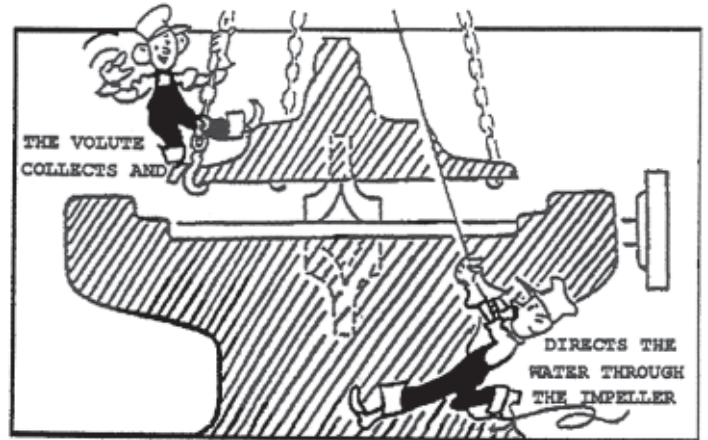


Figure 8.14 - Volute

The suction and discharge piping are attached to the pump casing. The suction piping will always be larger than the discharge piping. Suction piping is designed to bring water into the pump at 4 ft/sec in order to minimize the friction loss on the suction side of the pump. The discharge piping is designed to carry water away from the pump at 7 ft/sec.

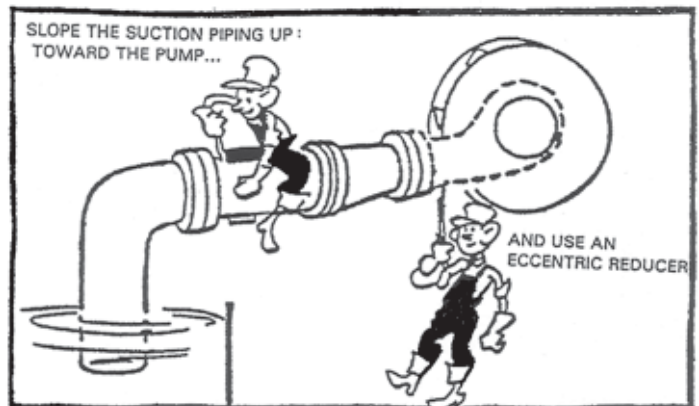


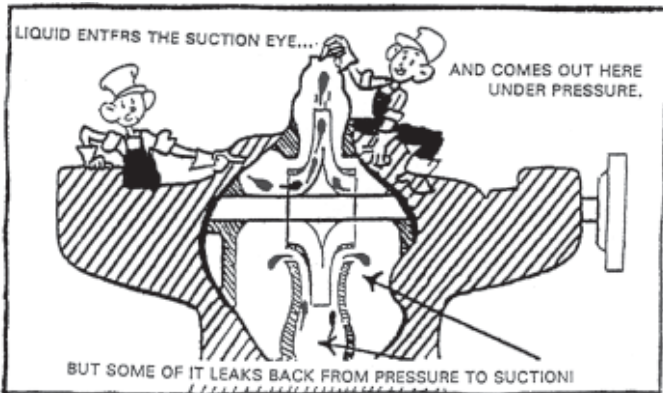
Figure 8.15 - Suction Piping Installation

There are several important aspects to suction piping installation. Horizontal runs of piping should slope upward toward the pump. Any reducers on the line should be horizontal across the top instead of tapered. A reducer that is flat on one side is known as an eccentric reducer. A reducer that is tapered on both sides is called a concentric reducer.

These installation features are used to prevent the formation of air pockets in the suction piping. Air trapped in the suction piping can create restriction of flow into the pump.

It is also important to make sure there are no leaks in the suction piping that might allow air to be drawn into the pump. The pump must never support the piping. Placing that kind of stress on the casing can cause it to crack or become sprung enough to cause damage to the rotating assembly.

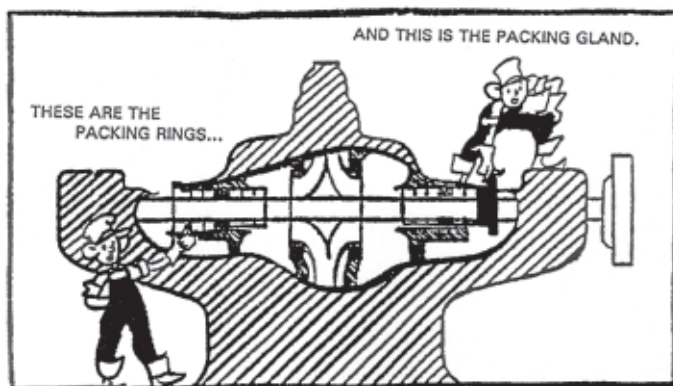
Now that the casing is assembled and the piping is in place, we can spin the impeller and begin moving water. Water will enter from the suction side of the volute and will be slung out of the impeller into the discharge side of the volute. Unfortunately, the water will try to pass from the high-pressure side back to the suction side and recirculate through the impeller again.



**Figure 8.16 - Recirculation through the Impeller**

The pump casing could have been machined to close this gap, but the fit would become worn and widened over time. To prevent this internal recirculation, rings are installed between the pump and the impeller that reduce the clearance between them to as little as 0.010". Unlike the casing, these rings are removable and can be replaced when they become worn. Because they wear out and get replaced, they are called wearing rings.

There is another area of the pump that will require some attention. Something must be done to plug the hole where the shaft enters the pump casing. This is a place where water can leak out and air can leak into the pump. Neither of these situations is acceptable. The part of the pump casing that the shaft passes through is called the stuffing

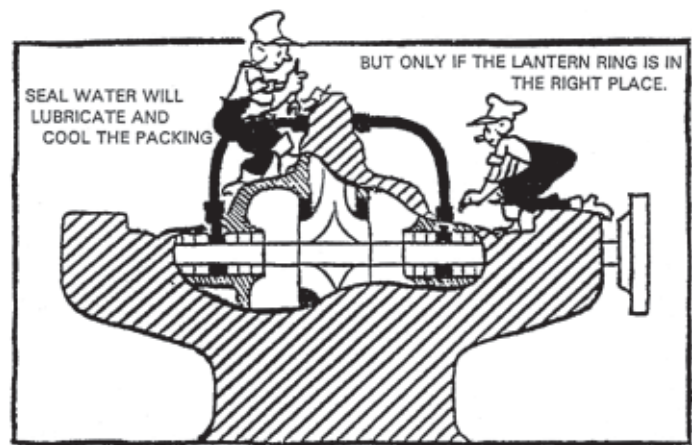


**Figure 8.17 - Packing Rings**

box. It's called the stuffing box because we are going to stuff something in the box to keep the water in and the air out.

This "stuffing" will usually be rings of pump packing. Several rings of packing are placed in the stuffing box. A metal insert ring fits on top of the stuffing box and is used to adjust or tighten the packing down to minimize water leakage. It is called a packing gland.

Since the packing rings touch the shaft sleeve as it rotates, friction and heat are generated in the stuffing box when the pump is running. Water is generally used to cool the packing rings during operation. This means that some water must leak out of the stuffing box when the pump is running. Water may simply be allowed to leak through the packing rings from inside the pump to cool them.



**Figure 8.18 - Lantern Ring**

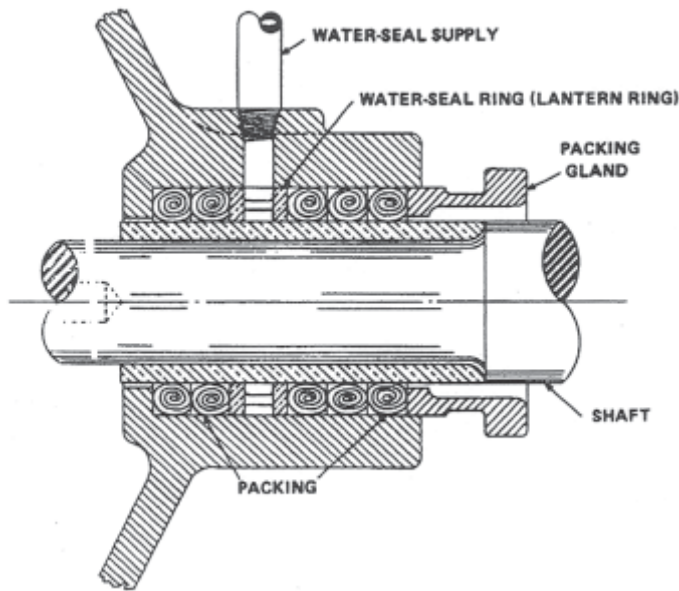
This water must come from the low-pressure side of the pump and may not be under enough pressure to leak past the packing rings when the packing gland is properly adjusted. If this is the case, high-pressure water from the discharge side of the pump may have to be piped into the stuffing box. Seal water piping is used to supply this water to the packing. The seal water enters the stuffing box from the outside, but it's needed on the inside between the packing and the shaft.

A lantern ring is used to get the water to the inside of the packing rings where the heat is being generated. The lantern ring is a metal ring that has holes in it. Water circulates around the outside of the lantern ring and passes through the holes to get to the inside of the packing rings. The lantern ring must be aligned with the seal water port on the stuffing box to make sure that water will get to the center of the stuffing box. Whenever a potable supply is used for a pump that is pumping non-potable water, an air gap or reduced pressure backflow preventer device must be used to prevent a possible cross-connection.

If there isn't enough seal water moving past the packing and rotating pump shaft to cool them properly, the packing will overheat. If the packing is allowed to overheat, the

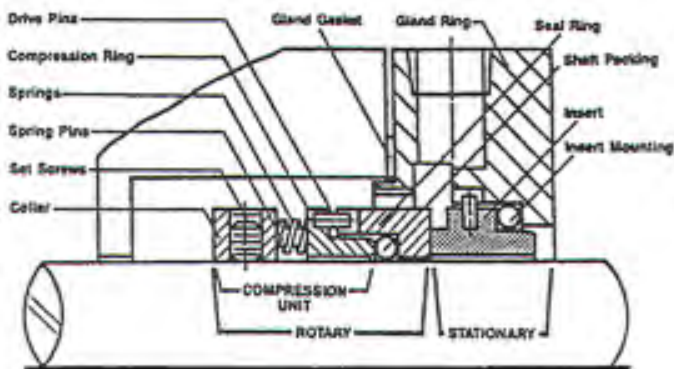


lubricant in the packing will be driven away from the shaft and the packing will become glazed, much like nylon cord that has been burned at the end. The glazed packing will then start cutting into the shaft sleeve, creating more friction and heat. The result will be packing failure and a severely damaged shaft sleeve.



**Figure 8.19 - Stuffing Box with Lantern Ring**

Pumps that do not have packing in the stuffing box will be equipped with a mechanical seal. Mechanical seals are comprised of two highly polished seal faces. One seal face is inserted in a gland ring that replaces the packing gland on the stuffing box. The other seal face is attached to the rotating shaft. It is held in place with a locking collar and is spring loaded so that there is constant pressure pushing the two seal faces together.



**Figure 8.20 - Mechanical Seal Components**

When the pump runs, seal water is piped into the stuffing box under enough pressure to force the seal faces apart. The seal faces don't touch when the pump is running, but the friction loss created as the water pushes them apart prevents any leakage from the gland plate. Failure of the seal water system will result in the seal faces rubbing against each other. The friction that is generated when this

happens can destroy a mechanical seal in a matter of seconds.

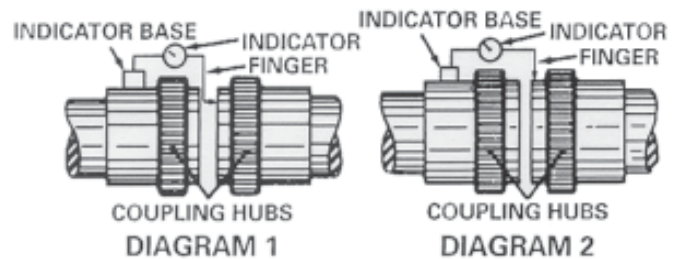
### ALIGNMENT

Whenever two pieces of rotating equipment such as a pump and motor are used, there must be some means of transmitting the torque from the motor to the pump. Couplings are designed to do this. To function as intended, the equipment must be properly aligned at the couplings. Misalignment of the pump and the motor can seriously damage the equipment and shorten the life of both the pump and the motor. Misalignment can cause excessive bearing loading as well as shaft bending which will cause premature bearing failure, excessive vibration, or permanent damage to the shaft. Remember that the purpose of the coupling is to transmit power and unless the coupling is of special design, it is not to be used to compensate for misalignment between the motor and the pump.

When connecting a pump and a motor, there are two important types of misalignment, (1) parallel and (2) angular. Parallel misalignment occurs when the centerlines of the pump shaft and the motor shaft are offset. The pump and the motor shafts remain parallel to each other but are offset by some degree.

Angular misalignments occur when the shaft centerlines are not parallel, but instead form an angle, which represents the amount of angular misalignment.

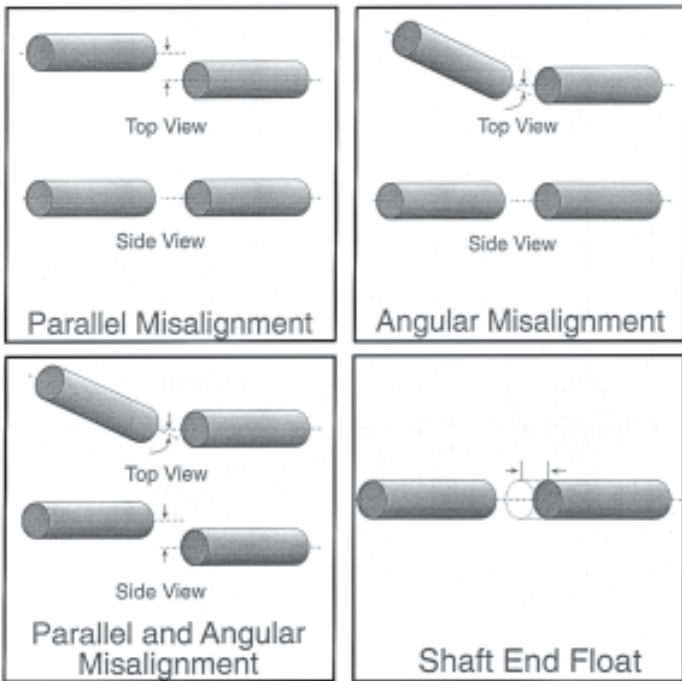
In reality, misalignment usually includes both parallel and angular misalignment. The goal when aligning machines is to reduce the angular and parallel misalignment to a minimum. Toward this end it is recommended that the use of a dial indicator be employed.



**Figure 8.21 - Use of Dial Indicator to Check for Shaft Angular Alignment and Trueness**

Reprinted, with permission, from *Operation of Wastewater Treatment Plants*, Vol. II, 5<sup>th</sup> ed., Office of Water Programs, California State University, Sacramento Foundation

The two types of misalignment and end float, which is an in-and-out movement of the shaft along the axis of the shaft, are shown below.



**Figure 8.22 - Types of Shaft Misalignment and End Float**

## BEARINGS

Pump bearings usually should last for years if serviced properly and used in their proper application. There are several types of bearings used in pumps such as ball bearings, roller bearings, and sleeve bearings. Each bearing has a special purpose such as thrust load, radial load, and speed. The type of bearing used in each pump depends on the manufacturer's design and application. Whenever a bearing failure occurs, the bearing should be examined to determine the cause and if possible, to eliminate the problem. Many bearings are ruined during installation or start-up. Bearing failures may be caused by:

1. Fatigue failure,
2. Contamination,
3. Brinelling,
4. False brinelling
5. Thrust failures
6. Misalignment,
7. Electric arching,
8. Lubrication failure,
9. Cam failure

## LUBRICATION

Pumps, motors, and drives should be oiled and greased in strict accordance with the recommendations of the manufacturer. For additional information read section 15.4 of the Operations of Wastewater Treatment Plants Vol. II.

## PUMP CHARACTERISTIC CURVES

Every pump has certain characteristics under which it will operate efficiently. These conditions can be illustrated with pump characteristic curves. The graph of the pump curve should show:

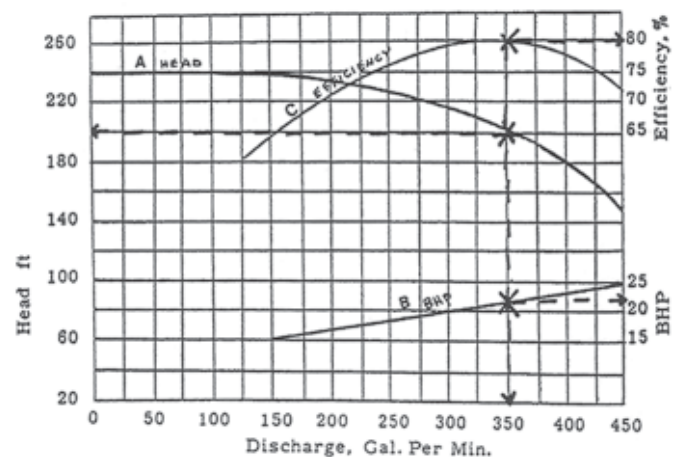
1. The head capacity curve (A)
2. The brake horsepower curve (B)
3. The efficiency curve (C)

The graph may contain a curve labeled "NPSH" (Net Positive Suction Head) instead of a BHP (Brake Horsepower) curve. NPSH represents the minimum dynamic suction head that is required to keep the pump from cavitating.

To use the pump curve:

1. Start at the particular head pressure that is desired and then travel across the chart to the point where it crosses the head capacity curve (A).
2. Drop a straight line from this point down to the bottom of the chart to determine the gpm output at that particular head pressure.
3. The brake horsepower can be determined by starting at the point where the vertical line crosses the horsepower curve (B) and going across to the right side of the chart. Use the same procedure for NSPH if it is used instead of BHP.
4. The efficiency of the pump at this flow and pressure is determined by starting at the point where the vertical line crosses the efficiency curve (C) and going over to the right side of the chart.

When the head pressure of the pump represented by this curve is 200 feet, the output is 350 gpm. The brake horsepower under these conditions is about 22 BHP and the efficiency is 80%. If the impeller or the speed of the pump changes, all of the pump's characteristics will also change.



**Figure 8.23 - Pump Curve**



## SHUT OFF HEAD

The highest head pressure that the pump will develop is called the “shut off head” of the pump. The shut off head for the pump in this curve is 240 feet of head. When a pump reaches shut off head, the flow from the drops to 0 gpm. This is a valuable piece of information for conducting a quick check of the pump’s performance. If the pump cannot generate its rated shut off head, the pump curve is no longer of any real value to the operator. A loss of shut off head is probably caused by an increase in recirculation inside the pump due to worn wear rings or worn impellers.

There is another factor that might affect the shut off head of the pump. The pump curve assumes that the pump is running at design speed. If a pump that is designed to spin at 1750 rpm and it is only turning at 1700 rpm, the shut off head will also be lower than the pump curve. However, if the pump speed is checked with a tachometer and found to be correct, the wear rings or impellers are probably in need of repair.

## CHECKING SHUTOFF HEAD

It is fairly easy to check the shut off head on a pump if it has suction and discharge pressure gauges.

1. Start the pump and close the discharge isolation valve. This will create a shut off head condition since the flow has been reduced to 0 gpm. The pump should not operate at shut off head for more than a minute or it will begin to overheat.

**NOTE:** NEVER attempt to create shut off head conditions on a multi-staged turbine well. The shut off head may be several hundred feet higher than normal operating pressure, which can cause damage to piping.

2. With the pump running at shut off head, read the suction and discharge pressure gauges. Subtract the suction pressure from the discharge pressure to get

the shut off head. Compare the field readings to the pump curve to see if the wear rings are in need of replacement.

If the shut off head matches the curve, the same calculation can be used when the pump is running normally, to estimate the Total Dynamic Head (TDH) and determine the flow when a meter is not available.

## COMMON OPERATIONAL PROBLEMS

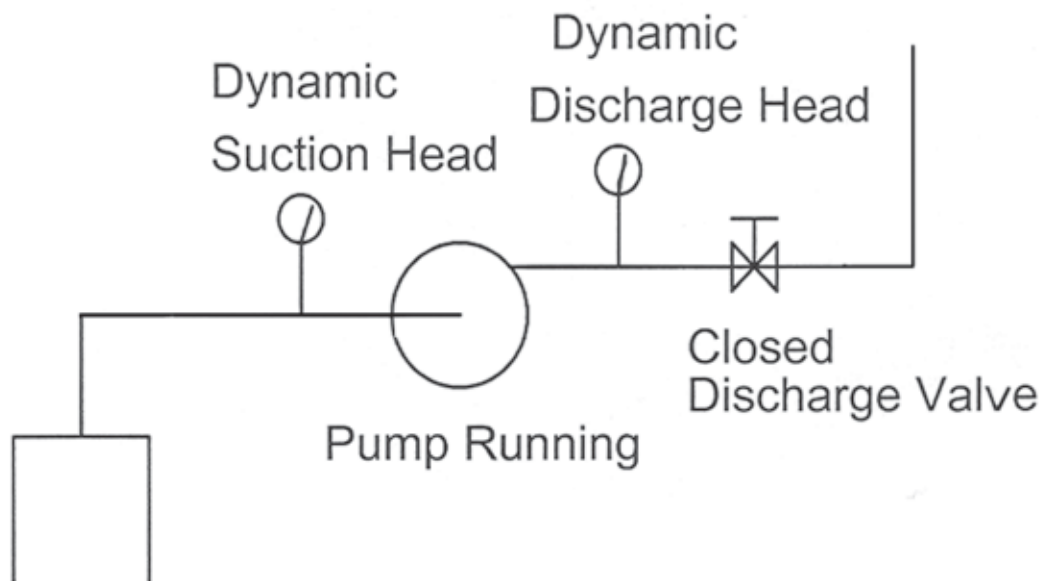
The operator should check all pumps and motors every day to insure proper operation. After spending a certain amount of time with these pumps and motors an operator should be able to tell just by listening to them whether they are work-ing properly. The vast majority of pumping problems are either a result of improperly sizing a pump for the job or one of the three following operational problems.

### CAVITATION

One of the most serious problems an operator will encounter is cavitation. It can be identified by a noise that sounds like marbles or rocks are being pumped. The pump may also vibrate and shake, to the point that piping is damaged in some severe cases. Cavitation occurs when the pump starts discharging water at a rate faster than it can be drawn into the pump. This situation is normally caused by the loss of discharge head pressure or an obstruction in the suction line. When this happens, a partial vacuum is created in the impeller causing the flow to become very erratic. These vacuum-created cavities are formed on the backside of the impeller vanes.

As the water surges into the impeller, the partial vacuum is destroyed and the cavities collapse, allowing the water to slam into the impeller vanes. These cavities form and collapse several hundred times a second. As they collapse, they draw the water behind them into the impeller at about 760 mph! The impact created by the water slamming into the impeller is so great that pieces of the impeller may be chipped away.

When cavitation occurs, immediate action must be taken to prevent the impeller, pump and motor bearings, and piping from being damaged. Cavitation can be temporarily corrected by throttling the discharge valve. This action prevents damage to the pump until the cause can be found and



$$\text{Shut off Head} = \text{Dynamic Discharge Pressure} - \text{Dynamic Suction Pressure}$$

Figure 8.24 - Shut Off Head

corrected. Remember that the discharge valve is there to isolate the pump, not control its flow. If it is left in a throttled position the valve face may become worn to the point that it won't seal when the pump is isolated for maintenance.

**Table 8.2 - Causes of Cavitation**

- 
- Loss of discharge pressure due to open hydrants or line breaks
  - Closed suction valve
  - Obstruction in the suction line
  - Low suction head due to drop in water level
- 

### **AIR LOCKING**

Air locking is another common problem with pumps. It is caused by air or dissolved gases that become trapped in the volute of the pump. As the gas collects, it becomes compressed and creates an artificial head pressure in the pump volute. As more air collects in the pump, the pressure will continue to build until shut off head is reached. Air locking is most often caused by leaks in the suction line. The failure of low-level cut-off switches, allowing air in from the wet well, may also cause air locking.

An air locked pump will overheat in a matter of minutes. The shut off head condition means that no water is moving through the pump. Vertical pumps that use internal leakage to cool packing may also experience packing ring failure, since the trapped air can prevent water from reaching the packing.

Air relief valves are used to prevent air locking. They are located on the highest point on the pump volute and automatically vent air as it accumulates in the pump. It is also a good idea to repair leaking gaskets and joints on the suction piping. If the pressure in the line drops below atmospheric pressure when the pump is running, air will leak in instead of water leaking out.

### **LOSS OF PRIME**

Loss of prime happens when water drains out of the volute and impeller. The impeller can't create any suction at the impeller eye unless it is filled with fluid. This occurs only when negative suction head conditions exist. Pumps that operate with negative suction lift are usually installed with a foot valve or check valve at the bottom of the suction pipe. This valve holds the water in the suction pipe and pump when the pump is off.

When a pump loses its prime it must be shut down, reprimed, and all the air bled out of the suction line before starting the pump again. Worn packing and a defective foot valve normally cause loss of prime. The best way to prevent loss of prime is to design a pump installation so that there is positive suction head on the pump.

## **ELECTRICITY**

Very few operators do electrical repairs or trouble shooting because this is a highly specialized field and unqualified operators can seriously injure themselves or damage costly equipment. For these reasons the operator must be familiar with electricity, know the hazards, and recognize his/her own limitations when working with electrical equipment.

Most municipalities employ electricians or contract with a "commercial electrical company" that they call when major problems occur. However, the operator should be able to explain how the equipment is supposed to work and what it is doing or not doing when it fails.

The need for safety should be apparent. If proper safe procedures are not followed in operating and maintaining electrical equipment, accidents can happen that cause injuries, permanent disability, or loss of life. Serious accidents that could have been avoided have happened because machinery was not shut off, locked out, and tagged properly.

Due to the nature of electricity it is suggested you read and understand the chapter on electricity in the Small Wastewater System Operation and Maintenance By California State University, Sacramento or the Operation of Wastewater Treatment Plants Vol. II.

### **ELECTRIC MOTORS**

Electric motors are commonly used to convert electrical energy into mechanical energy. A motor generally consists of a stator, rotor, end bells, and windings. The rotor has an extending shaft, which allows a machine to be coupled to it. Most large motors will be three phase motors rated from 220 or 4160 volts.

### **PHASES**

The term "phase" applies to alternating current (AC) systems and describes how many external winding connections are available from a generator, transformer, or motor for actual load connections. Motors are either single-phase or three-phase.

#### Single Phase Motors

Single-phase motors are normally operated on 110-220 volt A.C. single-phase systems. A straight single-phase winding has no starting torque so it must incorporate some other means of spinning the shaft. A single-phase motor requires a special start circuit within the motor to make sure it runs in the right direction. Several different types of starter windings are available in these motors. Single-phase power leads will have three wires, like a three-prong extension cord.

#### Three Phase Motors

Three-phase systems refer to the fact that there are three sets of windings in the motor and three legs of power coming in from the distribution system. This type of motor is used where loads become larger than single-phase circuits can handle. With three legs to carry power, more amps can

be delivered to the motor. Three phase motors are the most common types used in water and wastewater systems. Three major types of three phase motors are the squirrel cage induction motor, synchronous motors, and wound rotor induction motors.

Squirrel cage induction motors are widely used because of its simple construction and relative low maintenance requirements. The windings are stationary and are built into the frame of the motor. The power supply is connected to the windings in the stator, which creates a rotating magnetic field. The rotor is made up of bars arranged in the shape of a cylinder and joined to form a “squirrel cage.” Squirrel cage induction motors make up approximately 90% of all motors used in industry today.

Three-phase motors do not use a start circuit. The direction of rotation is determined by how the three leads are wired to the motor. If any two of the leads are switched, the motor rotation will be reversed.

### Single Phasing

Anytime a lead becomes grounded, a dead short develops, or one of the contacts opens in a three-phase motor, single phasing will result. When this occurs, the speed of the motor will drop and it will begin to overheat. The single phase will draw too many amps and it will quickly burn up. When single phasing occurs while the motor is not running, it simply will not start up again. Special circuit protection is available that will shut the motor off if single phasing occurs.

### **CIRCUIT PROTECTION**

Motors need to be protected from power surges and overloads. Fuses and circuit breakers are designed to open the circuit when the current load threatens to damage the motor. Fuses are generally sized at 120-150% of motor capacity. Circuit breakers can be reset when they trip, instead of being replaced like a fuse. Circuit breakers can react faster than fuses and are usually sized closer to the current rating of the motor.

### ***References***

Office of Water Programs, California State University, Sacramento, *Operation of Wastewater Treatment Plants*, Volume II, 5<sup>th</sup> ed., Chapter 15

## CHAPTER 9: DISINFECTION

---

Disease-producing microorganisms are potentially present in all wastewaters. These microorganisms must be removed or killed before treated wastewater can be discharged to the receiving waters. The purpose of disinfection is to destroy pathogenic microorganisms and thus prevent the spread of water borne diseases.

Although pathogenic microorganisms are reduced in number by the various treatment processes and by natural die-off in unfavorable environments, many microorganisms still remain. To ensure that essentially all pathogenic microorganisms are destroyed in the effluents of wastewater treatment plants, disinfection is practiced. Since chlorine is the most widely used chemical for disinfection, this chapter will deal primarily with the principles and practices of chlorine disinfection and dechlorination. At the end of this chapter another method of disinfection that is increasingly being used in wastewater treatment plants ultraviolet (UV) light systems is discussed.

Two terms you should understand are “disinfection” and “sterilization.” Disinfection is the destruction of all pathogenic microorganisms, while sterilization is the destruction of all microorganisms.

The main objective of disinfection is to prevent the spread of disease by protecting:

1. Public water supplies
2. Receiving waters for recreational uses, and
3. Shellfish growing areas.

Disinfection is effective because pathogenic microorganisms are more sensitive to destruction by chlorination than nonpathogens. Chlorination for disinfection purposes results in killing essentially all of the pathogens in the plant effluent. No attempt is made to sterilize wastewater because it is unnecessary and impractical.

Chlorine is the most widely used disinfectant because it is readily available, easily applied, and cheaper than other oxidizing agents such as potassium permanganate ( $\text{KMnO}_4$ ), chlorine dioxide ( $\text{ClO}_2$ ), or ozone ( $\text{O}_3$ ). Chlorine is applied in one of three forms; chlorine gas, chlorine powder (HTH), or an aqueous solution like chlorine bleach. Even at relatively low dosages, chlorine is extremely effective.

### REACTION OF CHLORINE IN WASTEWATER

Chlorine is applied to wastewater as free chlorine ( $\text{Cl}_2$ ) Hypochlorite ion ( $\text{OCl}^-$ ), or as chlorine dioxide ( $\text{ClO}_2$ ). In either the free chlorine or Hypochlorite ion form, chlorine

is an extremely active chemical and acts as a potent oxidizing agent. Since chlorine is very reactive, it is often used up by side reactions before disinfection takes place. These side reactions can be with such substances as organic material, hydrogen sulfide, phenols, thiosulfate, and ferrous iron. These side reactions occur first and use up a major portion of the chlorine necessary to meet the chlorine demand for a wastewater.

### CHLORINE TREATMENT TERMS

Several terms are used to identify the various stages and reactions that occur when chlorine is used as a disinfectant. The basic unit of measurement for chlorination, or any other chemical treatment is milligrams per liter (mg/l) or parts per million (ppm). These are very small units reflecting concentrations that are essentially one part chemical for every million parts of water. To get some idea of how small a concentration this really is it should be pointed out that 1% is equal to 10,000 mg/l or ppm.

### CHLORINE DOSAGE

The chlorine dosage is the amount of chlorine that is added to the water. The dosage can be determined from the number of pounds of chlorine used and the number of millions of pounds of water treated.

### CHLORINE DEMAND

Chlorine is a very reactive oxidizing agent. It will react with certain substances that may be found in water. This list includes; iron, manganese, hydrogen sulfide, organic compounds and ammonia. When chlorine reacts with these substances, it loses its disinfecting properties. This is referred to as the chlorine demand. For chlorine to be effective as a disinfectant, the dosage must always exceed the demand that is present in the water. The chlorine demand may vary from day to day in a surface water supply. It is usually fairly constant in a ground water supply.

### CHLORINE RESIDUAL

The chlorine that remains in the water, after it has finished reacting with those substances that represent the demand, is known as the chlorine residual. The concentration of the residual is determined by subtracting the demand from the dosage.

#### EXAMPLE:

A 4.0 mg/l dosage is added to water that has a demand of 2.5 mg/l. What is the residual?

$$\begin{array}{rcl} \text{Dosage} & - & \text{Demand} & = & \text{Residual} \\ 4.0 \text{ mg/l} & - & 2.5 \text{ mg/l} & = & 1.5 \text{ mg/l Residual} \end{array}$$



There are two types of residuals that result from the chlorination of water. They are free chlorine residual and combined chlorine residual.

### FREE CHLORINE RESIDUAL

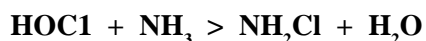
After the demand has been satisfied, any chlorine that is left will react with water to form hydrochloric acid and hypochlorous acid.



The hypochlorous acid is the disinfecting agent and the presence of the hypochlorous ion ( $\text{OCl}^-$ ) is measured to obtain the free chlorine residual.

### COMBINED CHLORINE RESIDUAL

Chlorine reacts with water to form hypochlorous acid. If ammonia is present, the hypochlorous acid will react with it to form compounds known as chloramines.



Chloramines are found in three forms. They may contain from one ( $\text{NH}_2\text{Cl}$ ) up to three ( $\text{NCl}_3$ ) atoms of chlorine. The chemistry of the water and concentration of chlorine will dictate which of the chloramines are formed. Chloramines are weak disinfectants. They require longer contact times and higher concentrations to achieve disinfection than free chlorine residual. However, they do not breakdown as quickly as free chlorine and remain in the system longer.

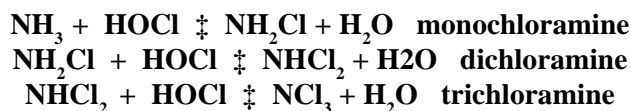
### EFFECTS OF TEMPERATURE AND PH

Changes in temperature and pH of the water can reduce the effectiveness of chlorine. Colder temperatures slow down reaction times requiring higher concentrations and longer contact times to achieve proper disinfection. A high pH impedes the formation of the hypochlorous acid and requires a higher dosage to obtain the proper residual.

### BREAKPOINT CHLORINATION

Since ammonia is present in all domestic wastewaters, the reaction of ammonia with chlorine is a great significance. When chlorine is added to waters containing ammonia, the ammonia reacts with hypochlorous acid ( $\text{HOCl}$ ) to form monochloramine, dichloramine and trichloramine. The formation of these chloramines depends on the pH of the solution and the initial chlorine-ammonia ratio.

Ammonia + Hypochlorous Acid  $\rightarrow$  Chloramine + Water



In general at the pH levels that are usually found in wastewater (pH 6.5 to 7.5), monochloramine and dichloramine exist together. At pH levels below 5.5, dichloramine exists by itself. Below pH 4.0, trichloramine is the only compound found.

The mono- and dichloramine forms have definite disinfection powers and are of interest in the measurement of chlorine residuals. Dichloramine has a more effective disinfecting power than monochloramine.

If enough chlorine is added to react with the inorganic compounds and nitrogenous compounds, then this chlorine will react with organic matter to produce chlororganic compounds or other combined forms of chlorine, which have a slight disinfecting action. Then if enough chlorine is added to react with all the above compounds, any additional chlorine will exist as Free Available Chlorine, which has the highest disinfecting action. The term 'Breakpoint Chlorination' refers to the breakpoint shown below.

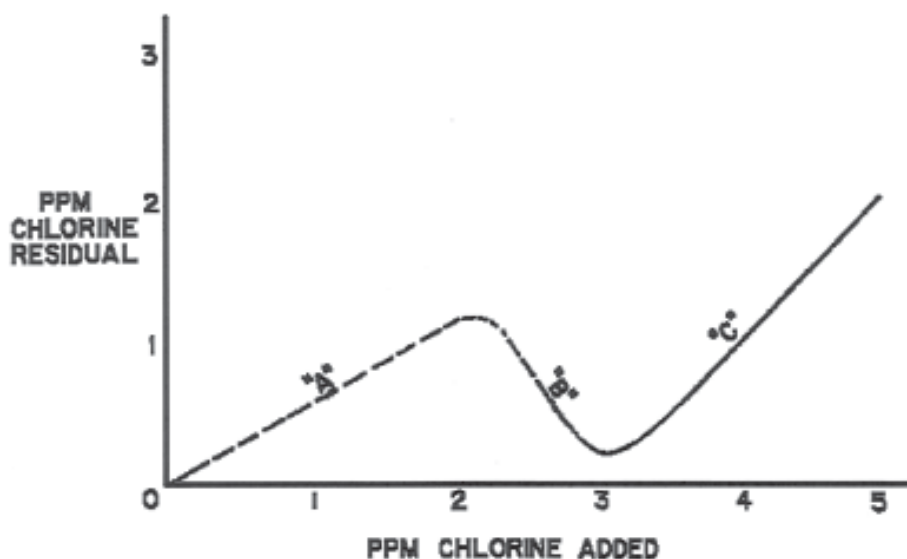


Figure 9.1 - Breakpoint Chlorination Curve

The Breakpoint Curve shown above illustrates the formation and destruction of chloramines before free residuals are achieved. Every system's breakpoint will vary depending on the chemical makeup and chlorine demand of the raw wastewater.

As chlorine is added to the water, it reacts with the ammonia that is present and a combined residual reading is obtained (A). In this case, as the dosage increases to about 2ppm (mg/l) the combined residual drops because the chloramines are being destroyed (B). When the dosage reaches 3ppm (mg/l), the breakpoint occurs and first free chlorine residual is obtained. Once the breakpoint has been reached, the free residual will increase at the same rate as the dosage (C). There may still be some combined residual in the water even though the breakpoint has been reached, but it will remain at this minimum level as long as the dosage is greater than 3 ppm (mg/l).

### TESTING FOR CHLORINE RESIDUALS

There are three methods that are used to test water for chlorine residual. Amperometric titration provides for the most convenient and the most repeatable results; however, the equipment costs more than equipment for the other methods. The Amperometric titration is most often used in the laboratory. Two other methods are field tests - the Ortho-Tolidine-Arsenite (OTA) test, which was the industry standard until the mid -1970's, and the DPD method. Problems were found with the OTA test in that iron and nitrites in the water would interfere with the test. In addition, OTA was found to be a carcinogen. It is no longer used for chlorine residual testing today. Instead, the Diethyl-p-Phenylene-Diimine (DPD) test is used for fieldwork.

The DPD test is a colorimetric analysis. The reagent is added to a vile of sample water. Another vile of sample water serves as a "blank." If chlorine is present the sample will turn pink or red. The blank is placed in front of the "color wheel" and the sample is compared to the color wheel and blank. There are two chemical packets for the DPD test. One is used for free chlorine and the other is used for total chlorine residual. Subtracting the free residual from the total residual will give you the combined residual.

For additional information on chlorine testing refer to Chapter 14 -Laboratory Procedures

### CHLORINE GAS

Chlorine gas (Cl<sub>2</sub>) is compressed into a liquid for storage. It can be purchased in cylinders containing 150 or 2000 pounds of the liquefied gas. Chlorine gas is cheaper per pound than either of the other forms.

### CHLORINE POWDER

Chlorine in its dry form is calcium hypochlorite [Ca(OCl)<sub>2</sub>]. It is also most commonly known by the trade name HTH (High Test Hypochlorite). Only about 65 – 70% of the HTH is available as chlorine. The rest is calcium, which is not a

disinfectant. Dry chlorine is 2-3 times more expensive, per pound of chlorine, than chlorine gas.

### CHLORINE BLEACH

Chlorine bleach is a liquid solution of sodium hypochlorite (NaOCl). Bleach is usually 3 – 12% available chlorine and 88 – 97% water. Bleach is the most expensive form of chlorine.

### GENERAL CHLORINE SAFETY

Chlorine is a greenish-yellow gas. It is 2.5 times heavier than air. Chlorine gas is very corrosive. It turns into hydrochloric acid when it comes in contact with moisture (in the water, in the chlorine lines, or in your eyes or lungs). It does not support combustion though. It can be harmful if inhaled in small quantities and fatal in larger doses. Table

<b>SYMPTOM</b>	<b>CONCENTRATION</b>
Noticeable odor	0.2 ppm
Irritation after several hours	1.0 ppm
Irritation of throat after a few minutes	15 ppm
Immediate coughing	30 ppm
Dangerous after 30 minute exposure	40 ppm
Lethal in minutes	1000 ppm

lists the effects of chlorine gas in various concentrations in the atmosphere.

Because of the potential for injury to workers and the general public from chlorine gas accidents, safety must always be the first consideration when it is handled.

### CHLORINATOR ROOM

The chlorinator room should have a window in the door so that the operator in the room can be seen from the outside. The light and vent switches should also be located outside the room. The room should have ventilation located at floor level since chlorine gas is heavier than air and will settle in the lowest spot in the room.

The room should be kept between 60° F and 120° F. Below 60° F, chlorine gas forms chlorine hydrate, also known as "green ice," when it comes in contact with water. This green ice can clog the injector and gas piping, creating a serious maintenance problem.

When a chlorine cylinder is full and at room temperature, it is about 85% full of liquefied chlorine. As the

temperature rises, the liquid expands and takes up more space in the cylinder. At 157° F the liquid will expand to occupy 100% of the cylinder. If the liquid expands any further the cylinder will rupture, causing a massive chlorine leak.

NEVER enter a chlorine facility without ventilating for several minutes first. The National Fire Code now requires that new gas chlorine facilities be equipped with a scrubber system that will remove chlorine gas that may be present in the ventilation exhaust. These systems must have a backup power supply to keep the scrubber running in the event of a power failure. Check with local Fire authorities before new chlorine facilities are built to make sure they will be in compliance.

### CHLORINE STORAGE

The room where chlorine cylinders or HTH drums are stored must be kept dry and well ventilated. Chlorine should always be stored in a room separate from other chemicals. Chlorine cylinders that are empty should be separated from those that are full. When not in use, all cylinders should be chained to the wall.

### CHLORINE CYLINDERS

NEVER remove the valve hood from a chlorine cylinder unless it is chained to the scales and ready to be put on the system. All cylinders should be chained to the wall or the scales unless they are being moved. Emergency repair kits are available that can be used to seal leaks in the broken valves or leaking cylinders. Every system that operates a gas chlorine system should have an emergency kit or be able to get access to one on very short notice.

To prevent the cylinder from rupturing when it gets too hot, every gas cylinder will have a “fusible plug” that is designed to melt at 157° F. There is one in the valve assembly of every 150 lb. Cylinder and six (three on each end) in the body of every 1-ton cylinder. As one of these fusible plugs melts, it will allow the release of chlorine gas from the cylinder. This still represents a serious problem, but the release will be more gradual than it would if the tank ruptured.

### HTH HANDLING SAFETY

Powdered chlorine should be stored in a cool dry place separate from other chemicals. HTH must never be allowed to come in contact with petroleum products or organic solvents. If this happens, it will explode violently! This is also true for the other forms of chlorine, but is more likely to occur during the handling of HTH. Care must also be taken to avoid contact with the eyes or bare skin.

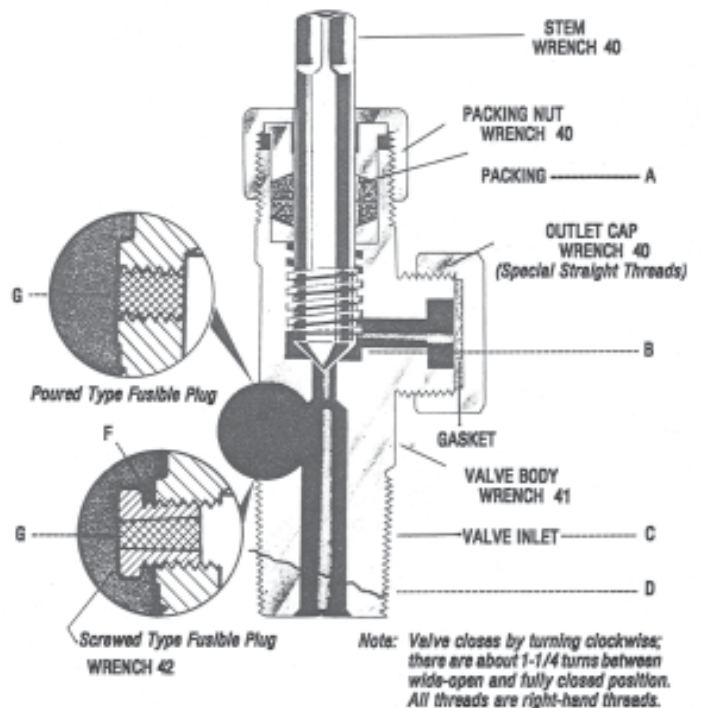
### RESPIRATORY PROTECTION

Anyone involved in handling chlorine should have access to respiratory protection equipment. Chlorine gas forms hydrochloric acid when it gets in the eyes or lungs. This can result in serious injury or death depending on the concentration and exposure time. The damage caused by exposure to chlorine gas is cumulative. Several incidents involving minor exposure can contribute to serious health problems at sometime in the future.

There are two basic types of respiratory protection. One is the gas mask that uses a filtering device to remove chlorine. These are either a full-face mask or a mouth/nose type respirator. The other type of respirator is the self-contained breathing apparatus (SCBA). The SCBA unit is full-face mask with an air tank to provide the operator with fresh air to breathe when in hazardous atmospheres. Both of these devices may be rendered ineffective if the wearer has facial hair that interferes with the face-to-mask seal.

### GAS MASKS

The gas mask is designed to allow the operator time to escape the chlorine room when a leak occurs. **THESE DEVICES ARE INTENDED FOR ESCAPE PURPOSES ONLY! A GAS CANISTER MASK MUST**



#### TYPICAL VALVE LEAKS OCCUR THROUGH . . .

- |                         |                           |
|-------------------------|---------------------------|
| A - VALVE PACKING GLAND | E - VALVE BLOWN OUT       |
| B - VALVE SEAT          | F - FUSIBLE PLUG THREADS  |
| C - VALVE INLET THREADS | G - FUSIBLE METAL OF PLUG |
| D - BROKEN OFF VALVE    | H - VALVE STEM BLOWN OUT  |

Figure 9.2 - Chlorine Cylinder Valves

**NEVER BE USED TO ENTER ANY AREA WHERE CHLORINE GAS IS PRESENT!** If the release of chlorine drops the oxygen concentration below 12%, it is impossible to survive even if all the chlorine is filtered out. If an operator is wearing a canister mask he must still leave the area immediately upon detection of a chlorine leak. The gas canisters should be changed every six months or anytime it has been exposed to chlorine gas.

**SELF-CONTAINED BREATHING APPARATUS (SCBA)**

The SCBA unit must be used when working in a chlorine gas atmosphere. It has an air tank that allows the wearer to breathe uncontaminated air while attempting to correct a chlorine leak situation. The SCBA tank will hold enough air for approximately 30 minutes, depending on working conditions. When the air pressure drops to a point where there is about five minutes of air remaining in the tank (500 psi), an alarm will ring to signal the operator that it is time to exit the area and change tanks.

**CHLORINATION EQUIPMENT**

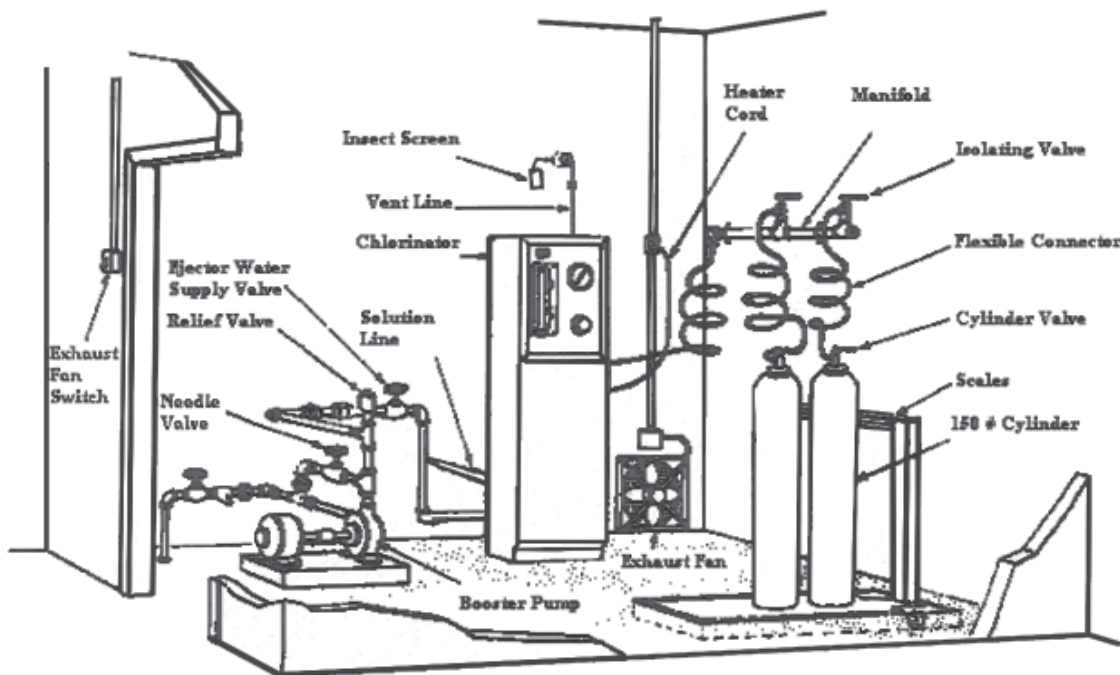
There are two ways to feed chlorine into the water system. Gas chlorination uses liquefied chlorine gas. Hypochlorination uses a positive displacement pump to feed a solution of dissolved HTH or bleach into the system. Many smaller systems will use a hypochlorination system because the equipment cost is lower. The solution of dissolved HTH or bleach is much easier to handle and presents less of a risk compared to a gas system. Gas chlorinating is used where the system requires larger dosages of chlorine than can be delivered by

hypochlorination. Though capital costs are higher for gas chlorination, the chemical costs are significantly lower than when HTH or bleach is used.

**GAS CHLORINATION**

A gas chlorine system consists of one or more gas cylinders connected to gas chlorinator. The gas chlorinator consists of a pressure regulating valve, a feed rate indicator, a flow-regulating device (a V-notch plug or needle valve), and an injector or ejector. The chlorine pressure-regulating valve (CPRV) opens when a vacuum is created by the injector and maintains a constant negative pressure inside the chlorinator. The feed rate indicator consists of a ball floating inside a glass tube. The feed rate is indicated on the glass tube and is read in “pounds per day.” The feed rate should be read at the widest point of the ball or bead. The feed rate is controlled using the needle valve or V-notch plug. Water flowing past the injector creates a vacuum that draws the gas into the system.

The maximum feed rate for gas drawn from a 150 lb. Cylinder is 40 pounds/day. The maximum gas feed rate for a 1-ton cylinder is 400 pounds/day. If these feed rates are exceeded, the tanks will frost over because heat can't pass through the tanks as fast as it is used to evaporate the chlorine from a liquid to a gas. This can also occur in situations where several tanks are manifolded to the chlorinator. If one of the cylinder valves is partially closed the other tanks may try to feed too much gas and frost over. When this happens, check the tank that isn't frosted for a closed valve or plugged pigtail line. Ton cylinders are



**Figure 9.3 - Gas Chlorination Installation (150 Lb. Cylinders)**



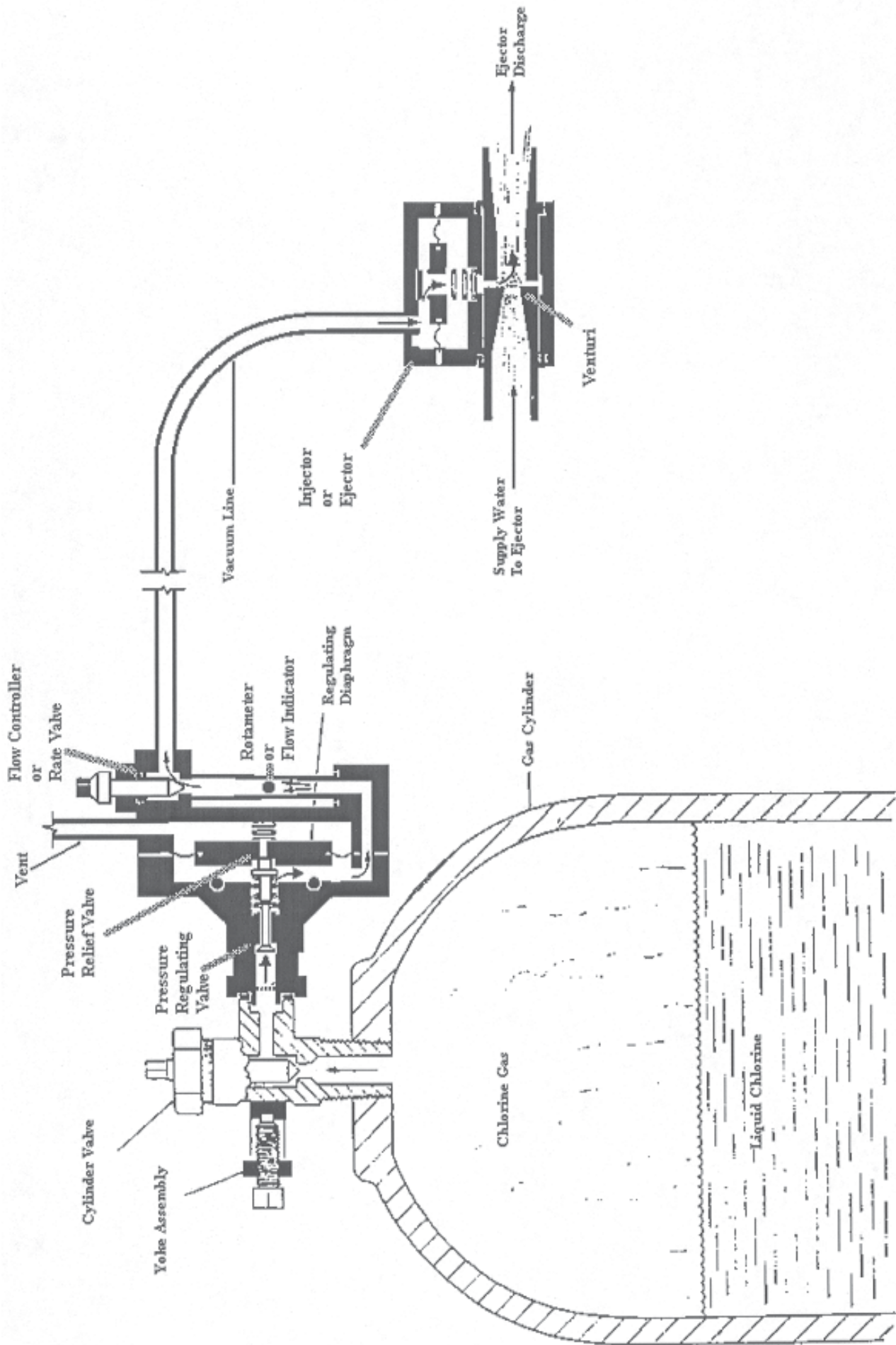


Figure 9.4 - Chlorine Gas Cylinder Cross Section

sometimes set up to feed liquefied gas. These systems used an evaporator to change the liquid to a gas before it goes to the chlorinator. There is no limit to how much liquid chlorine can be removed from a cylinder since the heat for evaporation is supplied by an outside source. NEVER manifold cylinders together when feeding liquefied chlorine to an evaporator. Expansion tanks equipped with rupture disks are used to protect all liquid feed piping. These provide protection from expansion of liquefied gas that may become isolated in the line.

### EVAPORATORS

Chlorine Evaporators are installed in treatment plants where large quantities of chlorine are used. An evaporator is a hot water heater surrounding a steel tank. Water is usually heated by electricity. Heat in the water is transferred to the liquid chlorine in a inner steel tank. Water bath heaters are used to provide an even distribution of heat around the center tank to eliminate the problem of hot spots on the inner tank. Elimination of hot spots makes the evaporator easier to control and reduces the danger of overheating the chlorine and causing pressurization of chlorine by expansion.

Liquid chlorine containers are connected to the chlorine system through the liquid valve. When the liquid chlorine flowing from the container reaches the evaporator, the liquid chlorine vaporizes. Chlorine gas flows from the evaporator to the gas manifold.

Symptom	Probable Cause
Low Feed Rate and Low Vacuum	Clogged Injector/Ejector
Low Feed Rate and High Vacuum	Clogged Gas Feed Line Closed Cylinder Valve Empty Cylinder
Feed Rate Jumps	Clogged Flow Controller/Needle Valve
Feed Rate Won't "Zero"	Dirty Flow Indicator/Rotameter
Chlorine Gas at Vent	Dirty Pressure Regulating Valve
No Vacuum	No Supply Water Vacuum Leak

respectively). If HTH is used, add 1.5 pounds of HTH per gallon of water to achieve a 1.0-lb./gallon chlorine solution. Using breakpoint chlorination, adjust the stroke on the pump to achieve the desired dosage. Small systems may need to dilute the solution further, since the low flows may require feed rates too low for most feed pumps. Dilution of 5.25% bleach may be easier than HTH solutions.

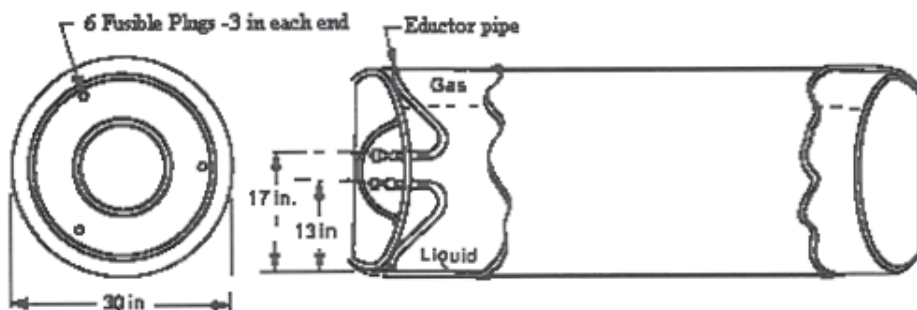


Figure 9.5 - Cross Section of a 1-ton Cylinder

### HYPOCHLORINATION SYSTEMS

A typical hypochlorination system will consist of:

- A solution tank holding bleach or an HTH solution
- A chemical feed pump, usually a diaphragm-type pump
- A tee into the well line as the point of application

The solution tank should hold at least a one-day supply of chlorine solution. If the solution is bleach, it will have between 5.25% and 12% available chlorine (1/3 to 1 lb./gallon

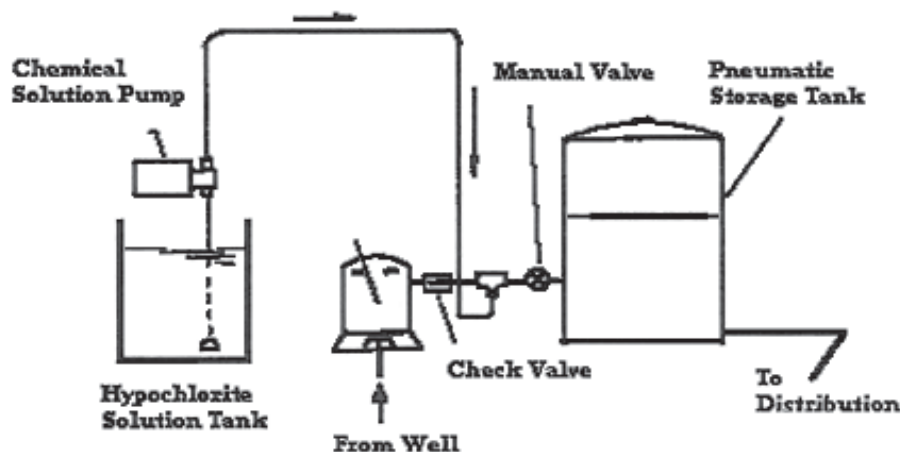


Figure 9.6 - Typical Hypochlorination System

The chemical feed pump consists of a diaphragm driven pump chamber, and two check valves. The check valves, that provide the one-way flow through the pump, can get clogged with lime deposits. This occurs because the HTH that is added to the solution tank is 30-35% lime. The strainer on the pump suction line should be located several inches above the bottom of the solution tank to prevent lime and grit from being drawn into the pump and fouling the check valves.

If the check valves get fouled, the pump will not pump any solution. Flushing the line with clean water or a weak acid, like vinegar, may also correct the problem. In severe cases the valves may have to be disassembled and cleaned. Always make sure the pump is primed before putting it back into service. It may also be advantageous to locate the pump so that it has a positive suction head.

**EMERGENCY RESPONSE PROCEDURES**

When chlorine systems are located in areas where a chlorine release might endanger the general public, the water system is responsible for developing an emergency response program.

The following steps should be followed when a leak poses immediate danger to employees or the public:

1. Evacuate, in an upwind direction, to high ground.
2. Once evacuation is complete, notify emergency medical units of casualties and begin administering First Aid to the injured.
3. Notify local fire and police departments. Include the following information:
  - a) Nature of the accident
  - b) Approximate amount of chlorine that may be released.
  - c) Location of chlorine facility
  - d) Current wind direction
4. Notify County and State health agencies.

**DECHLORINATION**

Dechlorination is the physical or chemical removal of all traces of residual chlorine remaining after the disinfection process and prior to the discharge of the effluent to the receiving waters. This is commonly accomplished by the use of sulfur compounds such as sulfur dioxide, sodium sulfite or sodium metabisulfite.

Dechlorination may be achieved by the following treatment processes:

1. Long detention periods.  
Prolonged detention periods

provide sufficient time for dissipation of residual chlorine.

2. Aeration. Bubbling air through the water with a chlorine residual in the last portion of long narrow chlorine contact basins will remove a chlorine residual.
3. Sunlight. Chlorine may be destroyed by sunlight. This is accomplished by spreading the chlorinated effluent in a thin layer and exposing it to sunlight.
4. Activated carbon. Residual chlorine can be removed from water by adsorption on activated carbon.
5. Chemical reactions. Sulfur Dioxide (SO<sub>2</sub>) is frequently used because it reacts instantaneously with chlorine on approximately a one-to-one basis (1 mg/ l SO<sub>2</sub> will react with and remove 1 mg/l chlorine residual). Other chemicals include sodium sulfite (Na<sub>2</sub>SO<sub>3</sub>), sodium bisulfite (NaHSO<sub>3</sub>), sodium metabisulfite (Na<sub>2</sub>S<sub>2</sub>O<sub>5</sub>), and sodium thiosulfate (Na<sub>2</sub>S<sub>2</sub>O<sub>3</sub>).

Sulfur dioxide is the most popular chemical method used for dechlorination to date. The reason for the popularity of sulfur dioxide is that it uses existing chlorination equipment and makes extensive training of operators unnecessary.

**PROPERTIES**

Sulfur dioxide is a colorless gas with a characteristic pungent odor. SO<sub>2</sub> may be cooled and compressed to a liquid. When the gas is compressed to a liquid, a colorless liquid is formed. As with chlorine, when sulfur dioxide is in a closed container the liquid and gases normally are in equilibrium. The pressure within the container bears a definite relation to the container's ambient temperature. This relationship is very similar to chlorine.

Sulfur dioxide is neither flammable nor explosive in either form, gas or liquid. Dry gaseous sulfur dioxide is not corrosive to most metals; however, in the presence of moisture it forms sulfuric acid (H<sub>2</sub>SO<sub>4</sub>) and is extremely corrosive. Due to this corrosive action, similar materials

<b>Table 9.3</b>	
<b>COMPONENTS OF AN EMERGENCY RESPONSE PLAN</b>	
<b>*</b>	<b>Containment and repair of the leak</b>
<b>*</b>	<b>Notification of other emergency preparedness agencies</b>
<b>*</b>	<b>Evacuation plans for the general public</b>
<b>*</b>	<b>Medical evacuation for casualties</b>

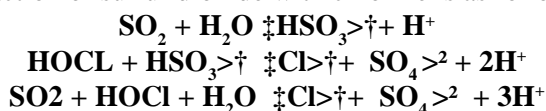
and equipment are used for the storage and application of both sulfur dioxide and chlorine.

The density of sulfur dioxide is very similar to chlorine; so much so, that it is possible to use a chlorine rotameter to measure the flow of sulfur dioxide gas without much difficulty. When using the chlorine rotameter, multiply the chlorine reading by 0.95 to obtain the pounds per day of sulfur dioxide used.

#### CHEMICAL REACTION OF SULFUR DIOXIDE WITH WASTEWATER

The chemical reaction of dechlorination results in the conversion of all active positive chlorine ions to the nonactive negative chloride ions.

The reaction of sulfur dioxide with chlorine is as follows:



The formation of sulfuric acid ( $\text{H}_2\text{SO}_4$ ) and hydrochloric acid (HCl) from this reaction is not harmful because of the small amount of acid produced. The pH of the effluent is not changed significantly unless the alkalinity is very low.

Similar reactions are formed with dichloramine and nitrogen trichloride. If some organic materials are present, the reaction rate may change so that an excess of sulfur dioxide may have to be applied. Unwarranted excess sulfur dioxide dosages should be avoided, not only because it is wasteful, but it may result in dissolved oxygen reduction with a corresponding increase in BOD and a drop in the pH in the effluent.

#### DISINFECTION USING MIXED-OXIDANT SYSTEMS

Mixed-Oxidants refer to onsite brine generators, with day tanks, and automated injection systems, which produce a mixed-oxidant solution for wastewater disinfection. The solution leaves a durable chlorine residual which accomplishes the disinfection of the wastewater.

Mixed-Oxidants utilize a electrolytic cell that produces a liquid stream of very aggressive mixed oxidants that are extremely effective in disinfecting water. The electrolytic cell uses sodium chloride (NaCl), water, and electricity to generate the oxidant solution. Dry salt is loaded into a brine tank and combined with water to form a saturated brine solution. This brine is feed to the electrolytic cell. A liquid mixed-oxidant solution is produced at the anode and cathode and collected in a storage tank. The solution is injected into the water stream at a concentration appropriate for treatment objectives. The chlorine residual can be measured using standard DPD test equipment.

#### SAFETY

As there are no hazardous chemicals used, transported, or stored in the creation of mixed oxidants, they are safer to use than chlorine. Hydrogen gas is produced during the reaction and it should be safely vented from the system. Hazmat training and a Risk Management Plan are not needed.

#### DISINFECTION USING ULTRAVIOLET (UV) SYSTEMS

Just beyond the visible light spectrum there is a band of electromagnetic radiation that we commonly refer to as ultraviolet (UV) light. When ultraviolet radiation is absorbed by the cells of microorganisms it damages the genetic material in such a way that the organisms are no longer able to grow or reproduce, thus ultimately killing them. This ability of UV radiation to disinfect water has been understood for almost a century, but technological difficulties and high energy cost prevented widespread use of UV systems for disinfection. Today, however, with growing concern about the safety aspects of handling chlorine and the possible health effects of chlorination by-products, UV disinfection is gaining in popularity. Technological advances are being made and several manufactures now produce UV disinfection systems for water and wastewater applications. As operating experience with installed systems increases, UV disinfection may become a practical alternative to the use of chlorination in wastewater treatment plants.

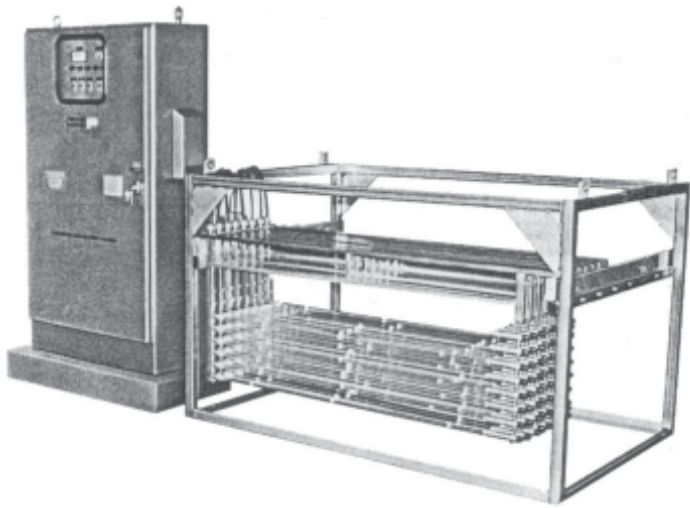
The usual source of the UV radiation for disinfection systems is from low pressure mercury vapor UV lamps which have been made into multi-lamp assemblies, as shown below. A quartz sleeve protects each lamp and each have watertight electrical connections. The lamp assemblies are mounted in a rack (or racks) and these racks are immersed in the flowing water. The racks may be mounted either within an enclosed vessel or in an open channel. Most of the UV installations in New Mexico are of the open channel configuration.

When UV lamps are installed in open channels, they are typically placed either horizontal and parallel to the flow or vertical and perpendicular to the flow. In the horizontal and parallel-to-flow open channel lamp configuration, the lamps are arranged into horizontal modules of evenly spaced lamps. The number of lamps per module establishes the water depth in the channel. For example, 16 lamps could be stacked 3 inches apart to provide disinfection for water flowing through a 48-inch deep open channel.

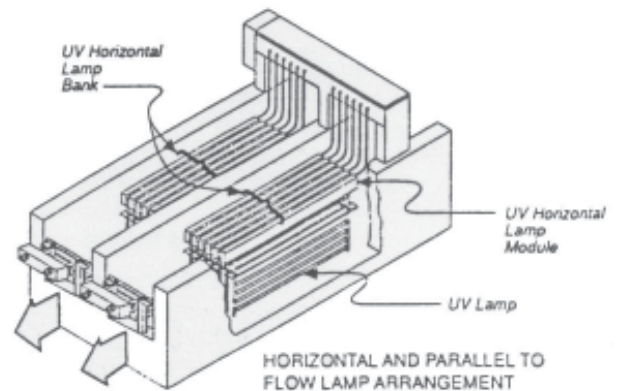
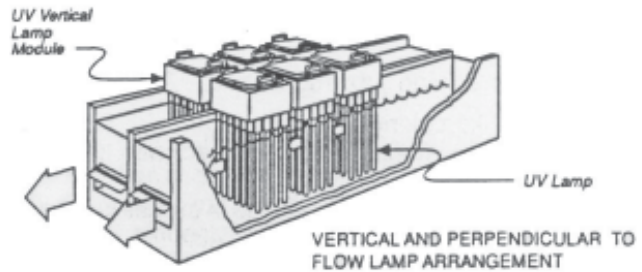
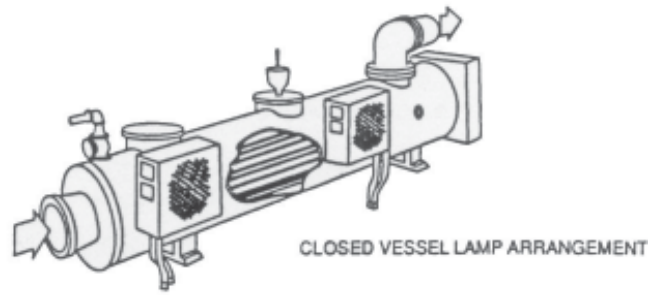
#### SAFETY

The light from a UV lamp can cause serious burns to your eyes and skin. ALWAYS take precautions to protect them.





**Figure 9.7 - UV Lamp Assembly**



**Figure 9.8 - Typical UV Lamp Configurations**

NEVER look into the uncovered parts of the UV chamber without proper protective glasses. Do not plug a UV unit into an electrical outlet or switch a unit on without having the UV lamps properly secured in the UV water chamber and the box closed.

UV lamps contain mercury vapor, a hazardous substance that will be released if a lamp is broken. Handle UV lamps with care and be prepared with the proper equipment to clean up any spills.

### OPERATION

The operation of ultraviolet disinfection systems requires very little operator attention. To prevent short-circuiting and ensure that all microorganisms receive sufficient exposure to the UV radiation, the water level over the lamps must be maintained at the appropriate level. Weirs or automatic control gates can control water levels in channels.

Lamp output declines with use so the operator must monitor the output intensity and replace lamps that no longer meet design standards, as well as any lamps that simply burn out. Lamp intensity monitors can be installed to assist the operator in monitoring the level of light output. Lamp failure indicators connected to the main UV control panel will alert the operator when a lamp burns out and requires replacement.

Care must be taken not to exceed the maximum design turbidity levels and flow velocities when using this type of equipment. Suspended particles will shield microorganisms from the UV light and thus protect it from its destructive effects. Flows should be somewhat turbulent to ensure complete exposure of all organisms to the UV light, but flow velocity must be controlled so that the wastewater is exposed to UV radiation long enough for the desired level of disinfection to occur.

Since ultraviolet rays leave no chemical residual like chlorine does, bacteriological tests must be made frequently to ensure that adequate disinfection is being achieved by the ultraviolet system. In addition, the lack of residual disinfectant means that no protection is provided against recontamination after the treated water has left the disinfection facility. When the treated water is exposed to visible light, the microorganisms can be reactivated. Microorganisms that have not been killed have the ability to heal themselves when exposed to sunlight. The solution to this problem is to design UV systems with a high efficiency for killing microorganisms.

### References

Office of Water Programs, California State University, Sacramento, *Operation of Wastewater Treatment Plants*, Volume 1, 4<sup>th</sup> ed., Chapter 10, Appendix

### Acknowledgments

We wish to thank The Miox Corporation for providing information about Mixed Oxidant systems.

# CHAPTER 10: ACTIVATED SLUDGE

## PROCESS DESCRIPTION

Activated sludge is a suspended growth secondary treatment process that primarily removes dissolved organic solids as well as settleable and non-settleable suspended solids. The activated sludge itself consists of a concentration of microorganisms and sludge particles that are naturally found in raw or settled wastewater. These organisms are *cultivated* in aeration tanks, where they are provided with dissolved oxygen and food from the wastewater. The term “activated” comes from the fact that the particles are teeming with bacteria, fungi, and protozoa.

Like in most other wastewater treatment plants, when wastewater enters an activated sludge treatment facility the preliminary treatment processes remove the coarse or heavy inorganic solids (grit) and other debris, such as rags, and boards. Primary clarifiers (if they are provided) remove much of the floatable and settleable organic material. The activated sludge process can treat either primary clarified wastewater or raw wastewater directly from the preliminary treatment processes. As the wastewater enters the aeration basin, the activated sludge microbes consume the solids in the wastewater. After the aeration basin, the wastewater solids and microorganisms are separated from the water through gravity settling which occurs in a secondary clarifier. The settled solids and microorganisms are pumped back to the front of the aeration basin, while the clarified water flows on to the next component.

## OPERATION OF THE ACTIVATED SLUDGE PROCESS

### PROVIDING CONTROLLABLE INFLUENT FEEDING

The feeding of wastewater to activated sludge systems must be controlled in a manner that ensures even loading to all of the aeration basins in operation. Well-designed flow splitter boxes should be incorporated into the front of the aeration basin and they should be checked periodically to ensure that the flow distribution is split as intended. In some situations, it is desirable to feed wastewater throughout various points in the aeration basin. This is known as step feeding. Step feeding is one method of

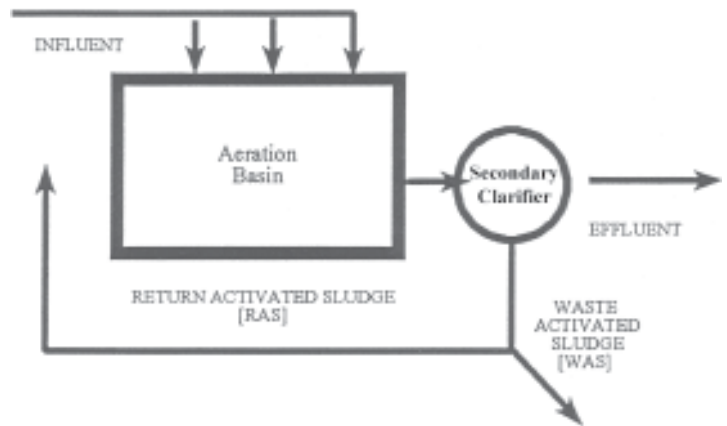


Figure 10.2 - Convention Step Feed Aeration

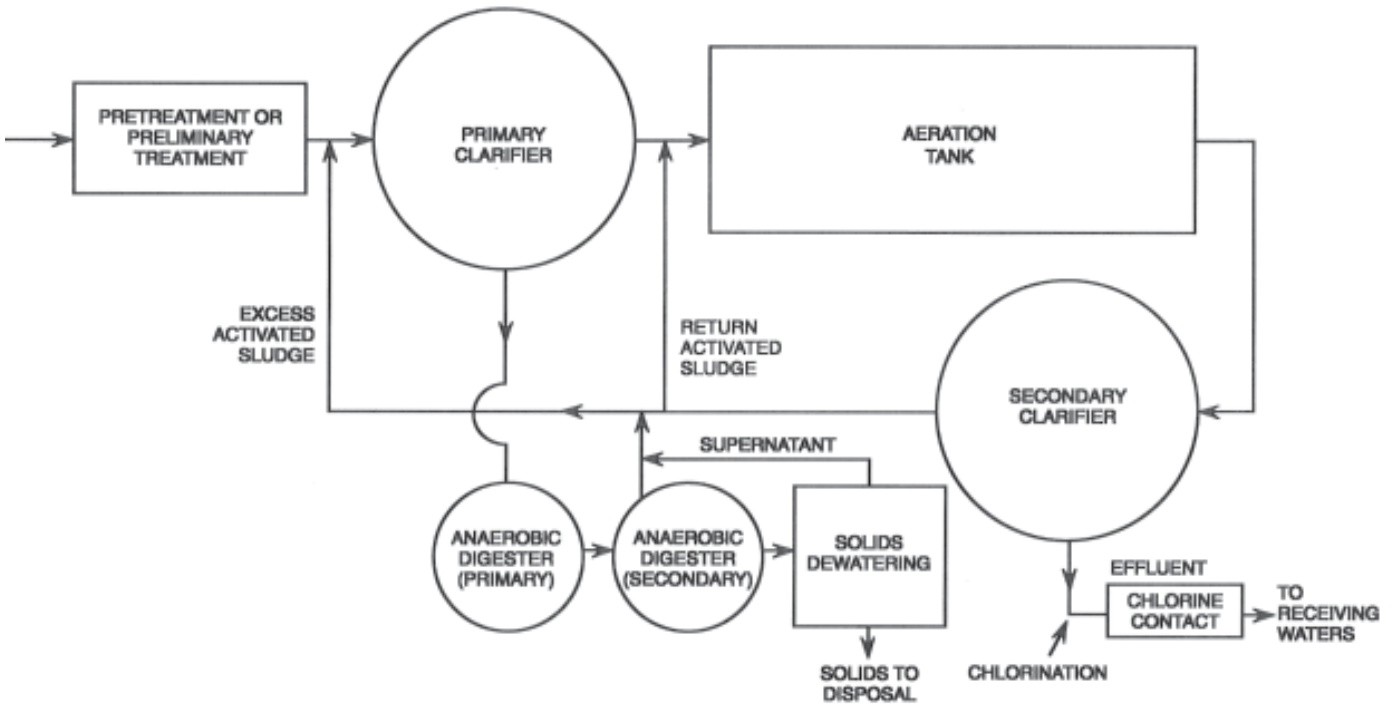


Figure 10.1 - Plant Layout

relieving the high oxygen demand that can occur where the influent flow and RAS enter the aeration basin. However, a downside to step feeding is that some of the dissolved solids in the influent may pass through the aeration basin too rapidly, and show up in the effluent as BOD.

### **MAINTAINING PROPER DISSOLVED OXYGEN AND MIXING LEVELS**

Activated sludge microorganisms need oxygen as they oxidize wastes to obtain energy for growth. Insufficient oxygen will slow down or kill off aerobic organisms, make facultative organisms work less efficiently and ultimately lead to the production of the foul-smelling by-products of anaerobic decomposition. As the mass of organisms in an aeration tank increase in number, the amount of oxygen needed to support them also increases. High concentrations of BOD in the influent or a higher influent flow will increase the activity of the organisms and thus increase the demand for oxygen. Sufficient oxygen must always be maintained in the aeration tank to ensure complete waste stabilization.

This means that the level of oxygen in the aeration tank is also one of the critical controls available to the operator. A minimum dissolved oxygen (D.O.) level of 1.0 mg/L is recommended in the aeration tank for most basic types of activated sludge processes. Maintaining > 1.0 mg/L of D.O. contributes to establishing a favorable environment for the organisms, which produces the desired type of organism and the desired level of activity. If the D.O. in the aeration tank is allowed to drop too low for long periods, undesirable organisms, such as filamentous type bacteria may develop and overtake the process. Conversely, D.O. levels that are allowed to climb too high can cause problems such as floc particles being floated to the surface of the secondary clarifiers. This problem is particularly common during cold weather. For these reasons it is important that the proper dissolved oxygen levels be maintained in the aeration basin. This requires routine monitoring by the system operator using a D.O. meter.

### **CONTROLLING THE RAS PUMPING RATE**

The amount of time that solids spend on the bottom of the secondary clarifier is a function of the RAS pumping rate. The settled microorganisms and solids are in a deteriorating condition as long as they remain in the secondary clarifier. If sludge is allowed to remain in a secondary clarifier too long it will begin to float to the surface of the clarifier due to nitrogen gas released during the biological process of de-nitrification (rising sludge). Monitoring and controlling the depth of the sludge blanket in the secondary clarifier and the concentration of solids in the RAS are important for the proper operation and control of the activated sludge

system. A sludge settleability test, known as a settleometer, can be used to show the rate of sludge settling and compaction. This information is used to determine proper RAS pumping rates. Typically, RAS pumping rates of between 25% and 150% of the influent flow are commonly used.

### **MAINTAINING THE PROPER MIXED LIQUOR CONCENTRATION**

The activated sludge process is a physical/ biological wastewater treatment process that uses microorganisms to separate wastes from water and to facilitate their decomposition. When the microorganisms in activated sludge come into contact with wastewater, they feed and grow on the waste solids in the wastewater. This mixture of wastewater and microorganisms is known as mixed liquor. As the mixed liquor flows into a secondary clarifier, the organism's activity slows and they begin to clump together in a process known as bio-flocculation i.e. the ability of one floc particle to stick to another. Because the velocity of the water in the secondary clarifier is very low, the flocculated clumps of organism settle to the bottom of the clarifier (as sludge), while the clarified water flows over a weir. The settled organisms are constantly pumped back to the front of the aeration basin to treat more waste. This is called return activated sludge, or RAS, pumping.

The clarified effluent is typically disinfected and then discharged from the facility. As the organisms in the aeration basin capture and treat wastes they grow and reproduce and more and more organisms are created. To function efficiently, the mass of organisms (solids concentration) needs a steady balance of food (wastewater solids). If too many organisms are allowed to grow in the aeration basin, there will not be enough food for all of them. If not enough organisms are present in the basin, they will not be able to consume the available food and too much will be lost to the effluent in the form of BOD and TSS.

This balance between the available food (F) and the mass (M) of microorganisms is described as the F:M ratio of the system. The job of an activated sludge wastewater treatment plant operator is to maintain the correct mass of microorganisms for the given food supply. Because the food supply does not typically change very much (that is, the amount of wastewater solids usually stays the same from day to day), operators must adjust the mass of organisms that are allowed to accumulate in the aeration basin. This adjustment is made by removing or *wasting* organisms out of the system. Sludge that is intentionally removed from the activated sludge process is referred to as waste activated sludge, or simply as WAS.

Activated sludge provides treatment through the oxidation and separation of soluble organics and finely divided suspended materials that were not removed by previous treatment. Aerobic organisms accomplish the process in a matter of hours as wastewater flows through the aeration tank and secondary clarifier. The organisms stabilize soluble organic material through partial oxidation resulting in energy for the organisms and by-products, such as carbon dioxide, water, sulfate and nitrate compounds. Finely divided suspended solids such as colloids are trapped during bio-flocculation and thus removed during clarification.

Conversions of dissolved and suspended material into settleable solids as well as oxidation of organic substances (digestion) are the main objectives of the activated sludge process. High rate activated sludge systems tend to treat waste through conversion of the dissolved and settleable solids while low-rate processes rely more upon oxidation of these solids into gasses and other compounds. Oxidation is carried out by chemical processes, such as direct oxidation from the dissolved oxygen in the aeration basin, as well as through biological processes.

Microorganism capture much of the dissolved organic solids in the mixed liquor rapidly (minutes), however, most organisms will require a long time to metabolize the food (hours). The concentration of organisms increases with the waste load and the time spent in the aeration tank. To maintain favorable conditions, the operator will remove the excess organisms (waste sludge) to maintain the required number of workers for effective treatment of the waste. The mass of organisms that the operator maintains is a function of the mixed liquor suspended solids (MLSS) concentration in the aeration basin. By lowering the MLSS concentration (increased wasting), the operator can reduce the mass of organisms in the system. This effectively raises the F:M ratio of the system. By raising the MLSS concentration (reduced wasting), the operator can increase the number of organisms in the system available to provide treatment. This has the effect of lowering the F:M ratio. Again, controlling the rate of sludge wasting from the treatment process is one of the important control factors in the activated sludge system.

#### **Review of Key Activated Sludge Operator Controls:**

- Providing Controllable Influent Feeding
- Maintaining Proper Dissolved Oxygen and Mixing Levels
- Controlling the RAS Pumping Rate
- Maintaining the Proper Mixed Liquor Concentration (controlling the F:M ratio of the system)

The successful operation of an activated sludge process requires a skilled operator that is aware of the many process control factors influencing the treatment and constantly checking these factors. To keep the microorganisms working properly in the activated sludge process the operator must maintain a suitable environment. Toxic substance can kill the organisms in an activated sludge system if allowed to enter the system. Uneven flows can starve or overfeed the microorganism population and the failure to supply enough oxygen may create an unfavorable environment, decreasing the organism activity or even leading to death of the organisms.

### **TYPES OF ACTIVATED SLUDGE TREATMENT PROCESSES**

The activated sludge treatment process can be operated in a variety of different modes. Each of the variations utilizes the basic process of suspended growth in an aeration tank, but new methods of operation are routinely being added to the industry. The three basin modes of operation for the activated sludge process are:

- Convention Activated Sludge
- Extended Aeration Activated Sludge, and
- Contact Stabilization Activated Sludge

The primary difference between these three modes of operation has to do with the length of time that the microorganisms reside in the treatment system. This concept is expressed as the system's solids retention time, or SRT. A system's SRT is calculated as the pounds of MLSS in the system divided by the pounds of suspended solids that enter the system everyday. For example; a system that maintains 1000 lbs. under aeration and receives 100 lbs./day of solids is operating at a SRT of 10 days.

Not surprisingly, there is a relationship between the SRT and the F:M ratio, although they are not exactly the same thing because the F:M ratio actually enumerates the *mass of living microorganisms* divided by the *edible solids* (BOD) that enter the system everyday. Systems that operate at a SRT of around 3.5 to 10.0 days are considered conventional activated sludge. Extended aeration systems generally operate at SRTs of greater than 10 days. Contact Stabilization systems separate the aeration basin into two parts. In the first part, known as the contact basin, microorganisms capture the dissolved and suspended waste solids. In the second zone, which is called the stabilization basin, the microorganisms complete the job of metabolizing the captured food. Contact Stabilization systems typically operated at SRTs below 3.5 days. Because of this, this process is typically used in industrial applications or severely overloaded municipal treatment plants that do not have enough available aeration basin volume.



### CONVENTIONAL ACTIVATED SLUDGE

Conventional activated sludge plants are the most common type in use today. These systems are usually equipped with primary clarification prior to the aeration basin. This method of operation produces a high quality effluent and is able to absorb small shock loads without lowering the effluent quality.

The following ranges describe the typical operating parameters for conventional activated sludge systems:

- Detention time in aeration basin = 4-8 hrs.
- MLSS in aeration basin = 1000-4000 mg/L
- System SRT = 3.5 – 10.0 days
- System F:M Ratio = 0.25 – 0.5 : 1
- RAS pumping rate = 15-75% (of plant influent flow)

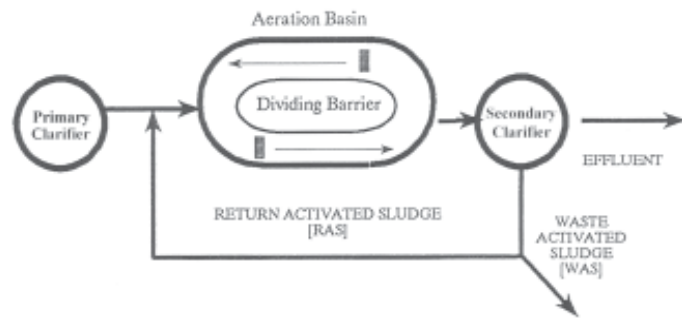


Figure 10.3 - Conventional Aeration

### EXTENDED AERATION ACTIVATED SLUDGE

The extended aeration mode of operation is often used in smaller package-type plants and complete oxidation systems. Extended aeration is typically a very stable activated sludge processes, due to the light loading (low F:M) that these system's operate under. In extended aeration, the low F:M ratios are made possible by the use of larger aeration basins and sludge ages that are commonly greater than 10 days. Although the process is stable and easy to operate, it is common for extended aeration systems to discharge higher effluent suspended solids than found under conventional loadings.

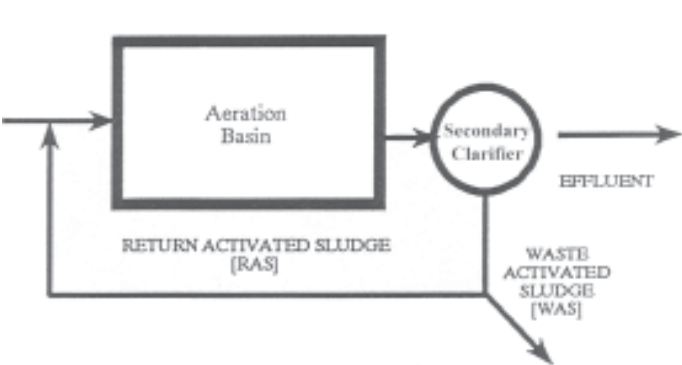


Figure 10.4 - Extended Aeration

Extended aeration processes generally operate within the following ranges:

- Detention time in aeration basin = 12-24 hrs.
- MLSS in aeration basin = 2000-5000 mg/L
- System SRT = > 10 days
- System F:M Ratio = 0.05 – 0.15 : 1
- RAS pumping rate = 50-150% (of plant influent flow)

### CONTACT STABILIZATION

Contact Stabilization is a variation of the conventional activated sludge process that attempts to speed up the capture of the wastewater solids and then rapidly separate the solids from the liquid in a secondary clarifier. The solids stabilization then occurs in a separate tank. The process is best applied where other activated sludge modes would fail due to the short SRTs and detention times.

Contact Stabilization requires a different configuration than the other modes of operation. A small initial aeration basin, known as the contact basin, is where the influent and the microorganisms first come into contact. In this basin, the microbes rapidly capture as much dissolved organic matter and suspended particles as possible. They are then sent to a secondary clarifier to be separated from the liquid. RAS is pumped from the secondary clarifier to a separate stabilization basin, where the microbes are given enough time and oxygen to metabolize much of the waste solids. The flow from the stabilization tank enters the contact tank, thus supplying hungry microbes right at the point where the influent enters the system.

The operating parameters for Contact Stabilization process are as follows:

- Detention time in the contact tank = 0.3-3 hrs.
- Detention time in the stabilization tank = 4-8 hrs.
- MLSS in the contact tank = 1000-3000 mg/L
- MLSS in the stabilization tank = 2-6 times the concentration in the contact tank
- System SRT = < 3.5 days
- System F:M = 0.5 - > 1.0 : 1

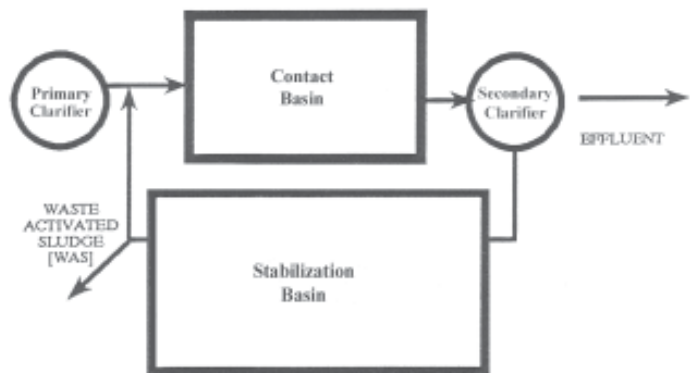


Figure 10.5 - Contact Stabilization

- RAS pumping rate = 25 – 100% (of the influent flow)

### ACTIVATED SLUDGE PROCESS VARIANTS

Numerous types of activated sludge plants have been built using various flow arrangements, tank configurations, and oxygen application equipment. However, all of these variations are essentially modifications of the basic concept of conventional activated sludge. One variation of the activated sludge process that has become very popular recently is known as the sequential batch reactor, or SBR. An SBR essentially combines the aeration basin and the secondary clarifier of a traditional activated sludge system into a single basin. While the system is in aeration mode, air is supplied by the aeration system and influent enters the basin.

Because SBRs operate as a batch process, the level of the basin starts out low and the basin fills over several hours as influent enters. When the filling/ aeration phase is complete, the aeration system shuts off and the basin begins to function as a secondary clarifier. Suspended solids and microorganisms settle to the bottom of the tank and clarified water is left near the surface. Next, a decanting mechanism activates and decants or drains the clarified water from the surface of the basin. This is the period when a SBR system discharges effluent. When the decant is completed, the system begins the cycle of aeration and filling again. The operation of SBRs is discussed in greater detail in Chapter 13: Nitrogen Removal

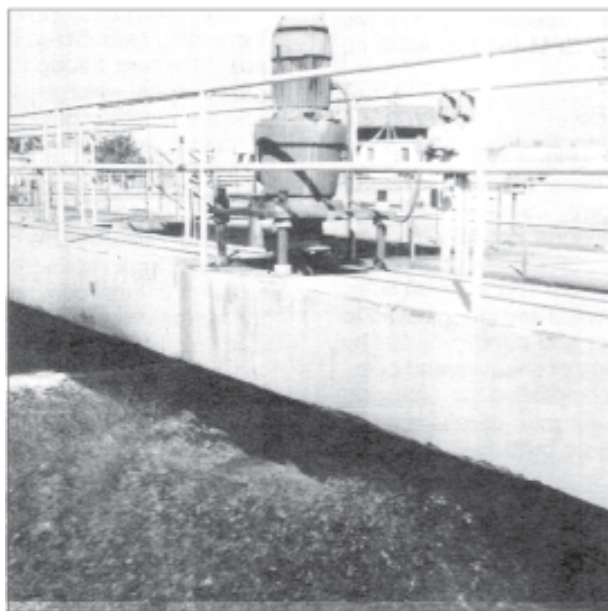
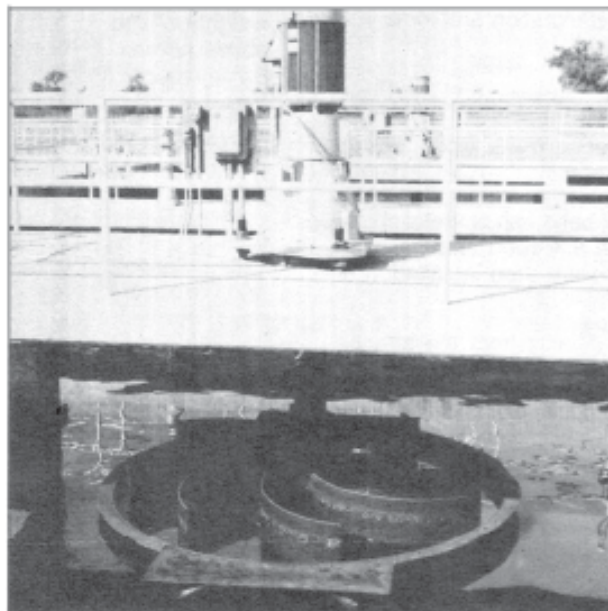
### MECHANICAL COMPONENTS OF ACTIVATED SLUDGE SYSTEMS

#### AERATION SYSTEMS

Aeration serves the dual purpose of providing dissolved oxygen and mixing of the mixed liquor and wastewater in the aeration tank. Two methods are commonly used to disperse oxygen from the air to the microorganisms; Surface Aeration and Diffused Aeration. Both methods are mechanical processes with the major difference being whether the driven unit is located at or in the aeration basin or at a remote location.

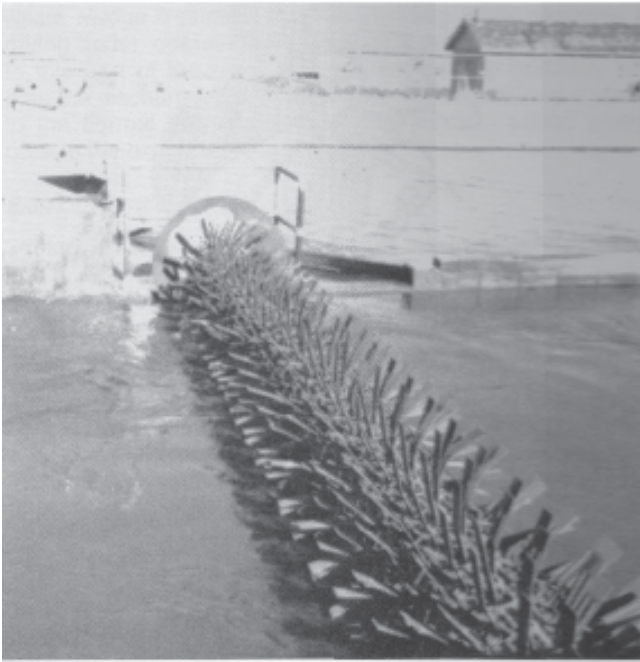
#### Surface Aerators

Surface aerators use a motor-driven rotating impeller or a brush rotor as shown below. Both devices splash the mixed liquor into the atmosphere above the aeration tank. Oxygen transfer to the mixed liquor is achieved by this method of aeration as the mixed liquor passes through the atmosphere. Surface aerators either float or are mounted on supports in or above an aeration basin.



**Figure 10.6 - Bridge Mounted Surface Aerators**

A surface aerator's oxygen transfer efficiency is stated in terms of oxygen transferred per motor horsepower per hour. Typical oxygen transfer efficiencies are about two to three pounds of oxygen per hour per motor horsepower (1.2 to 1.8 kg/hr/kW). The oxygen transfer efficiency increases as the submergence of the aerator is increased. However, power costs also increase because more power is required to move the aerator impeller or agitator through the mixed liquor due to greater submergence and increased load on the drive motor. Surface aerators installed in the aeration tank tend to be lower in installation and maintenance costs. In general, surface aerators are a versatile method of providing aeration, but are less efficient than other forms of aeration in terms of mixing and oxygen transfer per unit of applied power.



**Figure 10.7 - Brush Rotor**

The aspirating aerator is another type of motor-driven mechanical aerator. Aspirating aerators utilize a propeller to provide mixing and an outside source of air is supplied to the aerator, usually from a blower. Aspirating aerators are more efficient and use less horsepower than standard surface aerators because the extra air supply creates turbulence in the immediate area of the rising air bubbles.

### **Diffused Aeration Systems**

Diffused aeration systems are the most common type of aeration system used in the activated sludge process. A diffuser breaks up the air stream from the blowers into fine bubbles in the mixed liquor. The smaller the bubbles, the greater the oxygen transfer, due to the greater surface area of rising air bubbles surrounded by water. Unfortunately, fine bubbles will tend to regroup into larger bubbles while rising unless broken up by suitable mixing energy and turbulence.

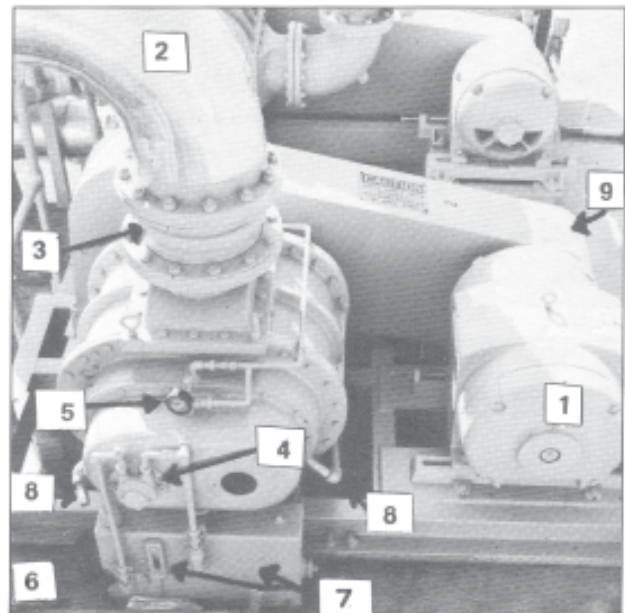
The aeration tank distribution system consists of numerous diffusers attached to the bottom of air Headers. These diffusers are typically located near the bottom of the aeration tank. Diffusers located in this position maximize the contact time of the air bubbles with the mixed liquor. In addition, this location encourages mixing and discourages deposits on the tank bottom. Diffused aeration is a versatile method of aeration that is also used in aerated grit chambers, pre-aeration chambers, aerated flow channels, and RAS wetwells.

### **AERATION BLOWERS**

Mechanical blowers supply the aeration for diffused aeration systems. Blowers are typically either the positive displacement (rotary) or centrifugal (turbine) type and provide air to the various plant processes through a pipe or conduit header system. Usually positive displacement blowers operate at low revolutions per minute (RPM's) and produce less than 20,000 cubic feet per minute (CFM) of air at around 5 – 10 pounds per square inch (PSI). Centrifugal blowers operate at high RPM's and range from 20,000 to 150,000 CFM delivered at 5 – 15 PSI.

### **Positive Displacement Blowers**

Positive displacement blowers consist of a set of apposing lobes that mesh closely past each other, driven by an electric motor. This type of blower provides a constant output of air per revolution for a specific set of lobes. Changing the speed that the unit operates at varies blower output, (the higher the blower RPM's, the greater the air output). Small positive displacement blowers, ranging from 100 to 1,000 CFM, are usually installed to be operated at a fixed volume output. These smaller units are directly driven by electric motors through a direct coupling or through sheaves and belts. If a change in air volume output is required, it is accomplished by changing the motor to one with a higher or lower operating RPM or by changing sheaves to increase or decrease the blower lobe rotation. This type of smaller



1. motor
2. air line (discharge)
3. flexible coupling
4. lube oil pump
5. oil pressure gage
6. oil filter
7. oil level indicator and reservoir
8. oil seal air vents
9. belt guard

**Figure 10.8 - Positive Displacement Blower**



units is commonly used with package plants, pond aeration, small aerobic digesters, gas mixing in anaerobic digesters and gas storage compressors.

Large positive displacement blowers (2,000 to 20,000 CFM) are sometimes driven by internal combustion engines or variable-speed electric motors in order to change blower volume outputs as required for the aeration system. Inlet and outlet piping is connected to the blower through flexible couplings to keep vibrations to a minimum and to allow for heat expansion. When air is compressed, heat is generated, thus increasing the discharge temperature as much as 100°F or more. A check valve follows next which prevents the blower from operating in reverse should other blowers in the same system be operating while this blower is off.

The discharge line from the blower is equipped with an air relief valve, which protects the blower from excessive backpressure and overload. Air relief valves are adjusted by weights or springs to open when air pressure exceeds a point above normal operating, around 6.0 to 10.0 psi. An air discharge silencer is also installed to provide noise reduction. Ear protective devices should be worn when working near noisy blowers.

The impellers are machined on all exterior surfaces for operating at close tolerances. They are also statically and dynamically balanced. Impeller shafts are made of machined steel and are securely fastened to the impellers. Timing gears accurately position the impellers. For large positive displacement blowers, a lube oil pump, driven from one of the impeller shafts, maintains lubrication to the gears and bearings.

An oil pressure gage monitors the system oil pressure. An oil filter is located in the oil sump to ensure that the oil is free from foreign materials. The proper oil level must be maintained in the gear housing so that gears and bearings will receive splash lubrication in case of lube oil pump failure.

Air vents are located between the seals and the impeller chamber to relieve excessive pressure on the seals. Years of experience has come to indicate that the life of positive displacement blowers can be greatly extended by operating them on synthetic oil, rather than petroleum based oil. Synthetic oil does a better job of resisting viscosity breakdown at the high operating temperatures that these blowers run under. The higher cost of synthetic oils is easily recovered through extended blower life.

### **Turbine Blowers**

A Turbine blower consists of a motor connected to a set of turbine blades on a steel shaft. Air output of the blower is controlled by a throttling butterfly type valve, which is located on the intake side of the blower, or by regulating the RPM at which the blower operates. The throttling valve or blower RPM may be controlled manually by operating personnel or by plant instrumentation based on either dissolved oxygen levels in the aeration tanks or the plant influent flows.

The blower itself consists of a set of turbine blades, shaft and bearings, the blower housing, a blower to drive unit coupling and an electric motor or internal combustion engine to drive the unit. Air enters the blower housing through an inlet pipe and is picked up by the whirling turbine blades where it is compressed slightly and then discharged out the outlet manifold piping. Air discharge lines are connected to the blower through flexible couplings in order to keep vibration to a minimum and to allow for heat expansion. The air discharge line is usually equipped with a manually or mechanically operated butterfly valve. Air bypass and discharge valves are usually electrically or pneumatically operated. To dampen overall vibrations, turbine blowers are often mounted on an isolation pad that incorporates shock-dampening materials.

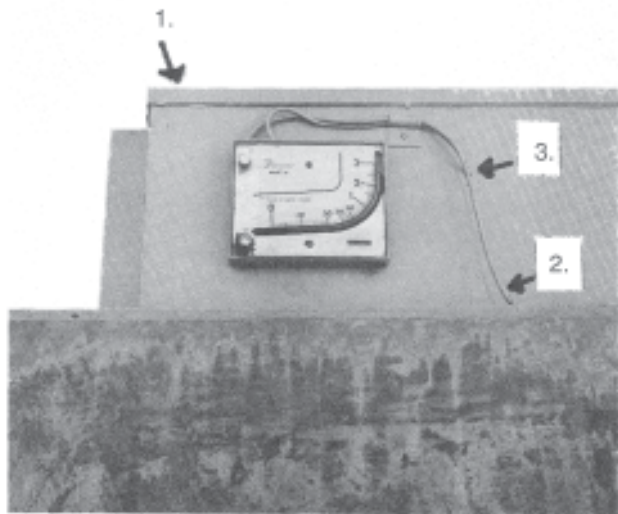
The turbine shaft is supported on shaft bearing stands, which contains a thrust bearing (outboard) and journal (inboard) bearing. Turbine blower bearings are lubricated through a variety of methods, which include grease cups, oil reservoirs and oil pumps. Due to the very high speeds at which these blowers operate and the resultant high lubricant temperatures, bearing over-temperature sensors are often installed that will shut the blower off if the bearing temperature rises above a preset-point.

### **Air Flow Meter**

Air-metering devices should be located in a straight section of the blower discharge manifold. The device consists of an orifice plate inserted between two specially made pipe flanges. The orifice plate is made of stainless steel with a precision hole cut through the center. The diameter of the hole will vary according to the flow rates to be measured. The plate is made of 1/8-inch thick material and is slightly larger than the inside diameter of the pipe. A rectangular handle is attached to the plate. The plate is installed between the flanges, blocking the pipeline except for the hole in the center of the plate. One side is beveled, leaving a sharp edge on the opposite side. The handle of the orifice plate will have numbers stamped into it giving the orifice size. These numbers on the handle are stamped on the same side as the sharp edge of the orifice opening. When viewing the plate to read the numbers, the blower should

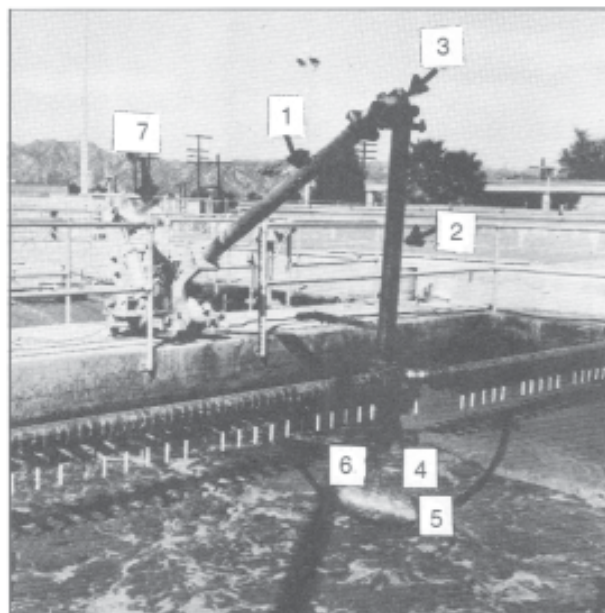


1. Filter chamber
2. Filter chamber inlet pressure tube to manometer or water column gage
3. Filter chamber outlet pressure tube to manometer or water column gage



Manometer on a filter chamber (not a U-tube manometer) reading inches of pressure difference

**Figure 10.9 - Air Metering Device**



1. upper riser pipe
2. lower riser pipe
3. pivot elbow
4. leveling tee
5. horizontal air header
6. air blowoff leg
7. hoist

**Figure 10.10 - Swing Header**

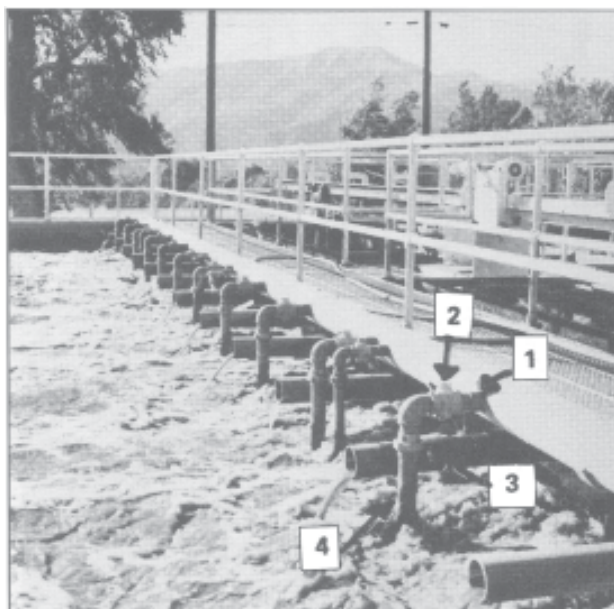
be behind you. THE SHARP EDGE OF THE ORIFICE PLATE AND THE NUMBERS MUST BE ON THE SIDE TOWARD THE BLOWER FOR THE METER TO OPERATE PROPERLY. On top of each pipe flange holding the orifice plate will be a tapped hole. Tubing connected to the hole leads to the instrument that indicates the rate of airflow. There may be more than one orifice plate and metering device in the distribution system to monitor the air to the various plant processes.

The fixed header is a pipe with a distribution system connector fitting, a valve, a union, a riser pipe, horizontal air headers, and header support “feet”. These headers are generally not provided with adjustable leveling devices, but rely on the fixed leveling afforded by the feet attached

Condensate traps are located at each meter and at the lowest points of the distribution header. These condensate traps allow moisture to be collected and removed from the system.

### Air Headers

Air headers are located in or along the aeration tank and are connected to the air distribution system from which they supply air to the diffusers. The two most common types of air headers are the swing header and the fixed header. The swing header is a pipe with a distribution system connector fitting, a valve, a double pivot upper swing joint, upper and lower riser pipes, pivot elbow, leveling tee, and horizontal air headers. An air blow off leg, as an extension to the lower tee connection, is fabricated with multiple alignment flanges, gaskets, and jack screws for leveling of the header. The swing joint and pivot elbow allow the header to be raised from the aeration basin with a hoist so the header or diffusers may be serviced.



1. distribution system connector fitting
2. header valve—regulating and isolation
3. union
4. riser pipe

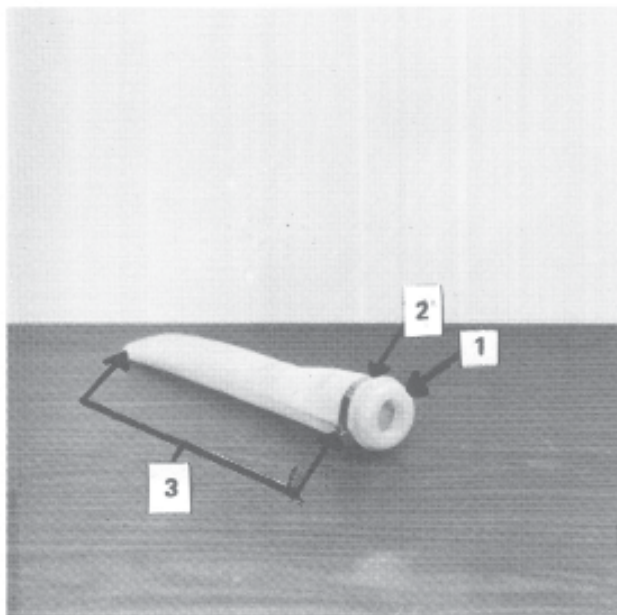
**Figure 10.11 - Fixed Header**

to the bottom of the horizontal air headers. The fixed header is commonly found in package plants, channel aeration, and grit chamber aeration.

Butterfly type header valves are used to adjust the airflow to the header assembly and to block the airflow to the assembly when servicing the header or diffusers. Headers are designed for a maximum airflow in cubic feet per minute at a total maximum head loss measured in inches of water.

### **Diffusers**

Three types of diffusers are commonly in use today, Fine bubble diffusers, medium bubble diffusers and coarse bubble diffusers. Plate and tube diffusers and dome type diffusers are classified as fine bubble diffusers. Medium bubble diffusers are commonly porous nylon or Dacron socks, or fiberglass or saran-wrapped tubes. Fine bubble diffusers can be easily clogged because of the very fine holes that are required to produce small air bubbles. They may clog either from the inside (caused by dirty air), or from the outside due to biological growths. These diffusers typically have an oxygen transfer efficiency of around 6-15%.



Nylon sock

1. sock to support frame and threaded head r mount
2. sock to support frame clamp
3. porous sock (air comes out between ends indicated by arrows)

**Figure 10.12 - Medium Bubble Diffuser**

Coarse bubble diffusers are generally made of plastic and are of various shapes and sizes. These types of diffusers have lower oxygen transfer efficiencies (about 4-8 percent) and are lower in cost. Although course bubble diffusers are relatively maintenance free, if the plant entrance works

does not do a good job of removing rags from the influent flow, the diffusers may become clogged with attached rags. This is not a failing of the diffuser type, but rather a failing of the entrance works.

In most applications, numerous diffusers are mounted to a horizontal air header. The required mixing and oxygen transfer of a specific aeration tank determines the number of diffusers mounted to the air header.

### **Air Filters**

Air filters remove dust and dirt from air before it is drawn into an aeration blower. Clean air is essential for the protection of:

1. Blowers
  - a. Large objects entering the turbines or lobes may cause severe damage.
  - b. Deposits on the turbines or lobes reduce clearances and cause excessive wear and vibration problems.
2. Process Systems
  - a. Clean air is required to protect downstream equipment, such as the diffusers.
  - b. Clean air prevents fouling of airflow measuring equipment, process piping and flow control valves.

The filters may be constructed of a fiber mesh or metal mesh material that is sandwiched between a screen material and encased in a frame. The filter frames are then installed in a filter chamber. Other types of filters include bag, oil coated, traveling screens, and electrostatic precipitators. Process air is usually drawn directly from the atmosphere. Some treatment plants have pretreatment and primary treatment process tanks covered for odor control. In some plants of this type, the odorous air is drawn from under these covered tanks and used as process air.

### **SAFETY**

Safety Considerations for Aeration Tanks and Clarifiers  
Whenever you must work around aeration tanks and clarifiers, use safe procedures and exercise extreme caution at all times.

1. Wear safety shoes with steel toes, shanks, and soles that retard slipping. Cork-inserted composition soles provide the best traction for all around use.
2. Wear a Coast Guard Approved life jacket when working around aeration tanks where there are no guardrails to protect you. Because of the volume in the aeration tank that is occupied by air bubbles, a person without a floatation device is not buoyant enough to float or swim in an aeration basin. Even with a life preserver, you may become drawn below

the surface by the current. Because of this, the air supply must be turned off immediately if someone falls in.

3. Slippery algal growths should be scrubbed and washed away whenever they appear on walkways.
4. Keep the area clear of spilled oil or grease.
5. Do not leave tools, equipment, and materials where they could create a safety hazard.
6. Adequate lighting should be permanently installed for night work, especially for use during emergencies.
7. Ice conditions in winter may require spiked shoes and icy areas should be sanded if ice cannot be thawed away with wash water.
8. Remove only sections of guardrails necessary for the immediate job. Removed sections should be properly stored out of the way and secured against falling. The area should be properly roped off or barricaded to prevent the entry and possible injury of personnel.

#### **SURFACE AERATOR SAFETY CONSIDERATIONS**

If maintenance or repair is required on the aerator, the aerator must be shut down and the MAIN POWER BREAKER MUST BE OPENED (SHUT OFF), LOCKED OUT, AND PROPERLY TAGGED. The lockout should be accomplished with a padlock and you should keep the key in your pocket. Tag the breaker with a lockout tag and note the date the aerator was locked out, the reason for the lockout, and the name of the person who locked out the aerator.

If an electrical problem exists with the aerator, Only Qualified Electricians should be allowed to troubleshoot and repair the problem. Serious damage has occurred to equipment and to unqualified people who were just trying to fix it.

Surface aerators are located directly over the aeration basin and caution is required when working in that area. If the basin is empty, a 15 to 40 foot fall could be fatal. The worker should be protected by a fall arrest system that will safely suspend the worker in case of a fall. Requirements for fall arrest systems can be found in the section on safety. When the basin is full of water you could drown if you fell into the water. Whenever any work must be done on a surface aerator in a basin, the work should be done by two persons wearing approved flotation devices or fall arrest systems depending on the status (full or empty) of the basin.

#### **MECHANICAL BLOWER SAFETY CONSIDERATIONS**

When cleaning the air filters, shut down and secure the blower system you will be working on, even if it means shutting down the entire blower system. A 30-60 minute shutdown will not adversely affect the activated sludge process. Don't take chances by trying to operate the blower

system while cleaning the filters if you can't bypass the filters being cleaned. If the blowers are operating while trying to remove or install filters, foreign material can be drawn into the filter chamber and ultimately into the blower unit where extensive damage to the blower will result.

Wear gloves when removing and installing filters to protect your hands from cuts. Safety goggles should be worn when cleaning the filters to keep foreign matter out of your eyes. An approved dust and mist respirator should be used to prevent ingestion and or inhalation of filter dust. Persons should not be assigned to tasks requiring use of respirators unless it has been determined that they are physically able to perform the work and use the equipment. Check with your local safety regulatory agency for specific physical and training requirements.

Before starting any blower, be sure all inlet and discharge valves are open throughout the system. Remove all foreign matter that might enter the blower. All personnel must be clear of the blower before starting. Always wear appropriate hearing protection when working near an operating blower. Hearing protectors must attenuate (reduce) your noise exposure at least to an eight-hour time average not to exceed 90 decibels. When a blower must be shut down for maintenance or repair be sure the main power breaker is Opened (Shut Off), Locked Out, and Properly Tagged. If an electrical problem exists with the blower drive motor, only Qualified and Authorized Electricians should be allowed to troubleshoot and repair the problem.

#### **AIR DISTRIBUTION SYSTEM SAFETY CONSIDERATIONS**

The aeration tank areas where the distribution piping is located are hazardous and caution is required when working on distribution systems. If the aeration tank or channel is empty a 10-20 foot fall could be fatal. The worker should be protected by a fall arrest system that will safely suspend the worker in case of a fall. When the aeration tank or channel is full of water you could drown if you fell into the water. When working on air distribution system piping near an aeration tank or channel, have at least two operators present and have everyone wear approved flotation devices or fall arrest systems depending on the status (full or empty) of the basin.

Air headers are located in areas with hazards similar to those encountered when working on the air distribution system exercise care to avoid falling into empty tanks or tanks full of wastewater.



Caution should be used when operating an electric or manual hoist.

1. Never lift or lower a header pipe until you are sure the hoist is firmly and properly anchored and that its capacity is sufficient. If it is not, the hoist may jackknife into the tank when lifting or lowering starts and you could be knocked into the tank.
2. Never lift or lower a header pipe until the double pivot upper swing joint locking pin is removed. Lifting or lowering the header with the locking pin in place will cause the pivot to crack.
3. Make sure that the hoist support foot transmits the load to the concrete tank structure and not to the removable decking. This decking is designed to support only a few hundred pounds of weight.
4. Use the double pivot upper swing joint locking pin to secure the header assembly above the walkway. Failure to do this will result in the header assembly lowering itself into the tank if the hoist hydraulic system fails.

## **ACTIVATED SLUDGE PROCESS CONTROL**

The activated sludge wastewater treatment process is capable of producing an excellent effluent quality when properly designed, constructed and operated. BOD and TSS removal rates in excess of 99% are not unusual. There are three areas of major concern for the operator of an activated sludge plant.

1. The characteristics of the influent that is going to the aeration basin.
2. The environment in the aeration basin that must be maintained to ensure good treatment.
3. The operating conditions within the secondary clarifier, which affects how well solids separation will occur.

As you may suspect, all three of these areas are closely related and influence each other.

### **INFLUENT CHARACTERISTICS**

#### **Organic and Hydraulic Loading**

In most municipal activated sludge wastewater treatment facilities, the influent flow and BOD/TSS concentration does not vary by more than 10% from day to day. This results in a relatively stable (and predictable) loading being applied to the aeration basin. However, for some facilities, the flow or the BOD/TSS concentration (or both) varies greatly. One example of where this might occur is a small package treatment plant that treats the discharge from a school. In this situation, the influent flow only occurs from 8:00 AM until 4:00 PM and stops entirely on weekends (and for three months during the summer). In another

example, a municipality may have a tremendous loading increase (both flow and BOD/TSS) for several days a week while a local industry, such as a food processing plant, is in operation. Because a large part of the operator's job is to maintain the correct mass of microorganisms to meet the incoming food, operating in a situation where the influent loading is constantly changing greatly complicates matters. Therefore, all changes to the influent loading must be understood and considered by the operator of an activated sludge system. This requires accurate influent flow measurements and at least periodic influent BOD and TSS sampling and analysis.

#### **The Effect of Toxic Substances**

Toxins pose another consideration for the operator of an activated sludge plant. If the influent that is being fed to the organisms in the aeration basin cannot be metabolized or if it is toxic, the organisms will die off and the process will fail. An example of this situation is when recreational vehicles (RVs) are allowed to discharge large amounts of holding tank waste to a treatment plant. Chemicals, such as formaldehyde, are often used to stabilize RV holding tanks. Formaldehyde is highly toxic to activated sludge microbes, so even a single RV's discharge can kill-off a small package plant. Please be aware that microbe friendly, biodegradable alternatives are available as a replacement for formaldehyde based products.

### **AERATION BASIN ENVIRONMENT**

#### **Food and Dissolved Oxygen**

The aeration basin environment itself can best be described as a zoo of microorganism, each competing for oxygen, food and the ability to reproduce. It is the job of the activated sludge system operator to provide this zoo of organisms with the correct amount of oxygen, mixing and food. The food is of course supplied in the form of dissolved and suspended solids in the wastewater itself.

The level of oxygen in the aeration basin can be controlled (to an extent), although many older systems are simply run all-out to provided as much aeration as possible, even though it may not be enough. A dissolved oxygen level of >1.0 mg/L is desirable, but it is important to understand that the required level of dissolved oxygen is actually related to the F:M ratio that the system is operating under. This is because the microorganisms in the basin primarily consume the oxygen as they capture and metabolize the dissolved and particulate waste solids.

If the BOD loading increases, the amount of dissolved oxygen that is needed in order for the microbes to capture and stabilize the waste will increase. If the BOD loading decreases, the oxygen demand for the system will go down. This phenomenon can be observed every day in an aeration



basin during peak loading (usually around 9:00 – 10:00 AM). At this time, the oxygen demand in the aeration basin will be at its highest, because a large amount of food is entering the basin and the microbes are utilizing lots of dissolved oxygen as they capture and begin to digest the food. In the middle of the night, when the loading is low, the demand for dissolved oxygen will go down. You can actually see this effect when using a dissolved oxygen meter to measure the D.O. levels in the aeration basin. Some systems run at less than 1.0 mg/L of D.O. and yet operate well because they are still operating within an acceptable F:M range. Some highly loaded systems need much more than 1.0 mg/L of D.O. just to get by. Remember that it is easier to dissolve oxygen into cold water than into warm water. Therefore cold weather increases aeration system performance, although the microorganism activity is reduced.

### **Adequate Mixing**

Thorough mixing of the contents of the aeration basin is also very important. No settling should occur in the basin itself. Solids settling can be evaluated using a stick or a sludge blanket indicator by probing around the bottom of the aeration basin. Solids that settle to the bottom of the basin will rapidly become septic and cause a variety of problems, such as increased oxygen demand, lower aeration basin detention times and excess growth of the types of filamentous bacteria that are associated with septic conditions.

However, excessive mixing also has a down side. If the turbulence in the aeration basin is too high, a phenomenon known as floc shear will occur. Floc shear is characterized by floc particles that are broken up. In the secondary clarifier, this leads to increased effluent TSS concentrations. Floc shear can be diagnosed using a microscope. Under magnification, the broken floc particles are evident. If a microscope is not available, look for signs of excessive turbulence in the aeration basin whenever the effluent TSS seems unusually high without another obvious cause.

### **Maintaining the Correct F:M**

In order to achieve good treatment and a stable system, the mass of microorganisms must be maintained at the correct level needed to consume virtually all of the food that enters the system each day. One way to think about this situation is to consider how you might go about feeding your pet dog everyday. If you have a dog that weighs 100 lbs., it probably eats around 2 – 4 lbs. of dog food each day. If we describe your dog's diet in terms of a Food to Mass ratio, we would say that the F:M of your dog ranges from 0.02 – 0.04 to 1.00. Activated sludge wastewater treatment plants can be considered in the same fashion, except that they can be operated at a much higher F:M than your dog.

Extended aeration activated sludge plants are operated at an F:M ratio of 0.05 – 0.15 to 1.00. In other words, if the mass of microorganisms in the aeration basin weighs 100 lbs., it can eat between 5 and 15 lbs. per day. Conventional activated sludge treatment plants operate at even higher F:M ratios. Conventional systems run at an F:M of between 0.25 and 0.5 to 1.00. This would be like a 100 lb. dog eating between 25 and 50 lbs. of food each day. Some Contact Stabilization processes operate even higher, with 1.00 to 1.00 ratios and beyond. This would be like a 100 lb. dog eating 100 lbs. of dog food everyday!

What is a strange concept to many people when considering this analogy is that, it is not the amount of food that an activated sludge wastewater operator is in control of, it is the size of the dog. By increasing or decreasing the overall mass of MLSS, operators actually change the number of microorganisms available to consume the daily load of waste solids. Although the amount of loading (food) varies a little each day, overall, it stays close to the same. However, operators effectively control the size of the dog by increasing or decreasing the mass of microorganisms (increasing or decreasing the daily WAS flow) in order to meet the loading.

The key to stabilizing the activated sludge process lies in doing a good job of maintaining the right mass of microorganisms to fully consume the daily loading, all of the time. To accomplish this, the amount wasted from the system each day needs to be close to the amount that enters the system each day, with some allowance for solids that are destroyed through digestion while in the aeration basin or lost to the effluent. Typically, this means that the number of pounds of solids wasted from a system each day must be around 50 – 70% of the total number of pounds of solids that enter the system each day. (Remember that the difference between the influent loading and the required WAS lbs./day is made up through digestion in the aeration basin and solids lost to the effluent).

### **Determining a Treatment Plant's F:M**

To actually calculate the F:M ratio of a activated sludge wastewater treatment plant, we need to know how much food is entering the aeration basin each day and how many pounds of microorganisms are in the aeration basin available to eat the food. The amount of food is determined by calculating the BOD loading in terms of pounds per day of influent entering the aeration basin. The mass of microorganisms is calculated based on the mass, in pounds, of mixed liquor volatile suspended solids (MLVSS) in the aeration basin. The volatile suspended solids are used in this calculation because it is assumed the all of the volatile solids are comprised of living microorganisms and the non-volatile solids are inert matter that does not contribute to metabolizing the waste solids.

This is an example of the F:M calculation for an extended aeration activated sludge wastewater treatment plant:

$\frac{\text{(FOOD) } 160 \text{ lbs./day BOD into Aeration Basin}}{\text{(MASS) } 2000 \text{ lbs. MLVSS in Aeration Basin}} = 0.08 \text{ F:M}$
---

Whenever the conditions within an activated sludge treatment plant must be assessed, IT IS THE F:M RATIO THAT MUST FIRST BE DETERMINED in order to understand what mode of operation the system is in and determine how well it is functioning. Only after the F:M is understood can the other operating factors be assessed.

In the absence of the laboratory data that is necessary to calculate the F:M, some keen observation can be used to understand whether a system is running at a high F:M, low F:M or just right. For instance, if a clear, high quality effluent is being produced and the aeration basin has a small amount of crisp white foam on the surface and the mixed liquor is a chocolate brown color, the F:M is close to ideal and the system is running very well. Operations should continue in the same manner.

If the effluent quality is cloudy, large floc particles are exiting over the secondary clarifier weirs (straggler floc), the aeration basin has a lot of frothy white or gray foam on it, the mixed liquor has a light brown or tan color and the effluent BOD and TSS are elevated, the system is most likely running at a high F:M, such as an overloaded plant or a plant in start-up conditions. In this case, the operator should allow the system to build up a larger mass of MLSS by reducing wasting.

If there is a thick, dark foam on the aeration basin surface, the mixed liquor is dark brown or even a dark reddish color, sludge is floating to the surface of the secondary clarifier and very small floc particles that are about the size of the head of a pin (pin floc) are observed in the effluent, the system is operating at too low of a F:M. In this case, the operator should increase wasting.

## **SECONDARY CLARIFIER CONDITIONS**

### **Clarifier Design Features**

The design of the secondary clarifier(s) of an activated sludge wastewater treatment plant can have a strong effect on how the system will perform as a whole. Desirable features that should be included in activated sludge secondary clarifiers include:

- Good inlet flow control structures that allow the operator to carefully regulate the hydraulic loading to the clarifier.
- Energy dissipating baffles at the mixed liquor inlet area that quickly slow the mixed liquor and direct it downward. Some provision for gentle mixing during entry into the clarifier is helpful at starting

### **Figure 10.13 - Calculating F:M**

bio-flocculation. Some old and most new clarifier designs incorporate these features.

- Short-circuiting should be eliminated. Short-circuiting occurs when a portion of the mixed liquor that enters the clarifier is allowed to move rapidly toward the weirs and out of the clarifier. There are many causes of short-circuiting, such as thermal density-currents and poor baffle design, however, the most common cause is uneven weirs that draw the clarifier supernatant over one area at a much higher rate than other areas of the weir.
- Secondary clarifiers should be deep enough to allow some process upsets without the loss of the sludge blanket. For most treatment plants, this means a clarifier depth of greater than 12 feet.
- A detention time of between 2 and 4 hours should be provided for the highest flow (peak flow) that the clarifier will be subjected to. This is a function of the clarifier's volume.
- A surface-loading rate of between 300 to 1,200 gallons per day per square foot. This is a function of the clarifier's hydraulic loading and surface area.
- Effective sludge removal for the entire bottom of the secondary clarifier. This typically includes a sludge scraper mechanism that sweeps the bottom of the clarifier and moves settled sludge toward the RAS pump inlet box.
- Accurate control of the RAS pumping rate. This is critical for ensuring that the sludge is removed at the proper rate. Some form of RAS pump control and flow measurement should be provided.
- Drains should be provided for each clarifier so that they can be taken down for service and inspection.

Although these features are all desirable, they are not always included in every secondary clarifier. This is in part because the cost of construction must be considered when clarifiers are designed and built.

### **RAS Flow Control**

The sludge blanket depth in an activated sludge secondary clarifier should be determined at least twice a day by actually measuring the blanket at about the middle of the clarifier bridge. Several methods for measuring sludge blanket levels are available, such as the core sampler and the infrared detector. The method used is less important than ensuring that the measurements are performed in a consistent manner.

At first glance, determining the proper RAS flow rate would appear to be simple. In general, the RAS pumps should be run just fast enough to maintain the smallest sludge blanket in the clarifier possible. However, it must be remembered that the flow into the clarifier is changing all throughout the day. This means that the loading to the clarifier, and thus the sludge accumulating in the clarifier is changing all throughout the day. The typical 24-hour cycle of peak and low flows experienced by most treatment facilities will generally cause the sludge blanket in a secondary clarifier to accumulate throughout the day and drop throughout the night.

To complicate matters, the “settleability” of the sludge is not always the same. Some sludges settle rapidly and compact at the bottom of the clarifier, while others settle slowly and compact only a little. Simply increasing the RAS pumping rate for a sludge that will not settle will not bring the sludge blanket down (although this is the typical response by operators), because all of the sludge that is pumped out of the clarifier returns back to it. In fact, increasing the RAS pumping rate above the allowable range often results in clarifier washout, because at some point, the hydraulic loading rate of the clarifier is exceeded.

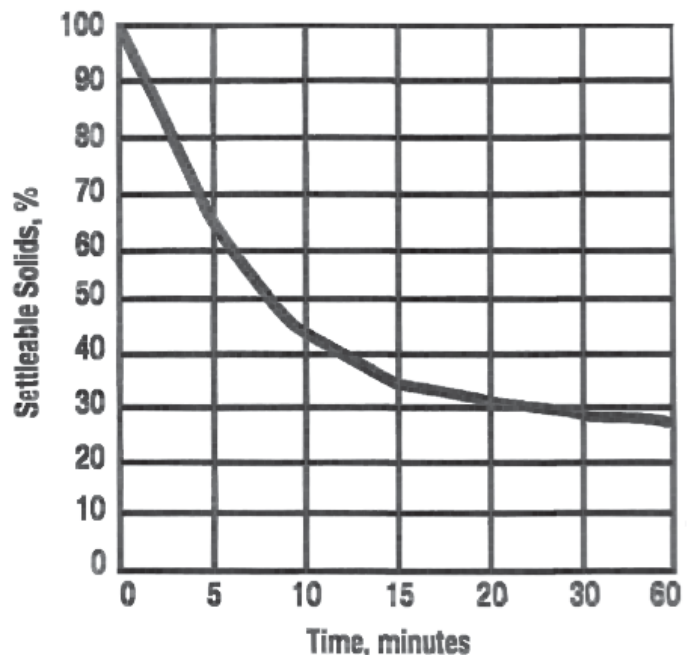
If a sludge settles well but is not removed from the secondary clarifier fast enough, biological activity will continue in the sludge, resulting in the formation of nitrogen gas bubbles. These nitrogen gas bubbles will cause particles and even clumps of sludge to float to the surface of the secondary clarifier (this process is known as denitrification). Whenever this type of “rising sludge” is observed in an activated sludge secondary clarifier, it is a sign that RAS pumping rate should be increased. At this point, it should be clear that there is no magic setting for the RAS pumping rate, but rather a series of checks and observations that operators must continually make to ensure that the pumping rate is correct for the given conditions.

### Settleometer Test

To better understand how sludge will settle in the secondary clarifier, operators use a test known as the settleometer. The settleometer test is a method of simulating the settling of activated sludge in a secondary clarifier. The test is performed on a sample of mixed liquor taken from the end of the aeration basin, right before it enters the secondary clarifier. The sample, which is usually 1 – 2 liters, is placed into a special settleometer container, which is essentially a large, clear graduated beaker, marked off in ml/L and percent by volume. The test is conducted by observing and recording the settling of the sludge every five minutes for the first half hour, then after 60 minutes and after 120 minutes.

The 30-minute reading is most useful to operators in determining how well the sludge will settle. A sludge that settles to around 300 ml/L (or 30%) with a clear supernatant at 30 minutes is considered ideal because it indicates that the sludge will settle rapidly and compact well in the secondary clarifier. A sludge that settles slowly and does not compact in the settleometer, or that leaves a cloudy supernatant will perform similarly in the secondary clarifier. In general, systems that are operating under low F:M ratios and high SRTs will produce a sludge that settles and compacts rapidly and leaves some pinfloc in the supernatant and often small amounts of floating sludge. Systems operating under a high F:M and low SRTs will typically settle and compact more slowly and leave large straggler type floc and a slightly cloudy supernatant. For systems that are operating at the correct F:M ratio and SRT, the mixed liquor will settle to around 300 ml/L in 30 minutes and the supernatant will be clear. If the sludge rises to the top of the settleometer within 120 minutes, it is a sign that the system is actively nitrifying (the sludge rises due to denitrification). In this case, attention should be given to ensure the RAS pumping rate is high enough to prevent rising sludge in the secondary clarifier.

Operators often graph the readings taken every five minutes for the first 30 minutes of the settleometer. Graphing this information yields a characteristic type of curve.



**Figure 10.14 - Settleability Curve**

# SETTLABLE SOLIDS

SAMPLE \_\_\_\_\_

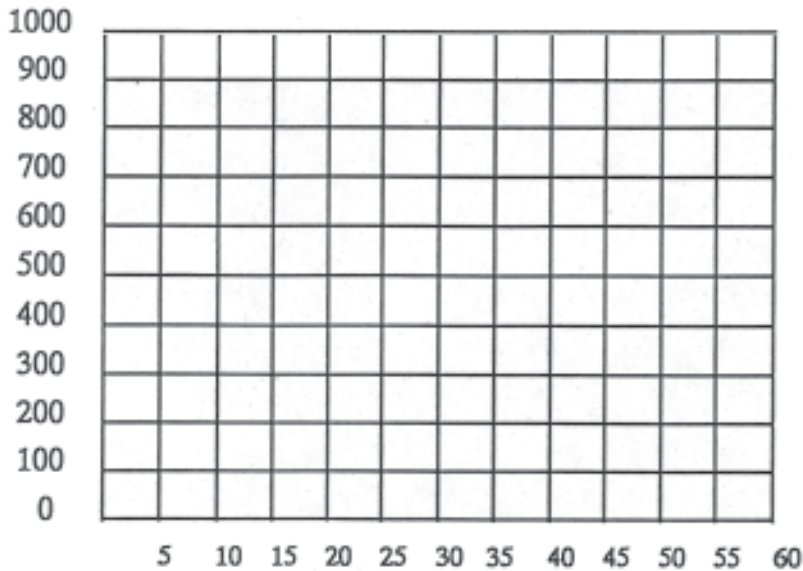
DATE \_\_\_\_\_

ANALYST \_\_\_\_\_

TIME	Vol. occupied by Settled Sludge (MLS)
0 min.	1000
5	_____
10	_____
15	_____
20	_____
25	_____
30	_____
40	_____
50	_____
1 hr.	_____

\*\*\*\*\*

Graph readings versus time:



\*\*\*\*\*

Supernatant Characteristics:

Sludge Characteristics:

\_\_\_\_\_  
\_\_\_\_\_

\_\_\_\_\_  
\_\_\_\_\_

**Figure 10.5 - Settleable Solids**



## **ACTIVATED SLUDGE PROCESS CONTROL STRATEGIES**

All wastewater treatment systems must be operated based upon some process control strategy. Activated sludge plant operators need some procedure to help them maintain control over the four key areas of the process:

- Providing Controllable Influent Feeding
- Maintaining Proper Dissolved Oxygen and Mixing Levels
- Controlling the RAS Pumping Rate
- Maintaining the Proper Mixed Liquor Concentration (controlling the F:M ratio of the system)

For some treatment plants, the operator knows the system very well and understands when it is time to waste, when it is time to change the RAS flow rate, balance the influent load or increase the oxygen provided to the aeration basin. In effect, the operator controls the process through observation, experience and skill. This “seat of the pants” approach is employed successfully by operators all around New Mexico, and does not mean that the system is run poorly or that the operator is not performing his or her job. It does however have one major drawback; when problems do occur (and they will), the operator does not have many options for analyzing what has gone wrong. The ability to predict problems before they occur is also limited by this approach.

Over the 100 plus years that the activated sludge process has been used to treat wastewater, numerous process control strategies have been developed to help operators understand what is happening in the process and make corrections to the system in order to keep it balanced. Some small treatment plants simply use the settleometer as a guide to when they should waste solids from the system. This works in small plants, provided the operator understands that changes to the settleability of the sludge can occur that are not related to the concentration of MLSS in the system. Large activated sludge treatment systems use a variety of process control approaches.

This section will discuss approaches such as the MLSS and MLVSS concentration, the sludge volume index (SVI), the mean cell residence time (MCRT), as well as the use of the light microscope in the control of the activated sludge process.

### **IMPORTANT OBSERVATIONS OF THE PROCESS**

It is easy to get caught up in the more sophisticated approaches to running the activated sludge process and overlook the important basic observations that all operators should be aware of. Sight, sound, smell and even touch

are all invaluable tools for observing what is happening in the process and often provides an obvious indication when something is wrong. Too many operators are intrigued by a new D.O. meter or convinced that the process can be run by calculations alone and forget the basics that must be followed. For example, if something smells septic in the activated sludge process, something is wrong. Activated sludge is (for the most part) an aerobic process. Overall, the system should smell like healthy wet soil when it is operating well. Foul odors indicate a lack of dissolved oxygen, which means trouble.

The color and odor of the mixed liquor can tell you much about how the process is running. If the mixed liquor has a light tan or yellow color, the plant is probably in start-up. This type of mixed liquor does not yet have the healthy organic smell of ideal activated sludge. If the mixed liquor is very dark brown in appearance, it is a sign of old sludge due to a high SRT. This color is common in small package plants that waste only by having a septic hauler remove sludge from the system. Because of the method of wasting, solids are allowed to build up for a long period, which leads to high SRTs prior to the arrival of the septic truck. A significant scum blanket over the aeration basin usually accompanies dark brown mixed liquors. The scum blanket can be light brown to tan in color or even dark brown and leathery. The presence and characteristics of the scum blanket give indications as to what is going on in the process.

There are also many visual cues provided by the secondary clarifier. The sludge blanket in the clarifier should occupy no more than 1/4 to 1/3 of the depth of the clarifier. In general, the less sludge in the secondary clarifier, the better. If chunks of brown sludge are observed floating on the surface of the secondary clarifier (rising sludge), it is a strong indication that the RAS pumping rate should be increased to prevent denitrification from occurring. Large, jagged floc particles (1/8 – 1/4 inch in diameter) exiting over the weirs of a secondary clarifier are a possible indication of too young of a sludge age (low SRT). Small, floc particles the size of the head of a pin exiting in the effluent is usually a sign of a sludge that is too old (high SRT). This is often accompanied by inert matter that forms a film on the surface of the clarifier. This film looks very much as if someone had scattered ashes upon the clarifier. For this reason, this phenomenon is known as “ashing”.

It is critical that operators make the observations of sight, sound and smell to understand what is happening in the activated sludge process. It is also important that operators can make sense of these basic process control observations before moving on to the more complicated process control strategies.

### **MLSS and MLVSS Concentration**

As stated before, one of the key jobs of the activated sludge wastewater treatment plant operator is to maintain the proper F:M ratio in the system. However, activated sludge plants are not operated on a day to day basis based on the F:M ratio. A system's F:M ratio is really just a way of *assessing* the treatment process, not a way of *controlling* it. Part of the reason for this is that the information concerning the influent BOD loading used to calculate the F:M ratio is already 5 days old when an operator receives it because the BOD test takes 5 days to conduct. Decisions about changes to the wasting rate of a system must often be made on a daily basis and the information included in the F:M ratio is already at least 5 days old before it can be applied.

Instead of the F:M ratio, operators often make judgments about the waste rate based on the concentration of the mixed liquor in the aeration basin. This is measured using the total suspended solids (TSS) test on a sample of mixed liquor drawn from the end of the aeration basin, just before entering the secondary clarifier. When the TSS test is used to measure the concentration of mixed liquor, the result is reported as the mixed liquor suspended solids, or MLSS.

If the volatile fraction is also measured, it is reported as the mixed liquor volatile suspended solids concentration, or MLVSS. Most activated sludge processes operate at a MLSS concentration of between 1,000 and 5,000 mg/L. Often, it will be discovered that a particular wastewater plant operates very well at say 2,500 mg/L and so the operator will increase or decrease wasting in order to maintain a MLSS concentration of 2,500 mg/L. In effect, what the operator is doing is maintaining the same overall mass of microorganisms by holding the concentration constant (because the volume of the aeration basin does not change). This has the effect of maintaining the correct F:M ratio.

The percentage of MLSS that is volatile will vary depending upon the rate that solids are digested within an aeration basin. Typically, activated sludge systems operate with a MLVSS concentration that is about 70% of the total MLSS. For systems that operate at high F:M conditions, the percentage is more like 80%. For systems operating under low F:M conditions, the volatile percentage can be as low as 60%. Remember that the MLVSS represents the *living fraction* of the mixed liquor solids. The rest of the MLSS is just inert matter that is trapped in the system, but not providing any treatment to the incoming wastes. Systems operating under high F:M conditions do not have as much time to digest the incoming wastes as effectively as systems that operate under low F:M conditions. This is why the percentage of the MLSS that is volatile is higher for high F:M systems.

Although the activated sludge process can be operated based upon the MLSS and MLVSS concentrations alone, it is not always a good idea to do so. This is because this approach does not take into account all of the solids that are entering and exiting the system on a daily basis. The reason is that the influent hydraulic and organic loading to the system does actually vary from day to day. On a given day, 1,800 lbs. of solids may enter a typical 1.0 MGD treatment plant but that amount may go up to 2,200 lbs./day during a holiday weekend when more people are in town. This results in uneven loading to the treatment system and the operator always attempting to adjust the MLSS/MLVSS concentration after the fact. Unforeseen process upsets can result when using this approach.

### **Sludge Volume Index (SVI)**

The settleometer test yields a great deal of information about how well sludge will settle and compact, but it does not reveal the MLSS concentration. It would seem obvious that if the MLSS concentration increases, the settling rate would slow down. (That is; thicker mixed liquor should settle more slowly). To some extent, this holds true, but it is not always the case. The reason has to do with the fact that the type of microorganisms in the mixed liquor has more to do with how the sludge will settle and compact than the concentration does.

When an activated sludge process is operating well, it will primarily contain a mixture of simple round and rod shaped bacteria, an assortment of higher life forms known as protozoa, and a few long, hair-like filamentous bacteria that add strength to the bio-flocculated structure (known as floc). If the right conditions cannot be maintained in the system, this balance of microorganisms in the floc will change. For systems operating at very high F:M ratios and low SRTs, the organisms do not remain in the system long enough for the slower growing protozoa to appear.

For this reason, this condition is referred to as "young sludge". The settling characteristics of young sludge are slow, and a cloudy supernatant, laden with large straggler floc particles is left behind.

If the system is operating at a very low F:M ratio and a high SRT, larger, slow growing organisms such as rotifers and sludge worms will begin to appear. This condition is often referred to as "old sludge". Old sludge tends to settle very rapidly but leaves pin floc in the supernatant and a surface material known as "ashing". Ashing appears just as though ashes were scattered on the surface of a settleometer test or secondary clarifier.

One of the most common problems that arise in the activated sludge process is the proliferation of excessive amounts of filamentous type bacteria. The problem has many causes, including septic conditions, low D.O.

conditions and operating the system at the wrong F:M ratio. The growth of excessive numbers of filamentous bacteria results in a floc that cannot separate from liquid due to the hair-like projections of the filaments.

This condition is known as “sludge bulking”, and it can lead to the total loss of the solids inventory in the treatment system as the sludge is washed out of the secondary clarifier. (This problem is discussed in detail further in this text).

The MLSS test provides information about the concentration of solids in the aeration basin, but does not give insight into the settling characteristics of the sludge. The settleometer test gives insight into the settling characteristics of a particular sludge, but does not take into account the MLSS concentration.

In order to analyze the settling characteristics *at a given* MLSS concentration, operators calculate a value known as the sludge volume index, or SVI. The SVI of mixed liquor is determined by knowing both the sludge’s settling characteristics and its MLSS concentration.

The SVI is an index of how well a sludge will settle at a given MLSS concentration. This means that it does not matter if the mixed liquor is at 1,500 mg/L or at 3,500 mg/L when the settleometer test is performed, the settling characteristics can be quantified. (See calculations on the following page.)

The SVI is most useful at identifying filamentous organism outbreaks, allowing operators to respond before the system is out of control. For most activated sludge treatment plants, a SVI range of 80 – 120 signals good treatment. SVI values of <80 indicate older, fast settling sludge and the need to waste solids, however, some SBR systems operate constantly in this range. SVI values over 150 almost always indicate a serious filamentous bacteria outbreak that must be dealt with before the entire solids inventory is lost from the system.

Understand that these ranges give a good indication of where most plants operate well and when most plants will get into trouble, but they are not hard and fast rules. This is because different systems have different secondary clarifiers. Shallow, poorly baffled secondary clarifiers do not respond well to bulking conditions, whereas deep, well-baffled clarifiers can handle SVI values at or above 150 before losing the sludge blanket to washout. If the equipment is available to measure the settleability and the MLSS concentration of a mixed liquor, the SVI value offers operators a powerful tool for assessing the condition of the biological process. When used by a conscientious operator that knows the history of their system, changes in

the system’s SVI value can even be used to predict filamentous bacteria induced sludge bulking problems and then measures can be taken to stop them early.

### **Mean Cell Residence Time (MCRT)**

Because of the time delay involved in generating the data used to determine the F:M ratio, it is not used to control the secondary treatment process, however, a similar approach, based on other information that can be collected in a timely manner, can be used. The mean cell residence time (MCRT) approach to balancing the solids in the activated sludge treatment system offers a simple and effective way to operate the activated sludge process ahead of the curve. What the MCRT approach attempts to do is account for all of the solids that are in the system as well as all of the solids that exit the system everyday. A system’s MCRT is a representation of the average time (in days) that a bacterial cell will remain in the system before being removed as WAS or leaving in the effluent. The calculation is made by dividing the total pounds of MLSS in the aeration basin by the total pounds wasted each day and the total pounds that exit the in the effluent each day. (See calculations on the following page.)

A system’s MCRT is very similar to its SRT, except that the MCRT looks at what is leaving the system each day and the SRT looks at what is coming into the system each day. Typically, conventional activated sludge systems run at MCRTs of < 15 days, whereas extended aeration systems run at MCRTs of > 15 days. Contact Stabilization systems, due to their high loadings and high wasting rates tend to run at MCRTs of < 5 days.

In order to use the MCRT approach, daily information about a system’s MLSS concentration, WAS concentration, WAS flow, effluent TSS concentration and effluent flow are needed. Not all treatment plants can generate this amount of process control data everyday. If these pieces of information are available, the actual number of pounds of WAS that must be removed from the system in order to maintain the same solids balance (same MCRT) can be calculated. (See following page for an example of this approach to process control.)

It is important to understand that the minutes of WAS pumping that are required each day to maintain the desired MCRT will change from day to day, but that does not mean that the operator should change the pump setting everyday to try to adjust the system. This type of over management of the wasting rate tends to destabilize the activated sludge process. To compensate for this, the MCRT approach to process control should be used based upon a seven-day running average. In other words, seven days worth of WAS pump adjustments are averaged, and that average is what

Determine the required WAS lbs./day in order to maintain the desired MCRT:

$$\frac{(20,000 \text{ lbs. MLSS in Aeration Basin}) - (200 \text{ lbs./day Lost to Effluent})}{9.5 \text{ day desired MCRT}} = 2,084 \text{ lbs./day WAS}$$

Determine the WAS flow in MGD to waste the required number of lbs./day:

$$\frac{2,084 \text{ lbs./day WAS}}{(15,000 \text{ mg/L WAS}) \times (8.34)} = 0.0167 \text{ MGD of WAS}$$

Convert the WAS flow from MGD into gallons per day (gpd):

$$(0.0167 \text{ MGD of WAS flow}) \times 1,000,000 = 16,700 \text{ gpd of WAS flow}$$

Determine the WAS pump run time to achieve the required wasting:

$$\frac{16,700 \text{ gpd of WAS flow}}{150 \text{ gpm WAS pump rate}} = 111 \text{ minutes of WAS pumping each day}$$

**Figure 10.16 - Calculating WAS Based on MCRT and MLSS**

$$\frac{20,000 \text{ lbs. MLSS in Aeration Basin}}{(1800 \text{ lbs./day WAS}) + (200 \text{ lbs./day Lost to Effluent})} = 10 \text{ day MCRT}$$

**Figure 10.17 - Calculating MCRT**

$$\frac{30\text{-Minute Settability Reading (in ml/L)} \times 1000}{\text{MLSS Concentration (in mg/L)}} = \text{SVI}$$

**Figure 10.16 - Calculating SVI**

the pump is actually set to run each day. The following example explains:

Day	WAS pumping each day (calculated)	The next day: Day	WAS pumping each day (calculated)
Monday, August 10th	114 minutes	Tuesday, August 11th	118 minutes
Tuesday, August 11th	118 minutes	Wednesday, August 12th	113 minutes
Wednesday, August 12th	113 minutes	Thursday, August 13th	115 minutes
Thursday, August 13th	115 minutes	Friday, August 14th	107 minutes
Friday, August 14th	107 minutes	Saturday, August 15th	116 minutes
Saturday, August 15th	116 minutes	Sunday, August 16th	111 minutes
Sunday, August 16th	111 minutes	Monday, August 17th	105 minutes
Average	113 minutes actual WAS pumping on Sunday, August 16th	Average	112 minutes actual WAS pumping on Monday, August 17th

Using a seven-day running average prevents large changes to the wasting rate at any one time. It is very important that large changes are not made if the system is to operate as a stable process. Even if the seven-day running average



is not used, a good rule of thumb to follow is “never change the waste rate by more than 10% a week”.

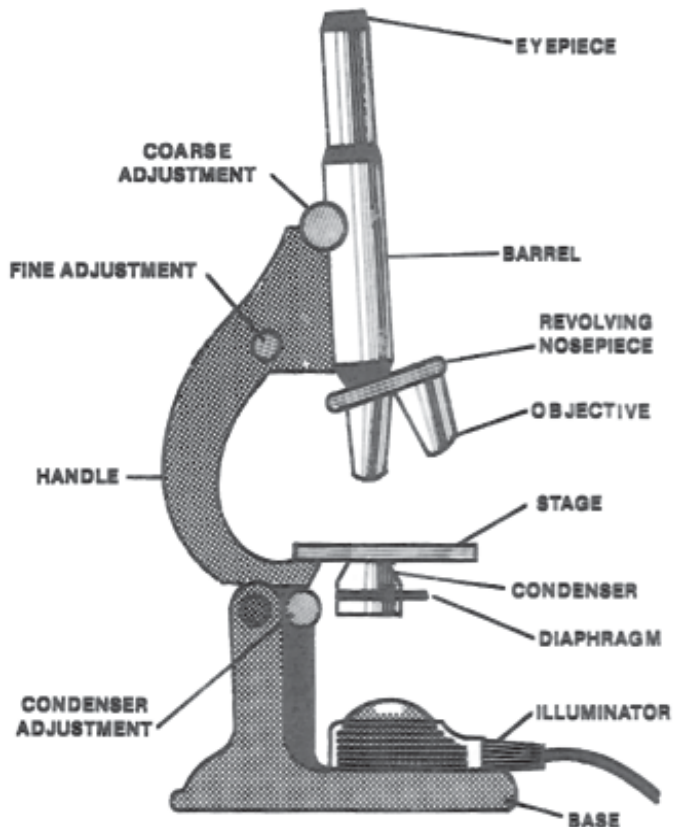
The MCRT approach offers a valuable method of balancing the solids in an activated sludge system. It is particularly suited to plants that treat 1.0 MGD and more, because these treatment facilities have the necessary in-house laboratory capability to generate the needed data. It must be applied to a treatment plant in a consistent manner and is only as good as the laboratory sampling and analysis. Any error introduced through non-representative sampling or inaccurate flow measurements will be magnified as errors in the MCRT calculation. It takes skilled operators to apply effectively, but treatment systems that use the MCRT approach have fewer upsets and can recognize problems well ahead of time and address them compared to systems that are run by “the seat of the pants”.

### LIGHT MICROSCOPE

When the public or a beginning operator considers the mixed liquor in the aeration basin, their impression is that muddy water is being aerated and mixed in a large tank. It is often very hard for non-operators to understand that the mixed liquor represents a mass of *living organisms!* This is the reason that so many people react as they do when viewing mixed liquor under a light microscope for the first time. It is not at all unusual for people to respond with surprise and excitement upon seeing activated sludge “bugs” (living organisms). Beyond the novelty of the light microscope lies one of the most powerful tools for assessing the activated sludge process that is available to operators. The ability to directly view the type and activity of the microorganisms involved in the process offers unparalleled insight into what is happening. As a further endorsement, the use of the light microscope is actually quite simple.

A modern light microscope is an instrument consisting of a light source, a stage where the object to be viewed is placed, an objective lens where light from the object is first magnified and an eyepiece, where the magnified image is again enlarged and viewed. Some provision for focusing the image, moving the viewed object around and controlling the light source is generally also provided. For activated sludge work, a microscope with objective lenses that will magnify to 4, 10, 40 and 100 power (X) are generally recommended. Most eyepieces provide an additional magnification of 10X, resulting in overall magnifications of 40, 100, 400 and 1000 times the original size of the object being viewed. (See graphic on the preceding page.)

Samples of mixed liquor are best obtained from the settled sludge in a fresh settleometer test, or from a sample taken directly from the exit point of the aeration basin. For viewing live organisms, the sample should be as fresh as



**Figure 10.19 - Schematic of a Compound Light Microscope with Built-in Light Source**

possible. To prepare a sample to be viewed with a microscope, place a drop of the sample on a clean glass slide and cover it with a small, thin piece of glass, known as a cover slip. The cover slip prevents the sample from drying out too fast and prevents the lenses from accidentally contacting the wet sample. The light source should be adjusted in order to obtain the maximum contrast between light and dark. Too much light washes out the object, too little does not allow enough contrast to see details. Slides should be viewed first using the low power 4X objective lens.

Once an organism of interest is located, the higher power objectives can be used to discern greater detail. Be aware that the highest power objective lens, (100X), is used in conjunction with optical oil that is placed between the lens and the cover slip in order to allow a full field of view. (This practice is known as “oil immersion”). This 1000X magnification is generally only used when attempting to identify specific aspects of microorganisms, such as cell separations (septa) in filamentous bacteria.

For routine viewing of living mixed liquor, the 10X and 40X lenses will be most useful. Begin by slowly moving back and forth across the slide until the entire contents of the slide has been viewed. This is easily accomplished

when using the lower power lenses, which have a wide field of view. Most of what you will see in activated sludge appears as brown and tan clumps of particles. These particles are masses of round and rod shaped bacteria, which are referred to as *floc* particles. The first thing that should be assessed is the *floc structure*. Are the floc particles large, solid, and light brown with clear supernatant between? This is a sign of a healthy and good settling sludge. If the particles are small and very dense and the supernatant has a lot of debris in it, it is a sign of an unhealthy sludge that will leave a cloudy supernatant. This is typical of mixed liquor from systems that have excessively high solids (low F:M) or that are operating with excessive dissolved oxygen. If the floc particles are not very dense, light in color and appear weak, the sludge will most likely settle slowly and leave behind large, “straggler floc”. This is typical of systems that are in start-up or are operating under too high of an F:M.

Look at the other life forms that are present. You will no-doubt see a mixture of higher life forms, such as; Amoebas, free swimming and stalked Ciliates, Flagellates, Rotifers and even sludge worms. The mix of higher life forms can tell you a great deal about how the system is operating. For instance, activated sludge that is made up of loose floc particles and a mixture of mostly amoebas, Flagellates, and some free swimming Ciliates is indicative of a young sludge (high F:M). A mixture of dark, dense floc particles and Rotifers, stalked Ciliates and sludge worms is typically found in older sludge (low F:M). Activated sludge that has strong, medium sized floc particles and a mixture of all of these organisms, (especially with large clusters of stalked Ciliates and free swimming ciliates), is typical of systems that are operating at an F:M that is well suited to capturing and metabolizing the incoming waste. Sludge with these characteristics will settle and compact well and leave a clear supernatant that has low BOD and TSS.

Every aspect of these higher life forms can give you information about the health of the system. The size, number, activity level, type and diversity of the higher life forms in activated sludge can all be used as key indicators. The F:M that a system is operated at will directly influence the types of bugs that predominate. High F:M systems that process waste at a high rate and waste it out before it is fully digested will tend to cultivate fast growing, high activity organisms (free swimming Ciliates, Flagellates, Amoebas). Low F:M systems that have long MCRTs do a thorough job of digesting the captured waste and tend to operate with slower growing, lower activity organisms (Rotifers, sludge worms, Tartigrade). Systems where the F:M is correct for the waste load will be predominated by a mixture of organisms that grow fast and a few that grow slow. The activity of the organisms in this type of system

will be high when first encountering the waste and then will slow as the waste is metabolized. All of this can be seen through the lens of a microscope when used with care.

Next, take a careful look at the spaces between the floc particles. Are there any long, hair-like organisms projecting out of the floc particles? These are filamentous bacteria. Believe it or not, filamentous bacteria of this type are some of the oldest microbes on our planet and have survived unchanged for millions of years. This makes these types of bacteria able to adapt to many different environments and fill many niches where other life forms cannot survive.

When these filaments are present in the right amount in mixed liquor, they form the “backbone” of the floc particles, which adds strength and density to the floc. However, when these filamentous bacteria grow too numerous, they tend to keep the floc particles from being able to come together. This is the result of the shape of the filaments themselves, which act like the fibers in fiberglass house insulation, which maintains the “loft” that provides the insulation layer. If enough filamentous bacteria are present, they can actually prevent any settling and solids separation from occurring. When this phenomenon occurs in mixed liquor, the sludge is said to be “bulking”.

When viewing filamentous bulking using a light microscope, the filaments will sometimes be seen inside the floc particles themselves. When this occurs, the floc becomes expanded and cannot settle. This is known as an “open” floc structure. In other instances, the filamentous bacteria will extend from one floc particle to another. This is known as filamentous “inter-floc bridging”. Bridging of this type can result in the worst sludge bulking episodes. If no action is taken, serious bulking can lead to solids washout in the secondary clarifiers, resulting in permit violation and environmental impacts.

Filamentous bacteria can also be responsible for foaming problems. Typically, activated sludge foaming problems are related to the amount of fats, oils and grease that a facility receives. In general, WWTFs that receive large amounts of fats, oils and grease experience foaming problems at least once or twice per year. Sometimes the problem is continuous. Plants that do not have adequate pretreatment facilities (barscreen) also experience foaming problems. These foaming problems result from filamentous bacteria that survive on the grease and oil that floats on the surface of aeration basins. Some types of filamentous bacteria have evolved to become buoyant. In this way, they alone are in contact with the fats and grease that they use as food. When a large slug of grease enters the aeration basin, these organisms quickly break down the grease, which results in the formation of a foam layer.

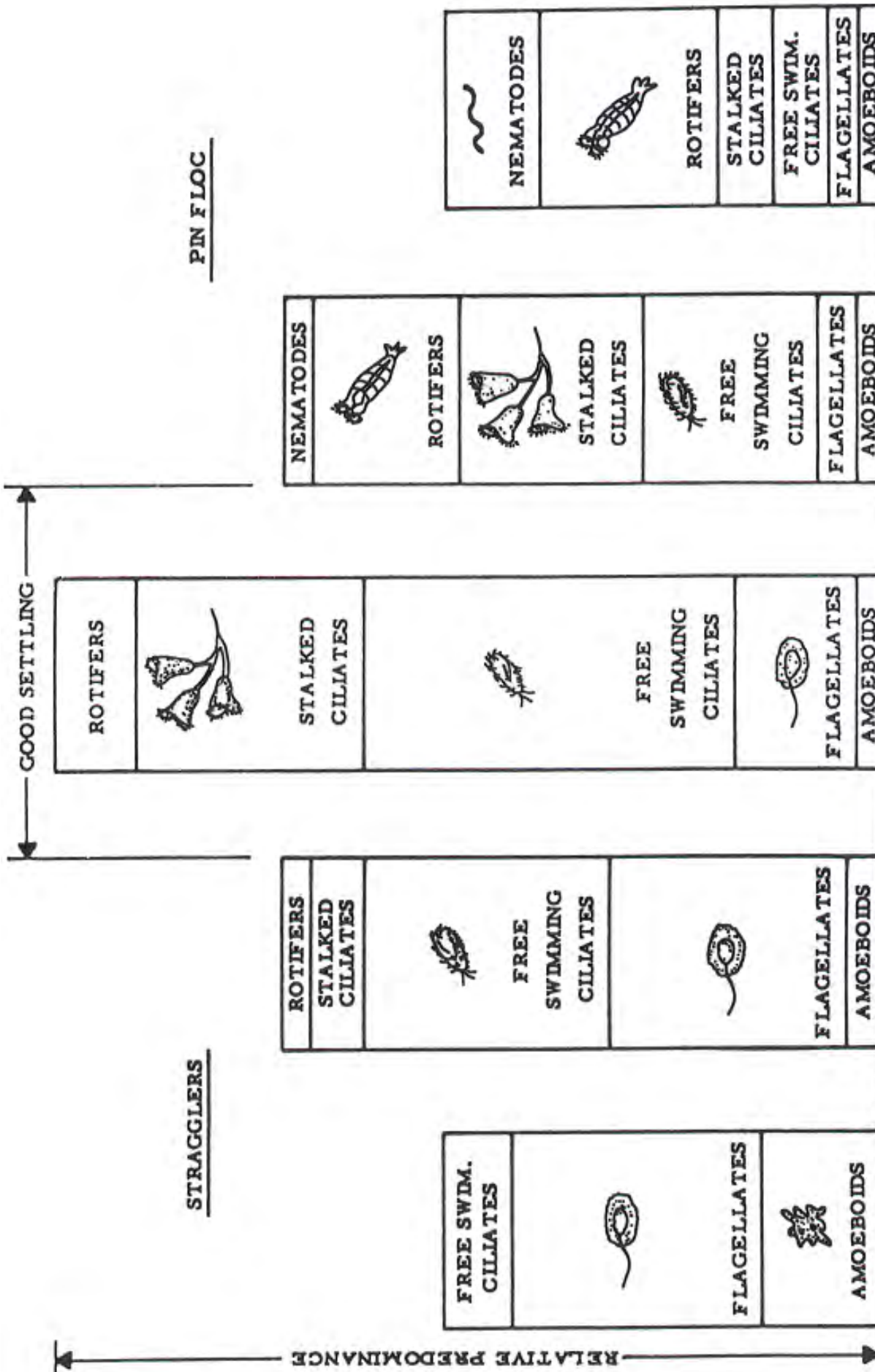
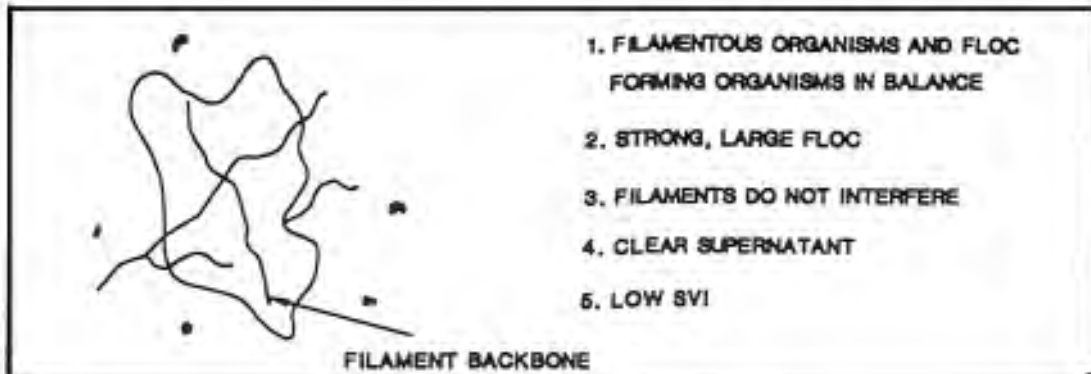
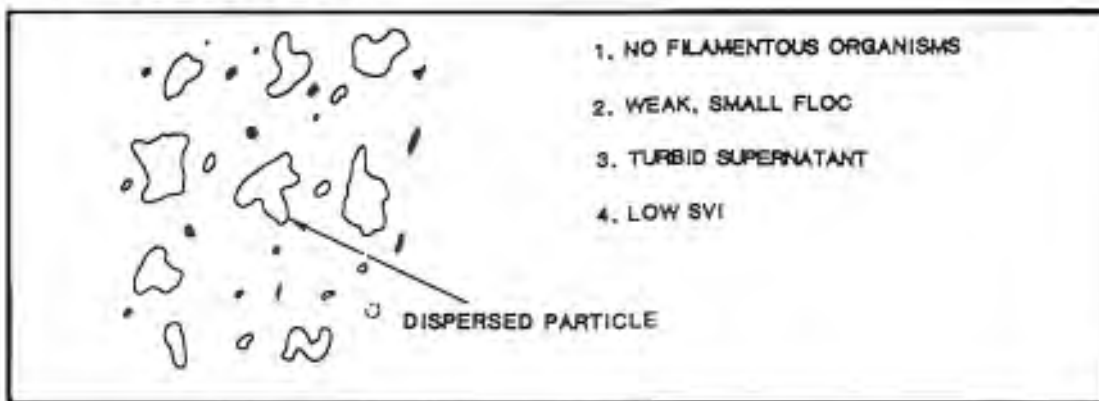


Figure 10.20 - Microorganisms vs Sludge Quality

**A. IDEAL, NON-BULKING ACTIVATED SLUDGE FLOC**



**B. PIN-POINT FLOC**



**C. FILAMENTOUS BULKING ACTIVATED SLUDGE**

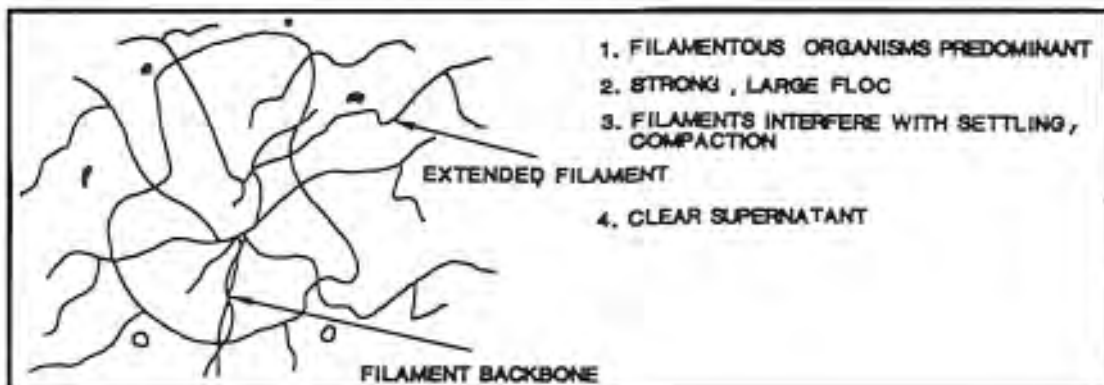


Figure 10.21 - Effect of Filamentous



Beyond the numbers of filamentous bacteria and whether they occur within the floc itself, in inter-floc bridging or in foam, you can observe the type of filamentous bacteria that you are dealing with using a microscope. However, identifying different types of filaments can be time consuming and difficult. Furthermore, a specialized type of light microscope, known as a phase-contrast microscope is used for this type of work. When the type of filamentous bacteria responsible for a bulking episode can be identified, the cause of the over proliferation of the filaments can often be understood.

Filamentous bacteria identification and the conditions that lead to the growth of different types of filamentous bacteria is discussed in great detail in the Manual on the Causes and Control of Activated Sludge Bulking and Foaming, 3<sup>rd</sup> edition., by David Jenkins, Michael G. Richard and Glen T. Daigger. As this manual explains, filamentous bacteria are classified under a system that gives some of the bacteria actual names and identifies others using numbers. The following table describes some filamentous organisms and the conditions under which they grow:

**ACTIVATED SLUDGE PROCESS PROBLEMS, TROUBLESHOOTING AND CORRECTIVE MEASURES**

Although the activated sludge process can produce an amazingly high quality effluent when it is working well, problems can and do arise. The main problems that occur in the activated sludge process include; solids separation problems, foaming problems, shock loads, septicity and die-off of the microorganisms.

**Solids Separation Problems**

Probably one of the most vexing problems encountered by operators of the activated sludge process is the problem that arises when the solids will not separate (settle) from the supernatant. This problem has a variety of causes, but the phenomenon are grouped into what is called “bulking”. Strangely, the supernatant that does exist during episodes of bulking is often very clear, but the solids will simply not settle and compact enough, and solids washout results.

We have already discussed sludge bulking that can be caused by filamentous type bacteria. In this problem, it is the shape of the filamentous bacteria themselves that prevents the solids from settling and compacting. However, other types of solids separation problems also occur. When an imbalance exists in the nutrients of the waste stream entering an activated sludge system, many of the microorganisms in the mixed liquor will form a large amount of viscous, gelatinous slime. This is the same material that draws the organisms together during bio-flocculation. When formed in excessive amounts, the gelatinous slime can cause a type of non-filamentous bulking, known as “viscous bulking”. This problem most often occurs at treatment plants that treat industrial wastes, which can be deficient in nutrients such as phosphorous and nitrogen.

A different kind of bulking problem can be encountered during the winter months, when cold-water temperatures make it easy to supersaturate the aeration basin with oxygen. In this type of bulking, the super-saturation of oxygen causes the mixed liquor to remain neutrally buoyant

<i>Filamentous Bacteria Type</i>	<i>Problem(s) Created by Overgrowth</i>	<i>Conditions That Encourage Over-growth</i>
Type 1701	Open floc structure induced bulking	Low D.O.
Sphaerotilus Natants	Inter floc bridging induced bulking	High F:M, Low D.O.
Microthrix parvicella	Inter floc bridging induced bulking and persistent “pumice” like tan foam on aeration basin.	Excessive Fats, Oils and Grease, Low F:M, growth increases during times of temperature change
Type 021N	Open floc structure and inter floc bridging induced bulking	Septic Conditions, Low F:M, Nutrient Deficiency
Thiothrix I & II	Inter floc bridging induced bulking	Septic Conditions, Nutrient Deficiency
Haliscomenobacter Hydrossis	Inter floc bridging induced bulking	Low D.O.
Nocardia	Persistent “leathery” dark brown foam on aeration basin with open floc structure	Excessive Fats, Oils and Grease, aggravated by cold temperatures
Beggiatoa sp.	Open floc structure and inter floc bridging induced bulking	Septic Conditions
Fungi	Open floc structure	Low pH in influent or aeration basin (common in systems that nitrify)

**Table 10.1 - Filamentous Bacteria Types**

and settle very slowly. This is often accompanied by chunks of sludge rising to the surface of the secondary clarifier, much like denitrification. The problem is easily corrected by reducing the aeration supply.

During episodes of sludge bulking (whatever the cause), operators have a natural tendency to increase the RAS flow in order to remove the rapidly building sludge blanket from the secondary clarifier. Unfortunately, this only compounds the problem as the hydraulic loading on the clarifier increases and the clarifier ultimately fails due to the high hydraulic loads. Always remember, any amount of RAS that is pumped from the bottom of a clarifier quickly returns to that clarifier as inflow. Although increasing the RAS flow to remove solids from the clarifier appears at first logical, it is only treating a symptom of the bulking. Whenever dealing with sludge bulking problems, it is important to treat the problem, not the symptoms. At the onset of bulking, it would be wiser to lower the RAS pumping rate, even though to many, this seems counterintuitive.

Conditions such as; low pH, low D.O., septic influent or recycle streams and nutrient imbalances have all been demonstrated to encourage sludge bulking. The most common cause is through the overgrowth of filamentous bacteria. As discussed in the above section on the use of the light microscope, filamentous bacteria are associated with specific conditions that foster their growth. By knowing which filament is causing the problem, the conditions that allowed their growth can be identified and corrected. For this reason, whenever bulking occurs, plant records should be reviewed in an attempt to locate the cause of the problem. Identification of the cause will not remedy the present bulking condition, but it will shed light upon the underlying root of the problem, and measures can then be taken to correct the problem and prevent the same conditions from occurring again.

The old saying that “one ounce of prevention is worth a pound of cure” is very true when it come to filamentous bulking problems. To prevent sludge bulking from occurring, the following items should be carefully controlled in an activated sludge plant:

1. Maintain the correct F:M ratio. Carefully review plant records to determine what F:M ratio produces the best quality effluent and long term settling stability. Keep track of influent solids loadings and maintain the desired level of solids in the aeration basin through careful regulation of sludge wasting rates.
2. Prevent low D.O. levels from developing in the aeration basin. The concentration of D.O. in the aeration basin can be determined quickly and

accurately using a calibrated field D.O. meter. This check should be performed on activated sludge at least once a week. There is no reason for persistently low D.O. concentrations to exist during normal conditions, provided the aeration system is adequate. However, peak flows and slugs of high-strength waste will cause the aeration basin D.O. levels to sag. Remember that the level of D.O. that must be maintained in the system in order to fully metabolize the waste load is a function of the F:M (explained earlier in this text). As a general rule of thumb, try to maintain at least 1.0 mg/L.

3. Stop grease from entering the aeration basin. This is particularly important when dealing with filaments such as *Microthrix parvicella* and *Nocardia*. Controlling grease discharges to sewers, using tight mesh barscreens or fine screens and employing primary clarifiers are the best methods for reducing grease in the aeration basin.
4. Employ anoxic zones or an anoxic cycle in the treatment train. Anoxic zones create a location where the soluble BOD in the influent is taken up very rapidly by the desirable bacteria in the mixed liquor. Many filamentous type bacteria have a hard time competing in this environment. In effect, the anoxic zone “selects” against their growth. For this reason, anoxic zones are sometimes called “selectors”. A side benefit is the controlled denitrification that can be obtained in an anoxic zone. You can learn more about anoxic zones in Chapter 13 - Nitrogen Removal
5. Take care not to recycle filaments back into the process by digester supernating or filtrate recycling.

Table 10.2, “*Causes & Observed Effects of Activated Sludge Separation Problems*” summarizes the types of solids separation, observed effects and possible remedies for commonly encountered problems in activated sludge systems.

### **RAS Chlorination**

When filamentous bulking problems reach the extent that large amounts of solids are washing out of the secondary clarifier, it is time for drastic measures to be taken to regain control of the situation. One way of doing this is through the introduction of a toxic substance, such as chlorine, into the mixed liquor with the intent of killing the filamentous bacteria. Typically, chlorine is applied to the RAS pumping stream and so this method is known as “RAS Chlorination”. Although it is difficult to control, RAS chlorination can be used quite effectively as a means of reducing bulking caused it is a method of last resort and should only be used when other control methods have failed.

**Table 10.2**  
**Causes, Observed Effects and Remedies of Activated Sludge Separation Problems**

PROBLEM	CAUSE	OBSERVED EFFECT(S)	POSSIBLE REMEDY
Dispersed growth	Microorganisms do not form floc and so are dispersed, forming only small clumps or single cells.	Turbid effluent. No zone settling of sludge.	<ol style="list-style-type: none"> <li>(1) Check for excessive turbulence or over-oxygenation in the aeration basin (floc shear). Reduce turbulence if excessive.</li> <li>(2) Look for evidence of a toxic influent and control if possible.</li> <li>(3) Re-seed the aeration basin with live microorganisms if necessary.</li> </ol>
Non-filamentous bulking or "Viscous Bulking"	Large amounts of exocellular slime are present in the floc. In severe cases, the slime imparts a jelly-like consistency to the activated sludge.	Reduced settling and compaction rates. Virtually no solids separation in severe cases resulting in overflow of sludge blanket from secondary clarifier. In less severe cases, viscous foam is present.	<p>Investigate nutrient imbalance, especially nitrogen and phosphorus. The ratio of influent nutrients should be around:</p> <p>1% phosphorus            5% nitrogen            94% carbon</p> <p>Supplement nutrients if needed.</p>
Pin floc or Pinpoint floc in supernatant	Small, compact, weak, roughly spherical floc are formed, the larger of which settle rapidly. Smaller aggregates settle slowly.	Low SVI (< 100) and a cloudy, turbid effluent.	Raise F:M by lowering MLSS concentration in a controlled manner.
Large, jagged "straggler floc" in supernatant	Incomplete bio-flocculation, which leaves some large particles in the supernatant.	Slow settling and compaction during first 30 minutes of the settleometer test, although the SVI is only slightly elevated. This is common during plant start-up, when the mixed liquor is building or in plants that are organically overloaded.	<ol style="list-style-type: none"> <li>(1) Lower F:M by building up mixed liquor.</li> <li>(2) Increase aeration basin volume.</li> </ol>
Bulking	Filamentous organisms cause an open floc structure or inter-floc bridging and interfere with compaction and settling of activated sludge.	High SVI (Typically > 150) - very clear supernatant. Decreasing RAS and WAS solids concentrations. In severe cases, solids washout occurs where the sludge blanket is lost from the secondary clarifier. Solids handling processes become hydraulically overloaded.	<ol style="list-style-type: none"> <li>(1) Lower RAS pumping rate to prevent solids washout.</li> <li>(2) Reduce MLSS concentration by ¼ - 1/3. (Lean the system out).</li> <li>(3) Identify the causative filament(s) and correct conditions that allowed growth.</li> <li>(4) Chlorinate the RAS (last resort).</li> </ol>
Rising Sludge	Denitrification in the sludge blanket releases N <sub>2</sub> gas, which floats chunks of activated sludge to the surface of the secondary clarifier.	Large chunks of activated sludge found on the surface of a secondary clarifier. If allowed to accumulate, a thick layer of sludge will form on the clarifier surface.	<ol style="list-style-type: none"> <li>(1) Increase RAS pumping rate.</li> <li>(2) Lower MLSS concentration in a controlled manner.</li> </ol>
Foaming/ Scum formation	Caused by the presence of grease and non-degradable surfactants. <u>Microthrix parvicella</u> and <u>Nocardia</u> sp. are the primary filamentous bacteria that cause the problem.	Foams float large amounts of activated sludge solids to surface of treatment units. <u>Nocardia</u> and <u>Microthrix</u> foams are persistent and difficult to breakup mechanically. Foams accumulate and can putrefy. Solids can overflow into secondary effluent or overflow tank walls onto walkways. Foam exiting in the effluent can be cited as a permit violation.	<ol style="list-style-type: none"> <li>(1) Stop grease from entering the sanitary sewer.</li> <li>(2) Improve plant pretreatment (tighter mesh barscreen).</li> <li>(3) Increase wasting to remove grease from the system, after the supply has been stopped.</li> <li>(4) Stop decanting from digester (this recycles grease in the system).</li> <li>(5) Install primary clarifier to remove grease before it enters the aeration basin.</li> </ol>



Furthermore, it is very easy to make the situation far worse if RAS chlorination is performed improperly. Excessive RAS chlorination can result in and total die-off of all of the organisms in the aeration basin. At the very least, the population of nitrifying organisms (which are very sensitive to environmental changes) will almost always be killed off. This leads to an increase in the effluent ammonia concentration following RAS chlorination. It should always be understood that RAS chlorination is a method to be used as a short-term fix to the problem. Eliminating the conditions that cause excessive growth of filamentous bacteria offers a much more effective way of controlling bulking over the long-term.

The theory of applying chlorine to the RAS relies upon the idea that because the filamentous bacteria stick out into the bulk solution, they are more prone to be damaged by the chlorine than the round and rod shaped bacteria that form the floc particles themselves. This is true if the filament in question is causing inter-floc bridging type bulking. However, RAS chlorination can be significantly less effective on filaments that occur in the floc itself and create an open floc structure.

To be effective, RAS chlorination must be applied at the proper dosing rate over a period of time that spans only a couple of days or a week at the most. In general, it is not a technique that should be used over long periods. If chlorine is to be applied to the RAS, several important pieces of information must be accurately known. One of these is the total number of pounds of MLVSS in the system. This is because the chlorine dose is based upon this number.

For RAS chlorination, chlorine is applied at a rate of 1 – 10 pounds of chlorine per 1000 pounds of MLVSS in the system per day. It is best to start at the low end of the scale, apply the chlorine for 24 hours and observe the effects. The importance of spreading the chlorine application out over the full 24 hours cannot be overstressed. The same result cannot be obtained by applying 10 kilograms of chlorine over 3 – 4 hours as those that can be obtained by applying 10 kilograms of chlorine over 24 hours. Also of great importance is the need to mix the chlorine rapidly and thoroughly throughout the RAS flow stream. In order to be effective, the chlorine must contact as many of the filamentous bacteria as possible. This is best accomplished by injecting the chlorine into the RAS line ahead of an elbow or pump, where the natural turbulence will mix the solution into the RAS. Solutions made up of chlorine gas are much more effective than solutions of bleach or HTH. The reason for this is not entirely clear, but experience has proven it true.

As RAS chlorination is begun, it is important to carefully observe the effect that the chlorine is having on the mixed liquor. There are three main items to look for:

- When viewed under a microscope, the filamentous bacteria should be seen to “break” as well as curl back upon themselves. This is caused by the direct action of the chlorine damaging individual cells. When the chlorine dose is correct, the effect will be widespread. The higher life forms (Ciliates, Rotifers, Flagellates) should be observed to still be alive and active.
- The SVI should begin to drop. The change should be evident within the first day if the chlorine dose is correct.
- The sludge blanket in the clarifier should begin to compact better. Within several days, the RAS and WAS concentrations should begin to increase as evidence of the improved compaction. The level of the sludge blanket should begin to drop and solids washout should stop.

As mentioned earlier, even when performed correctly, RAS chlorination results in a degraded effluent quality. The Heterotrophic bacteria that are responsible for BOD removal are also killed off to some extent and the nitrifying bacteria suffer badly. However, if the dose is correct, these organisms will rebound within a matter of weeks and the system will slowly return to normal operation.

If the chlorine is over applied, the result will be a complete kill-off of the mixed liquor. The aeration basin will turn a pale tan color or even white/gray. The effluent will resemble raw wastewater and discharge permit violations will occur. At this point, the approach has failed and the system will need to be reseeded with living mixed liquor. RAS chlorination offers a method of dealing with filaments, but it can be a very heavy handed sword if not used with caution. RAS chlorination is not recommended for continuous use.

### **Foaming Problems**

Operators of activated sludge systems may encounter a variety of foam and scum problems. Non-degradable detergents, grease, oil and other unknown substances can all create foam and scum. Most types of foams that are caused by detergents can be controlled by simply hosing them down regularly. Other foams can be extraordinarily persistent and even seem to have a life of their own. For the worst of the foams, this description is very appropriate, because filamentous bacteria that feed upon grease and oil cause the foams.

Surprisingly, some filamentous bacteria, such as *Nocardia*, can be responsible for severe foam problems but do not



typically cause sludge bulking problems. Other organisms, such as *Microthrix parvicella* cause severe foaming and bulking problems, at the same time. Because of this fact and the fact that it does not respond well to the selector effect, *Microthrix parvicella* is perhaps the most difficult filamentous bacteria to combat.

Generally, the persistent foams are the result of filamentous bacteria metabolizing grease and oil. These filaments have adapted to be buoyant, which allows them to exist and grow at the surface of the aeration basin, where the grease and oil can be found. In an aeration basin, there is very little competition for this food source, so these filaments can grow unchecked. As the number of filaments increases, the foam grows. Over time, MLSS solids will become trapped within the foam, adding to its size.

The only effective long-term solution is to interrupt the food supply by stopping the grease and oil from entering the aeration basin in the first place. The most effective means for accomplishing this is to enforce sewer use ordinances that ban the discharge of oil and grease into the sanitary sewer. If this cannot be accomplished, a tight mesh barscreen or even a fine screen can be employed to remove the oil and grease at the plant headworks. Properly designed and operated primary clarifiers can also do a good job of removing grease before it can enter the aeration basin.

Floating sludge and floating scum can also create foam. Much of the time, these unstable foams can be kept in check using water sprays. The higher the MLSS concentration, the more susceptible an aeration basin is to foaming. Furthermore, the aeration rate directly affects the height of the foam that will result. Often, a brown foam layer over an aeration basin is simply a sign that the system is carrying excessive solids. Increasing the wasting rate until the MLSS concentration is brought down to the appropriate level can cure this problem.

Operators have attempted many methods to combat the various foams that occur on aeration basins. Chlorine surface sprays, steam boxes and hydrogen peroxide injection have all been used to reduce foam, although their effectiveness is often questionable. RAS chlorination is NOT effective against foam.

Aerobic, anoxic, and anaerobic selectors have been used to prevent the growth of filamentous foam microorganisms by creating an environment in which they are at a competitive disadvantage to non foam forming organisms. These are usually employed at the head of the aeration basin. As more information is gained about these techniques, they will be employed on a wider basis.

Remember that not all foam is a bad thing. A small amount of crisp white foam on the surface of a aeration basin is a sign of a system that is operating at the ideal F:M ratio. Systems displaying this type of crisp white foam produce an excellent settling sludge and leave a very low effluent BOD and TSS.

### **CHANGES IN INFLUENT FLOWS AND CHARACTERISTICS**

Although it is typical for large municipal wastewater treatment plants to receive very stable hydraulic and organic loadings, other systems are faced with plant loadings that change on a day-to-day basis. Of all of the secondary treatment systems, activated sludge is particularly ill suited to deal with this problem. One of the reasons that this is true is that filamentous bacteria are always potentially ready to exploit changes in the system. Filamentous bacteria are very strong competitors and are usually able to exploit changing conditions, whereas all of the “good guy” type microbes suffer. For this reason, it is important that operators understand the changes that can occur to the influent characteristics and flow rate that can affect their plant. The following details the common problems encountered in this regard.

#### **Variable Hydraulic and Organic Loadings**

Some systems do not receive the same waste load everyday. A good example of this is a small package plant that serves a school. The hydraulic and organic loading in this situation is highly variable. On the weekends and during the summertime, there may be little or no flow to the treatment plant. However, just as the F:M ratio can be described in terms of the feeding rate for your pet dog, the problem of variable loading can be explained in these terms as well. Would your dog be happy to receive no food over the weekend or all through the summer? Probably not! The organisms in a activated sludge wastewater treatment facility are not different. In this situation, it may become necessary to “feed” the plant a substitute food source for the times when there is no influent flow. Coincidentally, many small treatment plant operators actually use commercially purchased dog food as a way of supplementing the loading to their systems’. Rabbit food offers an even better alternative, because it does not contain the fats that are present in high amounts in dog food.

Because the hydraulic loadings may be received in short bursts as opposed to being spread evenly throughout the day, flow equalization is often necessary. This is not always taken into account by the system’s design engineer, and so the operator is left to make due.

#### **Recycled Solids**

Several recycle flow streams occur in treatment plants that must be accounted for if the loading to the system is to be

accurately understood. Liquid from digesters, thickeners and dewatering processes are generally routed back to the head of the treatment plant. Depending on the source, these recycle streams can have very high TSS and BOD content and may have extreme levels of ammonia or nitrate. The liquid that is decanted out of anaerobic digesters can often have a BOD in excess of 1,000 mg/L and ammonia concentrations over 100 mg/L. When this waste is reintroduced into the treatment system, it adds a substantial load that must be considered.

The liquid that results from aerobic digester supernating can often be heavily laden with filamentous bacteria. Supernating under these conditions can actually result in the creation of a filamentous bacteria induced sludge bulking problem. Chlorination of the supernatant prior to feeding it back into the plant can be used to control this problem. The liquid stream from centrifuges and belt presses can be very high in TSS and BOD if the thickening/dewatering process is not functioning properly. All of this must be considered by the operator when assessing the system's loading.

### **Storm Events**

Many treatment facilities in New Mexico experience increased influent flows during storm events due to the inflow of storm water from streets and low lying areas. Storm flows often sweep excessive dirt and silt into the plant. This can result in a rapid increase in the MLSS concentration in the aeration basin, but the concentration of the MLVSS will remain the same. Although the dirt and silt contributes to the total amount of MLSS, it is generally all inert matter that does not help to metabolize the organic waste load. This problem is often accompanied with high TSS in the effluent, but no elevation in the effluent BOD. Solids increase drastically but the percent of volatile solids may drop to 50%. Although this inert matter must be wasted out of the system, it must be performed in a controlled manner to prevent too drastic of a decrease in the microorganism population.

### **Temperature Changes**

Temperature changes affect activated sludge systems in a variety of ways. The activity of microorganisms slows with colder temperatures. Because of this, operators often have to adjust to cold conditions by increasing the overall mass of microorganisms in the aeration basin just to accomplish the same level of treatment. Filamentous bacteria tend to take advantage of temperature changes that change the growth rate of other organisms. At the onset of winter, filamentous bacteria are less affected by the cooling temperatures and therefore experience less of a growth reduction than other organisms. At the onset of summer, they are prone to experience a growth spurt much sooner than the other organisms. For this reason, many plants

experience filamentous bacteria related problems during seasonal temperature changes in the spring and fall.

The ability to dissolve oxygen is also affected by temperature. Water will dissolve more oxygen when it is cold than when it is warm. This means that the aeration system will be working its hardest during the hot summer months. During the cold months of the winter, it may be necessary to reduce the amount of aeration. (This is also a good way to save energy).

### **Toxic Discharges**

All plant operators should be alert for the possibility of toxic dumps, accidental spills (particularly the midnight variety), storms, or other collection system activity that may change the influent flow or waste characteristics. Toxic discharges can be introduced into the sewer intentionally and unintentionally. The variety of potential toxic substances is enormous. Operators have only a little control over toxins once they enter the treatment plant. Occasionally, there will be a spare basin available where the toxic influent can be directed in order to prevent the total die-off of the plant (provided the spill is identified early). If the organisms are killed off, preparations should be made as soon as possible to re-seed the aeration basin with healthy organisms from another plant. Be sure that the toxic substance has been completely removed or neutralized before re-seeding. Some toxic discharges occur out of the blue, while others happen on a regular basis.

Operators can work with their industrial discharges to prevent large toxic discharges from damaging the plant. Often, industrial dischargers can be convinced to release strong or toxic wastes at a low discharge rate rather than all at once. Certain industries such as canneries create seasonal problems, which the operator should prepare for in advance. Septage is one category of waste that many treatment facilities struggle from. Septic tanks are common throughout New Mexico, but dedicated septage receiving stations are not. This means that septage tank sludge is often dumped into wastewater facilities for treatment. Depending on the facility size and condition, septic waste can cause great harm to activated sludge systems. Of particular concern is that septic discharges encourage the growth of filamentous bacteria, such as type 021N, that are responsible for serious filamentous bulking problems.

### **Changes in Sampling Program**

Data on system performance can be greatly affected by changes in a sampling program. If improper sampling locations or laboratory procedures are used, lab results could vary considerably. When the lab data varies widely from one day to the next, check sampling location, time, and lab procedures for errors. Remember that when considering a major process change first review the plant data. Make only one major change at a time. If two changes

are made concurrently, it is impossible to determine which change was responsible for which outcome. Allow one week for a plant to stabilize after a process change. An experienced operator who knows the plant may be able to determine if the proper changes have been made after several days, but some plants require up to one month to stabilize after a change. A good rule of thumb to follow is not to change any process parameter more than ten percent per week.

### RESPONDING TO PLANT CHANGES

One of the most useful tools that will help when it is time to respond to changing conditions within the treatment plant is a complete and accurate record of the operating history of the plant. Most plants go through seasonal variations. Once the proper response has been figured out, it can be applied successfully each year.

Usually each plant will have some mixed liquor suspended solids concentration where the plant will function best at particular times of the year. As the plant grows older, the loading typically increases and operators will have to respond to this. As the years go by, most operators learn the likes and dislikes of their plant very well.

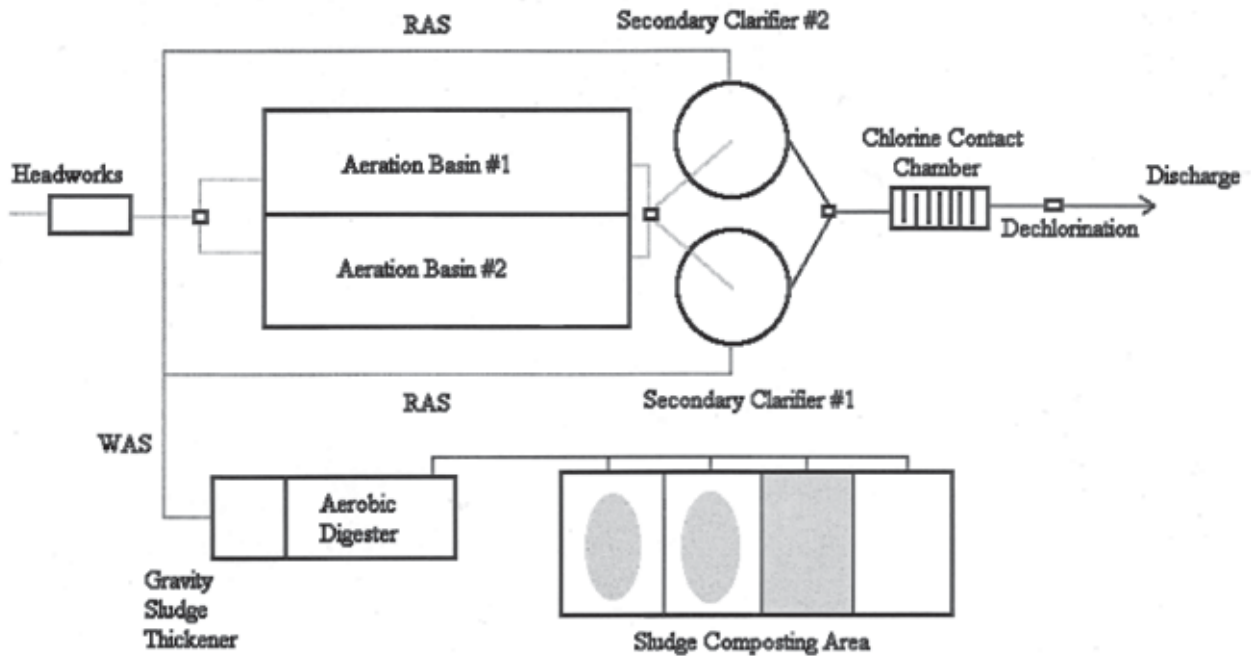
### References

- Office of Water Programs, California State University, Sacramento, *Operation of Wastewater Treatment Plants*, Volume II, 4<sup>th</sup> ed., Volume I, Chapters 5 & 8
- Office of Water Programs, California State University, Sacramento, *Operation of Wastewater Treatment Plants*, Volume II, 4<sup>th</sup> ed., Volume II, Chapter 11
- Office of Water Programs, California State University, Sacramento, *Operation of Wastewater Treatment Plants*, Volume II, 4<sup>th</sup> ed., *Advanced Waste Treatment*, 4th ed., Chapter 2
- Manual on the Causes and Control of Activated Sludge Bulking and Foaming, 1<sup>st</sup>, 2<sup>nd</sup> and 3<sup>rd</sup> ed.
- 

### PRACTICE PROBLEM SET

The diagram on the following page represents an extended aeration activated sludge plant operating in New Mexico. Using the data given, attempt to answer the following questions:

- 1) This treatment plant is running at:
  - A. A high F:M
  - B. A low F:M
  - C. A correct F:M
- 2) What could an operator do to improve the treatment process?
  - A. Raise the MLSS concentration
  - B. Lower the MLSS concentration
  - C. Take one aeration basin off line
  - D. Take one clarifier off line
- 3) Is anything else wrong with the secondary treatment process?
  - A. RAS flow too high
  - B. Wasting too much
  - C. SVI too high (bulking)
- 4) What is the cause of the Fecal Coliform violation?
  - A. Chlorine dose is too low
  - B. Sulfur dioxide dose is too low
  - C. Dechlorination contact time too low
  - D. Dirty chlorine contact chamber
- 5) How well is the gravity sludge thickener working?
  - A. Good, for a gravity thickener
  - B. Adequately
  - C. Poorly
- 6) What impact will this have on the sludge composting operation?
  - A. None
  - B. Increase compost time
  - C. Decrease compost time



This plant discharges to a river under a federal NPDES discharge permit with the following limits:

Parameter	30-day Average	7-day Max	Loading
Flow	Report	Report	NA
BOD	30 mg/L	45 mg/L	250 lbs./day
TSS	30 mg/L	45 mg/L	250 lbs./day
Fecal Coliform	< 500 CFU/ 100ml	500 CFU/ 100ml	NA
pH	6 - 9	NA	NA
TRC	No-Measurable	No-Measurable	NA

The treatment plant data is as follows:

Influent	Aeration Basin	Secondary Clarifiers	Chlorine Contact Chamber	Dechlorination	Effluent
Q = .355 MGD	Vol. = 0.75 MG (each)	Vol. = .15 MG (each)	Vol. = .065 MG	SO <sub>2</sub> Dose = 12 lbs./day	Q = .455 MGD
Peak Factor = 3.5	MLSS = 2000mg/L MLVSS = 1300mg/L	Sludge Blanket = 1ft. in 16 ft. water depth	CL <sub>2</sub> Dose = 20lbs./day		BOD = 28mg/L TSS = 28mg/L
BOD = 165mg/L TSS = 175mg/L	Settleometer = 250 ml/L in 30 min.	RAS Q = 350 gpm	Solids Deposition = 6"		pH = 7.5
pH = 7.6	D.O. = 1.5 mg/L	RAS Concentration = 1.5 %			TRC = No-Measurable
Color and odor normal	Dark brown scum blanket on surface	WAS Q = 0.02 MGD			Fecal Coliform = 1700 CFU/100 ml
<b>Sludge Thickener</b>	<b>Aerobic Digester</b>	<b>Composting Area</b>			
Vol. = 0.1 MG	Vol. = 0.25 MG	60,000 sq.ft.			
Thickened Sludge TS = 1.6%	D.O. = 1.0 mg/L	Compost Generated Annually = 50 metric tons (dry weight)			



# CHAPTER 11: SOLIDS HANDLING

---

## SOLIDS HANDLING PROCESSES

When a wastewater treatment plant is operating properly, most of the solids in the wastewater will be removed at the plant while the water itself will be discharged as effluent to the receiving waters. These solids, known as sludge, must be *stabilized* and reduced in volume before they can be re-used or disposed of economically and safely. The processes used to stabilize sludge and reduce its volume are known as solids handling. Solids handling incorporates four functions; thickening, digestion, dewatering and sludge disposal/ re-use.

### DIGESTION

The sludge produced by wastewater treatment processes can be highly variable. Sludge from the secondary clarifiers of a treatment process such as extended aeration activated sludge is already partially stabilized while the sludge produced by primary clarifiers is unstable, odorous and full of pathogenic bacteria (raw). Solids must be thoroughly stabilized in order to avoid problems such as odors, human exposure to pathogenic organisms and attraction of vectors (mice, dogs, birds). Although stabilization can be done chemically and thermally, biological digestion is the process most often used to stabilize sludge generated by wastewater treatment plants. We can think of digestion as “breaking down” sludge into simpler components through the action of microorganisms. During digestion, a portion of the sludge is converted to gasses such as CO<sub>2</sub>, methane and water vapor. This reduces the volume of the sludge and, more importantly, reduces the volatile solids content. It is through a reduction in volatile solids content that the sludge is stabilized during digestion. Digestion can take place under aerobic or anaerobic conditions.

### ANAEROBIC SLUDGE DIGESTION

Anaerobic digestion converts wastewater solids such as primary sludge, secondary sludge and scum into a substance that is relatively odor free, dewaterable and capable of being disposed of without causing serious problems. Pathogens are greatly reduced when the process is operated correctly. Anaerobic digestion can also reduce the volatile content of the sludge by 30 – 60% and produce valuable methane gas as a by-product.

### How Anaerobic Digestion Works

Anaerobic digestion relies upon the actions of two groups of bacteria living together in the same environment. One group consists of SAPROPHYTIC organisms, commonly referred to as the “acid formers”. The second group, which uses the acid produced by the saprophytes, is the “methane fermenters”. The methane fermenters are not as abundant as the acid formers in raw wastewater, in part because they

only reproduce in a pH range of 6.6 to 7.6. The key to anaerobic digestion lies in balancing the rate of acid formation with the rate of methane fermentation. If the rate of acid formation is higher than the rate of methane production, the pH will begin to fall below the area that favors the methane formers.

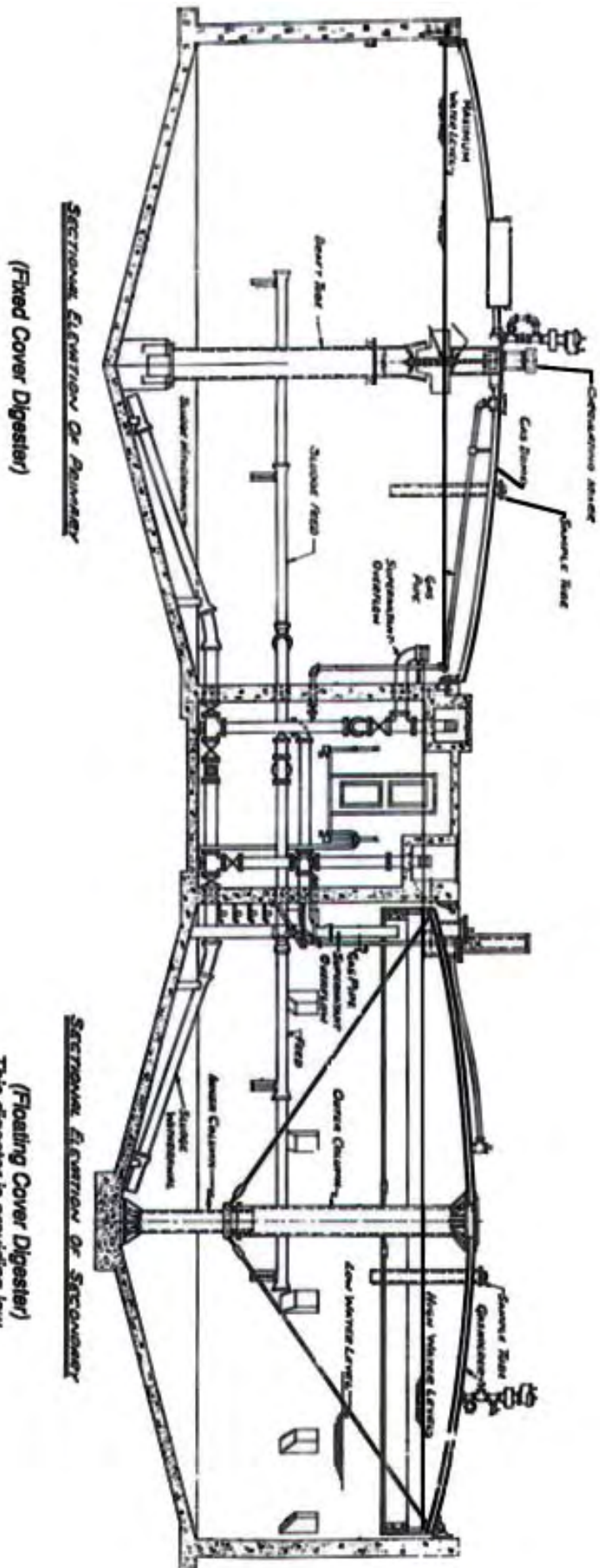
Anaerobic digestion can occur within three distinct temperature ranges. The temperature range affects the rate at which digestion will go forward. At the lowest temperature range, (10 - 20° C), PSYCHROPHILIC, cold temperature loving, bacteria will predominate. Digestion at this temperature is slow and inefficient. Examples of digesters that operate in this range include; Imhoff tanks, septic tanks, unheated unmixed digesters and the anaerobic portion of lagoons. Carbon dioxide, hydrogen sulfide and water are the predominate by-products of this type of digestion. Only a little methane fermentation happens in this temperature range.

In the middle temperature range, (20 - 45° C), MESOPHILIC, medium temperature loving, bacteria will thrive. This is the most common temperature range for anaerobic digesters in use at wastewater treatment plants because it produces a high level of methane production with a short digestion time (normally around 25 – 30 days). The ideal temperature is about 35° C, (95° F), so digesters of this type are typically heated, often through combustion of the methane gas that they produce as a by-product. Mixing is included in this type of digester to ensure that the temperature is maintained evenly throughout and bacteria and food can come into contact with each other.

The highest temperature range, (49 - 57° C), is dominated by THERMOPHILIC, hot temperature loving, bacteria. Because of problems maintaining the high temperature, sensitivity of the organisms to temperature change and reported poor liquid/ solids separation, few digesters run in the thermophilic range.

It is important to note that you cannot simply raise the temperature of a digester and have a successful operation in another range. The organisms take time to adjust to the new temperature. A good rule to follow for anaerobic digestion is never change the temperature more than one degree (Fahrenheit) a day to allow the organisms to become acclimated.

Anaerobic digesters in New Mexico are typically two stage, (primary and secondary), operating in the mesophilic temperature range. The first stage is heated and



**(Floating Cover Digester)**  
 This digester is providing low pressure (less than 8 inches of water column pressure) gas storage for both digesters.

Figure 11.1 - Anaerobic Digester Components

mechanically mixed. Up to 90% of the gas production occurs in the primary digester while the second stage is used for storage and solids/liquid separation. Mixing is usually provided for the second stage, but only used periodically. Supernatant is sometimes drawn from the secondary digester and returned to the treatment plant to make room for more sludge. The secondary digester also serves as a source of *seed* organisms for the primary digester in case it becomes upset.

### **Pipelines and Valves**

The pipe used in anaerobic digesters must be able to withstand pumping pressures and severe corrosion. Cast iron or steel is typically used. Plug valves are commonly used in sludge and scum lines. Gate valves or butterfly valves are undesirable and rarely used because grease, rags and debris can catch on them and prevent them from seating.

### **Anaerobic Digester Tank**

Most modern anaerobic digesters are cylindrical in shape, around 20 ft deep and have sloped floors so that sand, grit and heavy sludge will be removed during sludge withdrawal.

### **Sludge Feed (inlet) Line**

The sludge feed line is typically piped to the top of the primary digester on the side opposite from the supernatant overflow pipe or injected into the sludge recirculation line upstream of the heat exchanger.

### **Supernatant Tubes**

Typically, some method of removing supernatant from several levels in the digester is provided. This can be a valved manifold on the side of the digester or an adjustable tube inside the digester. The purpose is to allow the removal of the lowest solids content supernatant. The supernatant is then returned to the primary clarifiers in controlled amounts (to avoid upsetting the treatment plant). However, the practice of supernating can be undesirable because of the high amount of BOD and ammonia returned to the treatment plant in the supernatant stream.

### **Sludge Draw-Off Lines**

Sludge draw-off lines are usually placed on blocks inside the digester. It is preferable not to locate them under the floor of the digester because they would not be accessible in case of blockages. These lines are normally at least six (6) inches in diameter and equipped with plug valves. The lines are used to transfer seed sludge from the secondary to the primary digester, to remove sludge to a drying bed or other dewatering unit or to recirculate bottom sludge and break up scum blankets.

### **Mixing System**

Digesters can be mixed by several method. Mechanical mixers that utilize propellers and draft tubes are common. Mixers that work by compressing and bubbling methane gas into the sludge are also used.

### **Gas System**

MESOPHILIC anaerobic digestion produces 8 – 12 cubic feet of gas for every pound of volatile matter *added* and 12 – 18 cubic feet for every pound of volatile matter *destroyed*. The gas consists mainly of methane (CH<sub>4</sub>) and carbon dioxide (CO<sub>2</sub>). The methane content will vary from 65 – 70% while the carbon dioxide content will vary from 30 – 35%. Digester gas contains a heat value of 500 – 600 BTU per cuft. (Natural gas contains 900 – 1200 BTU per cuft). Digester gas can be re-used in various ways such as; heating the digester, driving an engine/generator and heating plant buildings. The gas system for a digester serves to remove the gas to a point of use, provide safety features and burn off excess gas in a waste gas burner. The main components of the gas system include; the gas dome, pressure and vacuum relief valves, flame arresters, thermal valves, sediment traps, drip traps, gas meters, manometer, pressure regulators, and the waste gas burner.

### **Digester Heating System**

A boiler fired off of digester gas, natural gas or propane typically provides the heat for the digester. Boiler water is best maintained at between 60 and 82° C. Two methods of heat exchange are common; sludge recirculation through an external heat exchanger or heat exchangers located inside the digester.

### **Floating Cover**

Many digesters are equipped with floating covers, (most commonly located on the secondary digester) to provide a flexible space for digester gas storage. A properly designed floating cover can also keep the scum blanket mixed in with the digesting sludge, which will prevent the blanket from becoming excessive. Floating covers can move up and down as the level of gas and sludge increases or decreases. The interior of the digester is sealed off from the atmosphere by a sludge seal located between the annular space between the cover and the digester wall. If the level of sludge in the digester is allowed to drop low enough, the seal will be broken and an explosive mixture of methane and oxygen could develop. Explosions have occurred when an inattentive operator withdrew too much sludge from an anaerobic digester with a floating cover. **EXTREME CAUTION MUST BE USED TO PREVENT AN EXPLOSION WHENEVER AN ANAEROBIC DIGESTER IS EMPTIED OR DEWATERED FOR MAINTENANCE OR CLEANING.**

### **Sampling Well**

The sampling well consists of a 3 or 4 inch diameter pipe (with a hinged sealing cap) that extends down through the gas layer, at least one foot into the digesting sludge. The sampling well permits samples to be taken of the sludge without dangerously exposing the gas to oxygen. Be aware that some gas will always be present when the sampling well is first opened. Sampling wells are sometimes referred to as “thief holes”.

### **OPERATION OF ANAEROBIC DIGESTERS**

As stated earlier, the key to operating an anaerobic digester lies in balancing the acid formation and methane fermentation processes. This is accomplished by maintaining the desired temperature (95° F), ensuring mixing to promote contact between the organisms and the food as well as promoting even heating. Of high importance is FEEDING AND WITHDRAWING SLUDGE AT PROPER RATES. It is a good rule of thumb not to withdraw more than 5% of a digester’s content in a 24 hour period.

The type of sludge being digested is important. Raw sludge from a primary clarifier typically contains around 4 – 5% total solids, of which 70 – 90% is volatile matter. On the other hand, waste activated sludge can range from 0.2 – 6% total solids (high end due to thickening) with 65 – 75% being volatile. Raw sludge digests rapidly while waste activated sludge digest slower and less thoroughly, in part because of its lower volatile solids content at the beginning. Care must be taken to balance the feeding of raw sludge and secondary sludge in order to avoid upsetting the digester.

Feeding sludge to a digester is best done several times a day rather than all at once to avoid lowering the temperature of the digester too far at one time. Pumping several times a day not only helps the digester but also help the clarifiers by avoiding holding sludge in primaries for too long and ensuring a consistently thick sludge. Every effort to pump as thick of sludge as possible should be made. This is because digester space is at a premium and sludge that contains too much water may dilute the *buffering* capacity of the digester. Buffering capacity refers to the digester’s ability to neutralize the organic acids that are being produced by the acid formers. Buffering capacity depends on the amount of alkalinity contained in the sludge within the digester. If a digester does not contain enough buffering capacity, the pH of the sludge will drop. This harms the methane formers because they can only reproduce in a pH range of 6.6 to 7.6. If the pH falls too far, methane production will taper off and the digester is said to be “sour” or “stuck”.

Several tests are used to monitor the condition of the digestion process. These are;

- Temperature. A thermometer is usually located in the sludge recirculation line from the digester to the heat exchanger. A temperature of between 95° and 98° F should be maintained. Never change the temperature more than 1° F per day.
- Volatile Acid/ Alkalinity relationship (VA/Alk ratio). As long as volatile acids remain low and the alkalinity (buffering capacity) remains high, the digestion process will remain stable. Each treatment plant has its own acceptable ratio of volatile acids to alkalinity. However, this ratio is usually less than 0.1 part volatile acids to each 1 part alkalinity (10 times as much alkalinity as volatile acids). A CHANGE IN THE VA/ALK RATIO PROVIDES THE FIRST INDICATION THAT SOMETHING IS WRONG WITH THE DIGESTER. For this reason it is imperative that the VA/Alk ratio be monitored at least weekly.
- Digester Gas Content (CO<sub>2</sub> and methane). The percentage of CO<sub>2</sub> in the digester gas is an indication of digester performance, however, the VA/Alk ratio will change before the CO<sub>2</sub> content begins to increase. Good digester gas will have 30 – 35% CO<sub>2</sub> and 65 – 70% methane. If the CO<sub>2</sub> content exceeds 42%, the digester is considered to be in poor condition. If the content of CO<sub>2</sub> is greater than 45%, the gas will not burn.
- pH. pH readings are normally taken on raw sludge, recirculated sludge and supernatant. Because the VA/Alk ratio will show changes long before the pH actually changes, pH measurements should be used for recording purposes but not for process control. A pH of 7.0 – 7.6 indicates good operations.
- Solids Content. The total solids should be determined for the feed sludge(s), the recirculating sludge, withdrawn sludge and supernatant. A TS content of 3 – 6% is typical for sludge in the digester. Volatile solids reduction of the sludge is a key indicator of digester performance. Volatile solids reductions of 50 – 60% are not uncommon.

### **TROUBLE SHOOTING ANAEROBIC DIGESTER PROBLEMS**

Careful process control and an understanding of the fundamentals will help operators avoid most anaerobic digestion problems. However, problems do arise. Table 11.1 shows common anaerobic digester problems, key process control indicators and possible solutions.



**Table 11.1 - Troubleshooting Anaerobic Digester Problems**

PROBLEM	KEY INDICATOR	POSSIBLE CAUSE	POSSIBLE SOLUTION
Digester "Souring"	VA/Alk >0.1 : 1 pH 7.0 – 7.2	Excessive feeding of raw sludge, sludge withdrawal rate too high, shock-load	Recirculate secondary digester sludge to primary digester to increase alkalinity and seed desirable organisms.
Digester "Stuck"	VA/Alk >0.5 : 1 pH <7.0 and dropping	Not correcting a "souring" digester	Add alkalinity in the form of lime, soda ash or sodium bi-carbonate to neutralize the excess organic acids.
Foaming	Large amounts of foam	Start-up period, breakup of scum blanket, radical temp. change or over feeding	Increase mixing, stop or decrease feeding, stabilize temp.
Low methane production	CO <sub>2</sub> >40%	Start-up period or uneven control of temperature	Stabilize temp., control feeding rate and withdrawal rate.
Large amount of solids in supernatant	TSS > 1000mg/L	Drawing from wrong level	Draw from correct level. <b>NOTE:</b> supernatant is often very high in solids even after settling for several days.

**AEROBIC SLUDGE DIGESTION**

Another method of biological sludge digestion is one that takes place in an aerobic environment. Aerobic digestion is quite different from anaerobic digestion. In fact, aerobic digestion is essentially just an extension of secondary treatment processes. Air and mixing are provided to solids held in a tank, but no artificial heating takes place. Because no *food source* is provided to the organisms in the tank other than more organisms (sludge), they devour each other. (This is known as *ENDOGENOUS* respiration). The cycle of organism eating organism breaks down the sludge and releases CO<sub>2</sub> and water vapor. Aerobic digestion is not as efficient as anaerobic digestion. Volatile solids reductions of 20 – 40% are typical with solids detention times of around 20 – 30 days. If the solids are digested for a longer period, the volatile solids reduction can be slightly higher but rarely approaches anaerobic digestion rates. Because of predation from a wide variety of organisms, the level of pathogens in aerobically digested sludge is significantly lowered.

**COMPONENTS OF AEROBIC DIGESTERS**

Aerobic digesters, due to their simplicity, consist of only a few components. This makes the process attractive to small to medium sized treatment plants. Aerobic digesters are often included in "package plants" and medium sized extended aeration activated sludge plants and SBRs because of the readily available supply of air for aeration.

**Digester Tank**

Aerobic digesters can be round, square, rectangular or any shape that suits the design engineer's needs. The tanks are usually constructed of steel or concrete to a depth of at least 10 ft. The material used to construct the tank should be protected from corrosion to at least the same level of protection provided for the secondary treatment process.

**Aeration System**

Aerobic conditions must be maintained in the digester at all times or odors will develop. The aeration system should be capable of maintaining a minimum of 1.0mg/L dissolved oxygen concentration at all times.

Aeration can be accomplished with floating surface aerators, fixed bridge aerators or blowers using coarse bubble diffusers. Some flexibility to alter the level of aeration and mixing should be provided. (It is often desirable to be able to apply more air to the treatment process and less to the digesters when needed). If diffusers are used, some provision for retrieving them for cleaning should be included.

**Sludge Inlet and Outlet Lines**

Cast iron, ductile iron or steel lines are usually provided for the sludge inlet and outlet lines. The sludge inlet should be located above the high water level of the digester tank. The outlet line should be located at the bottom, or preferably in a slightly sunken sump in the digester floor to allow the tank to be completely emptied for cleaning (this is rarely the case). No matter how small the treatment plant, sludge lines should be a minimum of 3 inches in diameter to prevent plugging from grease, rags, etc.

**Supernatant Tubes**

Some aerobic digesters are equipped with supernatant tubes. Shutting off the aeration system for several hours will cause sludge will settle to the bottom of the digester. Using supernatant tubes, clarified liquid can be drawn off and returned to the head of the treatment plant. Supernating from aerobic digesters is not always a good practice. Aerobic sludge does not usually settle well and leave a clear supernatant (without the use of settling aids). Worse, if the digester aeration system cannot maintain at least 1.0 mg/L, the supernatant itself can be a source of *filamentous*

organisms that can upset activated sludge treatment processes when returned to the plant influent flow.

### OPERATION OF AEROBIC DIGESTERS

There is not much involved in the operation of aerobic digesters. Sludge feed rates are based on the need to remove solids from the secondary treatment process. Sludge removal rates are determined by the level in the digester and by the availability of sludge dewatering and drying units. Around 1.0 mg/L D.O. should be maintained or the digesting sludge can produce a “rotten melon” odor that becomes progressively more offensive. Aerobic digesters should be taken off-line and completely cleaned at least once every three years in order to preserve the tank volume (remove sediment) and inspect submerged equipment. Monitoring tests that should be done at least weekly include;

- pH. The pH of the digesting sludge should be determined and recorded. The pH of aerobic digester sludge should always be above 7.0. If it is not, a problem in the secondary treatment process is indicated. An example would be un-wanted nitrification causing acidic conditions in waste activated sludge. A source of alkalinity such as lime may have to be added to the digester in this situation to maintain a neutral pH.
- Total Solids. The TS of the feed sludge, digesting sludge and of sludge withdrawn from the digester should be known. TS in aerobic digesters typically range from 1.5 – 4%.
- Volatile Solids. The volatile solids content of the feed sludge, digesting sludge and sludge withdrawn from the digester should be known. The reduction of volatile solids through the digester gives a measure of the effectiveness of the digestion process. Over time, the volatile solids reduction will decrease. This is due to sediment that reduces the digester’s volume (resulting in a lower digestion detention time). If the volatile solids reduction falls to unacceptable levels, cleaning of the digester to restore detention time is indicated.
- Dissolved Oxygen. D.O. in the digester should be measured with a calibrated D.O. meter. In order to avoid serious odor production, at least 0.5 mg/L of D.O. should be maintained.

### CHEMICAL SLUDGE STABILIZATION

Sludges which are not biologically digested can be made stable by the addition of large doses of lime. THE ADDITION OF LIME TO SLUDGE TO PREPARE IT FOR ULTIMATE DISPOSAL IS NOT A COMMON PRACTICE. Chemical stabilization is usually considered a temporary stabilization process and finds applications at overloaded plants or at plants experiencing digestion facilities upsets. The main drawbacks to chemical

stabilization are the cost associated with the large quantities of chemical required and the quality of the end product.

Lime stabilization is accomplished by adding sufficient quantities of lime to the sludge to raise the pH to 11.5 - 12.0. This extremely caustic condition kills virtually all organisms in the sludge, thus preventing biological changes (temporarily) and killing off pathogenic organisms such as bacteria, viruses and parasites.

The best way to determine the amount of lime required to raise the pH of a particular sludge to within the desired range is to perform a bench scale test using 1 – 2 liters of sludge and then calculate the volume needed for full scale based on the results. An important drawback to lime stabilization of sludge is that, unlike other stabilization processes, the overall mass of solids is not reduced. In fact, it increases.

### SLUDGE THICKENING AND DEWATERING PROCESSES

Even what is considered a “thick” sludge, (5 – 6% total solids), still contains over 90% water. Storing and transporting all the water along with the solids contained within it is not practical. For this reason, there are a number of methods of separating solids from water. These methods include; gravity thickeners, diffused air floatation (DAF) units, belt presses, centrifuges and sludge drying beds. Some of the methods are capable of thickening sludge, but it remains a liquid. Others can remove enough water that what is left is a semi-dry to dry solid. Some dewatering processes are located before digestion, others after. Most drying processes, like sludge drying beds, are only practical if located following digestion. Chemicals that are known as **polymers** can be used to enhance many of the sludge dewatering and drying processes.

### GRAVITY THICKENERS

Gravity thickening of wastewater sludge uses the force of gravity to separate solids from water. Solids that are heavier than the water will settle to the bottom and be compacted by the weight of the overlying solids. Gravity thickeners are typically circular or square in design and resemble secondary clarifiers. Their main components include; a feed line and baffle for good flow distribution, a sludge rake mechanism to move the sludge to the bottom center of the tank for removal, vertical steel “pickets” mounted on the sludge rake, an effluent overflow weir, a scum box or tilting weir for removal of floating scum and solids, and a sludge withdrawal line.

The successful operation of gravity thickeners depends upon these factors:

1. Type of sludge being thickened. Primary sludge thickens best in gravity thickeners, but must not be allowed to become septic. Secondary sludge can be difficult to thicken in this type of process due to their lower solids content and denitrification.
2. Age of the feed sludge. Older sludges are prone to *gasification* caused by denitrification and gasses produced by septic conditions that cause sludge particles to float.
3. Sludge temperature. Warmer sludge does not settle as well because of gasification due to the increase in biological activity.
4. Sludge blanket depth. The thickening action is due in large part to the compaction that occurs from the overlying sludge. A balance must be struck between maintaining a thick enough blanket to achieve compaction and removing the solids before gasification.
5. Hydraulic and solids loading. The unit must be designed to handle the hydraulic and solids loading experienced.

Gravity thickeners are typically capable of thickening sludge to between 2 – 4%. Solids concentration as high as 6% can be achieved with the addition of polymers or other thickening agents, but it is important to know whether or not the sludge pump in use can remove concentrations that are this high.

**DISSOLVED AIR FLOATATION (DAF) THICKENERS**

Dissolved air floatation thickening relies on a process similar to what happens to sludge during denitrification. Small air bubbles attach themselves to sludge particles and separate them from the remaining liquid by floating them to the surface where they accumulate into a sludge layer. This sludge layer is skimmed off into a hopper as thickened sludge. A large portion of the separated water is recycled to the feed sludge line after being saturated with air (this provides the bubbles for floatation). Effluent exits the far end of the unit and is returned to the treatment plant flow

stream. Polymers are often used to enhance the separation and thickening characteristics of the feed sludge.

DAF sludge thickener performance guidelines are given in Table 11.2.

The performance of DAF units depends upon the following factors:

1. Type of sludge. Primary sludges are less adaptable to floatation than secondary sludges. Sludge age affects how well secondary sludge thickens. “Young” sludge thickens better than “old” sludge. Primary sludges tend to deposit grit and sediment in the bottom of DAF units so provisions must be made for removal of this material.
2. Air to solids ratio. The amount of air available to float the sludge is critical to the thickening operation. The air pressure in the saturation tank determines the quantity of air actually saturated into the recycle stream.
3. Recycle rate. The recycle flow carries the saturated air to the sludge feed inlet in the DAF tank. When the recycle stream goes from a pressurized condition to atmospheric pressure, numerous small bubbles form as the air comes out of solution (similar to opening a can of soda). Obviously, the higher the recycle rate the more air that is available for floatation. However, the air saturation ratio and the recycle rate are dependent upon one another.
4. Thickness of floating sludge blanket. Adjusting the speed of the surface sludge scrapers can vary the thickness of the floating sludge blanket. Increasing the scraper speed tends to thin out the floated sludge. Conversely, decreasing the scraper speed will tend to result in a thicker sludge. However, the sludge removal rate must be fast enough to prevent solids from carrying over into the effluent. The floating sludge blanket is usually 6 – 8 inches deep. DAF units should produce an effluent that has less than 100mg/L TSS when operating properly.

**Table 11.2 - DAF Sludge Thickener Performance Guidelines**

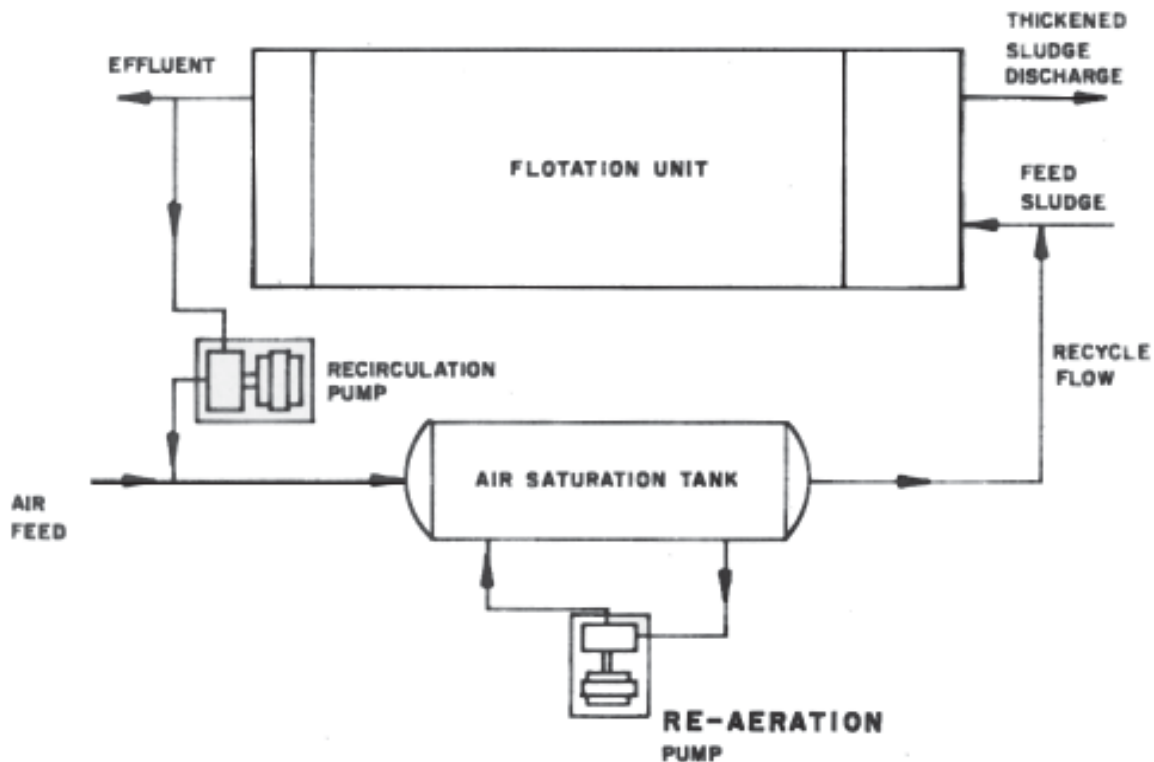
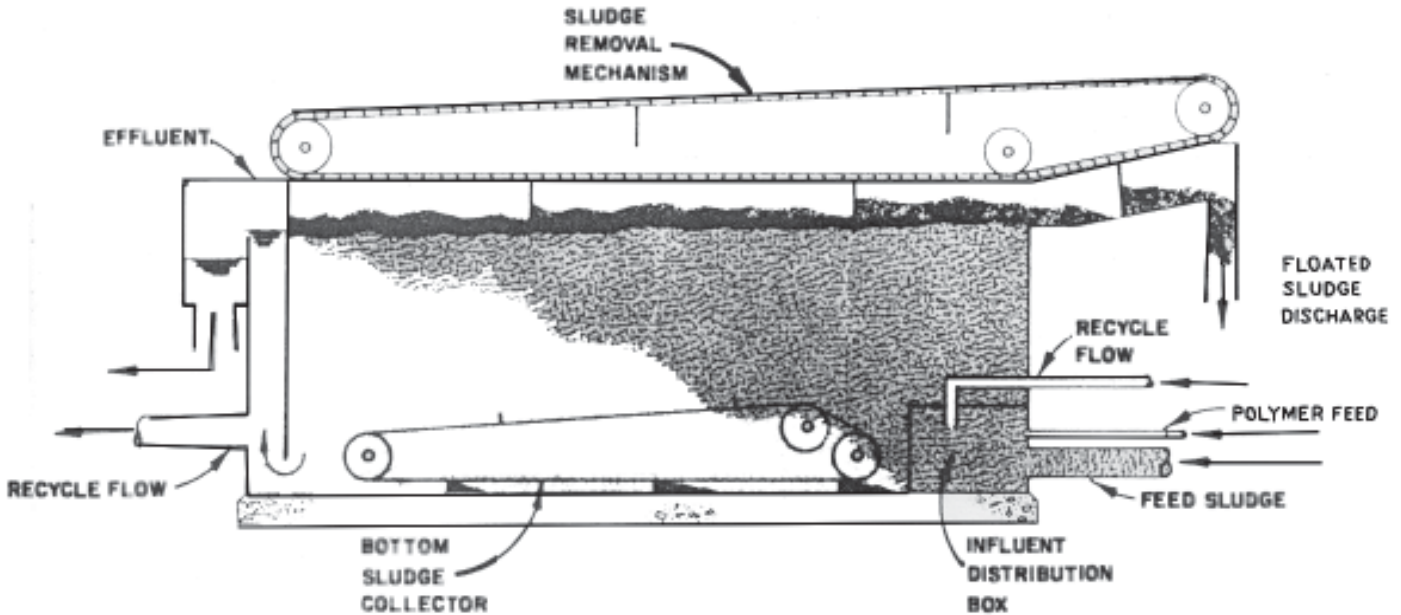
Operating Parameter	Without Polymer Addition	With Polymer Addition
Solids Loading, lbs/hr/sq ft	0.4 – 1.0	1.0 – 2.0
Hydraulic Loading, gpm/sq ft	0.5 – 1.5	0.5 – 2.0
Recycle, %	100 - 200	100 - 200
Air:Solids, ratio	0.01 – 0.1	0.01 – 0.1
Min. Influent Solid Concentration, mg/L	5000	5000
Thickened Sludge Concentration, %	2 - 4	3 – 5



## BELT FILTER PRESS

Belt filter presses consist of two endless belts that travel over a series of rollers assembled on a galvanized steel frame. Sludge is conditioned with polymer and allowed to dewater in a drainage area before it is fed into the area between the two belts. As sludge travels between the belts,

it is pressed between perforated and non-perforated rollers. This causes water to be forced from the sludge and out of the belts where it is collected and returned to the treatment plant. The sludge *cake* is scraped off of the belts and carried away on a conveyor while the two endless belts are washed to prevent plugging.



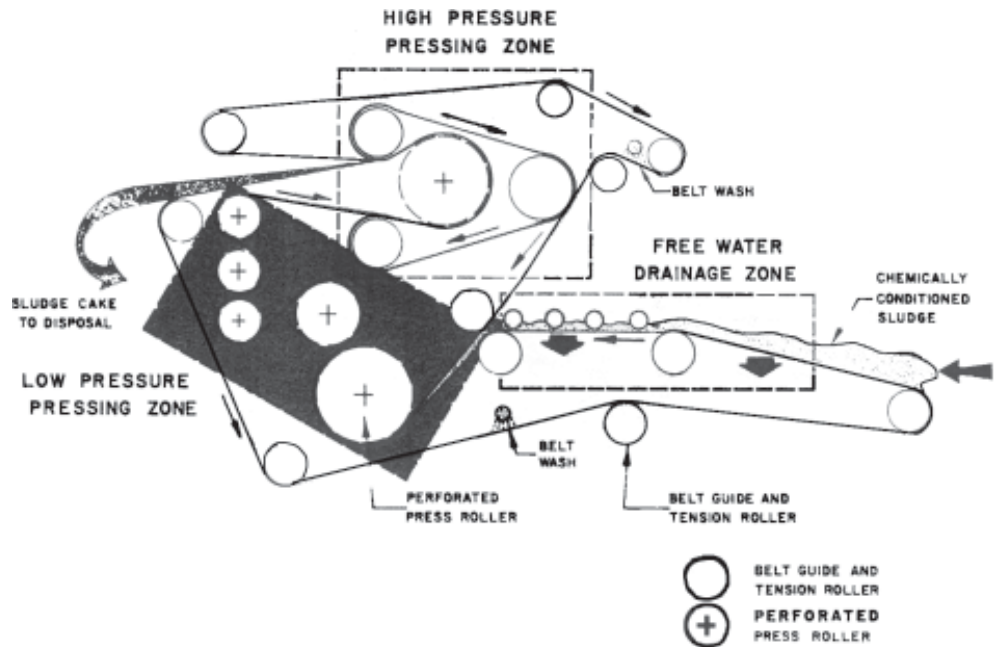
**Figure 11.2 - Typical Dissolved Air Flotation (DAF) Unit**

Reprinted, with permission, from *Operation of Wastewater Treatment Plants*, Vol. III, 2<sup>nd</sup> ed., Office of Water Programs, California State University, Sacramento Foundation



The factors that affect belt filter presses are as follows:

1. Sludge Type. Belt presses are not suitable to all types of sludges. Undigested waste activated sludge generally lacks the qualities necessary for dewatering with a belt press. Undigested WAS is often simply *squeezed* out from between the belts without dewatering. However, if properly digested, WAS can be successfully dewatered using belt presses.
2. Sludge Conditioning. Sludge conditioning prior to passing through the belt press is probably the most critical factor to successful dewatering. Cationic polymers are generally used for conditioning of sludge. Polymer dosages must be optimized to ensure optimal dewatering. A consistent sludge feed is imperative in order to optimize polymer conditioning.
3. Belt Tension Pressure. The pressure applied to the sludge can be increased or decreased by changing the tension roller setting. The belts should be neither too tight nor too loose. Experience will demonstrate the best setting.
4. Belt Speed. The speed at which the belt can be operated depends upon the sludge flow rate and the concentration of influent sludge. The belt speed must be fast enough to spread the sludge over a sufficient area of the belt so that drainage can occur. If not, excess water will be carried along with the sludge being pressed between the belts and the result will be *washout*, which causes the effluent water quality to suffer. The belt speed should be as slow as possible and yet fast enough to avoid washout.



**Figure 11.3 - Typical Belt Filter Press**

Reprinted, with permission, from *Operation of Wastewater Treatment Plants*, Vol. III, 2<sup>nd</sup> ed., Office of Water Programs, California State University, Sacramento Foundation

5. Belt Type. A variety of belt materials are available such as nylon and polypropylene, each with various porosity. Higher porosity belts drain fast but leave a poor quality effluent. Low porosity belts may bind or plug causing frequent washouts. To preserve the life of a belt, belt-cleaning equipment should be kept in good working order.

Belt filter presses generally require close operator attention to attain consistent results. Problems that arise are most commonly associated with feed sludge quality changes and less than optimal polymer dosages, (which are related). The following table outlines the typical performance of properly operated belt filter presses.

**CENTRIFUGATION**

Centrifugal thickening of wastewater sludge is accomplished by subjecting the sludge to high centrifugal forces. Sludge is fed into a rotating bowl. Solids separation occurs due to centrifugal force impelling the solids to the bowl wall where they are compacted. The liquid and fine solids (centrate)

**Table 11.3 - Typical Belt Filter Press Performance**

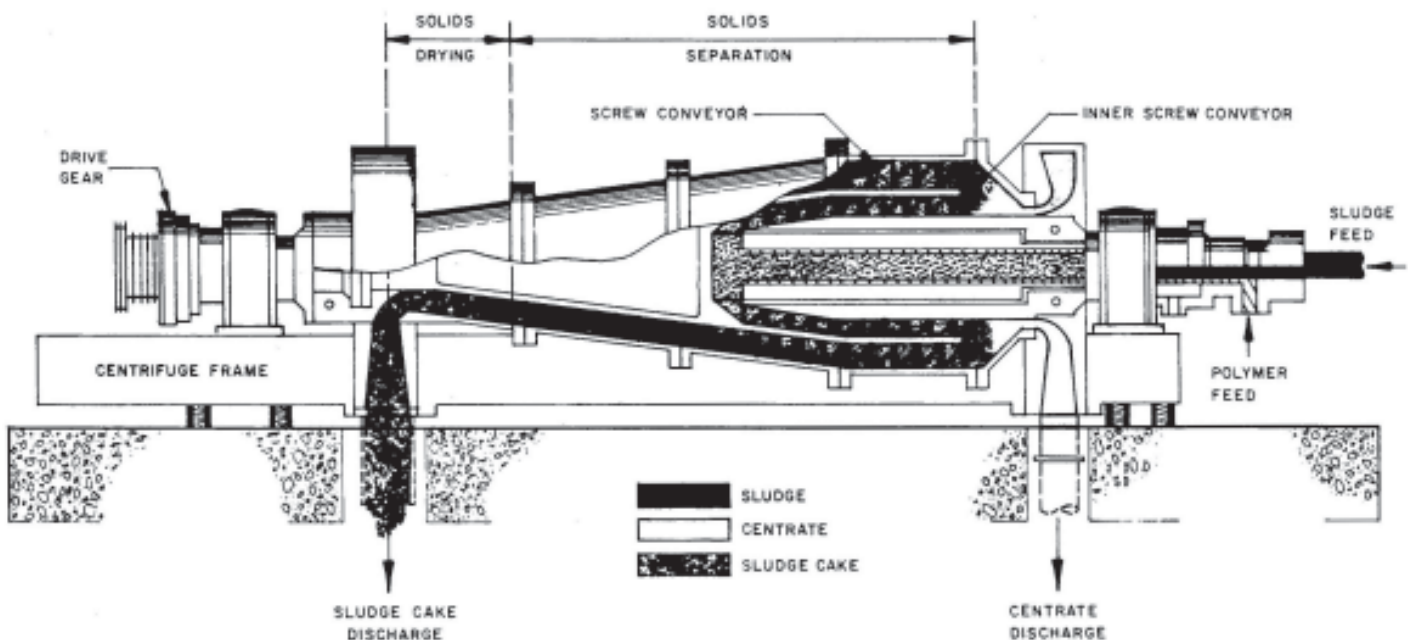
Sludge Type	Polymer, lbs/ton	Cake % TS	Hydraulic Load, gpm/ft*
Primary	4 – 8	25 – 35	10 – 25
Secondary	9 – 20	17 – 20	5 – 15
Digested Primary	4 – 8	25 – 30	10 – 25
Digested Secondary	15 - 30	17 - 20	5 – 15

\* Hydraulic loadings are based on the flow rate applied per unit of belt width. For example, a one-meter belt is approximately three feet wide and so could handle a sludge flow of 30 to 75 gpm.

exit the unit through the effluent line. Thickened sludge is discharged as a liquid or cake. There are several configurations of centrifuges on the market. The most common type of centrifuge in New Mexico is the scroll centrifuge. Scroll centrifuges rotate a tapered bowl along a horizontal axis. An inner scroll is used to evenly distribute the feed sludge. An adjustable weir controls the discharge of the centrate.

The performance of centrifuges is affected by the following factors:

1. Type of Sludge. The type of sludge being thickened is important. Generally, centrifuges are not used to thicken primary sludge because the centrifuge sludge inlets are susceptible to clogging. Secondary sludges are well suited to thickening by centrifugation because they usually lack material that will plug the centrifuge inlets. Centrifuges are less affected than other thickening processes by adverse sludge characteristics such as bulking sludge, rising sludge and old sludge. It should be noted that unlike other sludge thickening processes, off gassing of sludges will occur due to the high separation forces applied. Adequate ventilation is required and consideration must be given to monitoring air quality.
2. Solids and Hydraulic Loading. Unlike gravity thickeners and DAF units, the hydraulic and solids loading of centrifuges is not related to units of area (gpm/sq ft or gpd/sq ft). The accepted loading terminology for centrifuges is gal/hr/unit and lbs./hr/unit. The size of the centrifuge sets the upper limit for solids and hydraulic loadings.
3. Bowl Speed. Increasing the bowl speed will increase the thickness of the sludge cake. However, unless the centrifuge is equipped with a hydraulic back drive, the speed cannot be changed except by changing the drive belt sheaves. Generally, once the ideal speed has been determined for a particular sludge there is no reason to change it.
4. Differential Scroll Speed. The scroll speed will affect the sludge cake thickness and the centrate quality. In general, as cake concentration increases, solids removal efficiencies decrease. Operator observation and experience is the best way to determine the scroll speed setting.
5. Liquid Depth (pool depth). The liquid level in the centrifuge can be varied by adjusting the effluent weirs. A deeper liquid depth results in greater solids capture but a lower thickness sludge cake. A shallower liquid depth results in less solids capture but a thicker sludge cake. Most wastewater sludge thickening operations run will a high liquid depth because solids capture is important to preventing disruption of the wastewater treatment system due to poor quality centrate.
6. Sludge Conditioning. Most centrifuges are operated with polymer addition to improve the thickness of the sludge cake and the solids recovery, which improves the quality of the centrate. Proper polymer dosages, steady sludge feed rates, and internal cleaning of centrifuge for accumulated greases/solids, are important to maintaining centrifuge performance.



**Figure 11.4 - Scroll Centrifuge**

Table 11.4 outlines the typical performance ranges for scroll type centrifuges.

**Table 11.4 - Scroll Type Centrifuge Performance Ranges**

Capacity gpm	% Feed Solids	% Thickened Sludge	% Solids Recovery
20 – 150	<4.0	5 - 30	90 – 99

**SLUDGE DRYING BEDS**

The use of sludge drying beds is usually limited to small to medium sized (< 5.0 MGD) plants in New Mexico due to land and manpower requirements. In the southern part of the state, the abundance of warm weather, sunshine, wind and land makes drying beds a good sludge drying process for many treatment plants. In the northern part of the state, this is not always the case. Sludge drying beds can be divided into three categories; (1) sand drying beds, (2) asphalt or concrete drying beds, and (3) vacuum filter beds.

**Sand Drying Beds**

Sand drying beds consist of shallow lined concrete or earthen basins with perforated pipe installed under a 12 – 18 inch layer of gravel with an 8 - 12 inch layer of sand placed at the top. Decant tubes are located in the corners of the bed to drain any pooled water off of the sludge in the bed. Sludge is poured on the bed to a depth of around 12 inches. Water evaporates from the sludge as well as percolated down through the sand layer and is collected and removed by the perforated pipe under-drain system. When the sludge in the bed has dried to the point that it has cracked all the way down to the sand, the sludge is removed using a shovel and wheelbarrow or a small skid loader. Many older drying beds cannot be cleaned with a skid loader because the under-drains system will be crushed.

The factors that most affect the performance of sludge drying beds are:

1. Climatic Conditions. Little can be done by operators to change climatic conditions. Some sludge drying beds remain frozen throughout the winter and can only be cleared after they thaw and dry out. Rain and snow are less of a detriment to sludge drying than freezing conditions, because dry or partially dry sludge does not take up much water.
2. Depth of Sludge Pour. Sludge should not be poured much deeper than 12 inches because the drying time will increase substantially. Sludge should never be poured onto a drying bed that already contains

partially dry sludge. This practice is known as “capping” and should be avoided because the lower layer of sludge will get sealed off. This lower layer becomes what is called “green sludge”, which is extremely odorous and will not dry.

3. Condition of Sand. The sand should be carefully leveled before sludge is applied to a sand drying bed in order to avoid areas that dry more slowly than the rest of the bed. Older drying beds can become compacted and the sand will not permit water to permeate. If this happens, the best cure is to remove 2 – 3 inches of sand and replace it with fresh, pre-washed sand. Some drying beds use expensive screened and pre-washed sand while others work fine with what could best be described as “arroyo sand”. The best sand has no dirt or clay in it and is free of excessive *finer*, which are very small particles.
4. Use of Polymers. Polymers are often used to improve the performance of sand drying beds. If used properly, polymers can cut the sludge drying time in half. This has the effect of doubling a plant’s number of drying beds.

Sand drying beds are capable of drying sludge to > 95% Total Solids, but 70 – 80% is more typical.

**Asphalt Drying Beds**

Asphalt drying beds are similar in construction to sand drying beds, except that instead of sand and gravel they have a hard asphalt or concrete surface. The hard surface allows the use of sludge mixing equipment to speed the drying time and skid loaders to remove the sludge when it is dried. Decant tubes are an important feature of asphalt beds because pooled water would have to evaporate (taking too much time) if it could not be decanted off. Sludge can be poured to a greater depth (18 – 30 inches) in asphalt beds because the action provided by the mixing equipment will help it dry rapidly. Mixing can be accomplished using an ordinary tractor, backhoe or dedicated sludge mixing equipment like the units manufactured by Brown Bear™ and others. Asphalt beds have proven very successful in dewatering sludge prior to composting, especially in the southern part of the state.

**Vacuum Filter Beds**

Vacuum filter beds offer a relatively new method for dewatering sludge. Vacuum filter beds consist of a shallow concrete basin that has an under-drain system covered over with porous pumice bricks or stainless steel or plastic perforated panels. Sludge that has been conditioned with polymer is poured onto the bed and a vacuum pump is used to create a vacuum underneath the panels. The vacuum rapidly draws water from the sludge. Vacuum beds can



dewater sludge to 15 – 30% TS in a matter of hours or sometimes days. The bed is then cleaned out using a skid loader or small backhoe fitted with a front-loading bucket. Some systems using stainless steel or plastic panels, but without a vacuum pump system, are also in operation in New Mexico.

## **SLUDGE RE-USE AND DISPOSAL**

Because sludge consists of nutrients, organic molecules and trace metals that are needed by plants for growth, it makes an excellent soil conditioner. In fact, in countries such as China, various forms of sludge have been used as a soil conditioner for thousands of years. The general public often expresses concern when the subject of using wastewater treatment sludge as a soil amendment comes up. Many of the public's concerns have a basis in fact and must be addressed. However, some of the concerns are simply "knee-jerk" reactions that can be dispelled with good information. As the operator of a wastewater treatment plant in New Mexico, you may be involved in setting up or running a sludge beneficial use program. If you are, you have two responsibilities; (1) Follow all of the state and federal regulations carefully, and (2) provide a product that is as consistently safe as possible and ensure that it is properly used.

Sludge that has been treated for beneficial use is generally referred to as Biosolids. When applied to soil in the correct amounts, biosolids can greatly improve the soil's ability to retain water as well as improve the aeration of the soil. Because the most prominent soil types in New Mexico are clay and sandy loam, these are tremendous benefits.

If it is not practical to beneficially use all or any of the sludge generated in a wastewater treatment facility, some safe and economical form of disposal will have to be employed.

The alternatives for the beneficial use of biosolids generally involve some form of land application (either distributed in bulk or in bags). Sludge disposal is typically done by surface disposal or landfilling, although incineration is permissible. Be aware that state and federal laws are in place to regulate the use and disposal of all sludge generated by wastewater treatment facilities. **FAILURE TO ABIDE BY THESE LAWS CAN LEAD TO CIVIL AND EVEN CRIMINAL PROSECUTION.**

When dealing with sludge issues you may have to seek permits or approval from the federal Environmental Protection Agency as well as the New Mexico Environment Department's Ground Water Quality Bureau (NMED-GWQB), Surface Water Quality Bureau (NMED-SWQB), and Solid Waste Bureau (NMED-SWB). Although it is not

practical to outline all of the regulations surrounding each of the sludge use and disposal practices, the following is an overview of the practices most common to our state.

## **LAND APPLICATION OF BIOSOLIDS**

Land application of biosolids is a beneficial use practice that involves applying sludge to vegetated land at or near the vegetation's agronomic uptake rate. In addition to supplying the vegetation with nutrients, the condition of the soil is improved. Three major areas of concern exist with regard to sludge that is land applied. These are; (1) pathogenic contamination, which is generally measured with the indicator organism Fecal Coliform (2) vector attraction reduction (VAR) which prevents animals from being attracted to the sludge and (3) toxins or potential toxins such as heavy metals, PCBs and nitrogen compounds which could contaminate the natural environment.

The law that governs the disposal and use of wastewater sludge is Title 40 of the Code of Federal Regulations (CFR), part 503 (commonly referred to as the 503 sludge regulations). The 503 sludge regulations set forth treatment techniques that are to be employed to reduce the level of pathogens in sludge before it can be land applied. Two tiers of pathogen reduction through treatment exist: Class "A" and Class "B". Class "A" sludge is of high quality and can generally be sold or given away to the general public if it also meets the VAR and heavy metals requirements of part 503. Class "B" sludge is of lesser quality, but can still be land applied in bulk when specific management practices are followed and the sludge meets the VAR and heavy metal requirements of part 503. Approval or even a permit from NMED-GWQB may also be necessary to land apply Class "B" sludge.

One of the most common Class "A" treatment options is the composting process. Composting is a thermal aerobic biological process. Generally speaking, sludge is placed in a pile, called a windrow, along with wood chips or other mulched green waste. Bacteria and other organisms in the pile begin to digest the sludge and green waste. The pile is mechanically aerated or turned to provide oxygen so that the aerobic organisms remain active. The activity of the organisms creates substantial heat and high temperatures in the compost pile will result. To meet Class "A" standards, a temperature over 55° C (131° F) must be maintained for fifteen days with five complete pile turnings during that time. Careful control of the mixture and moisture content are required to achieve such high temperatures through aerobic organism activity alone. The high temperature and digestion greatly lower the number of pathogenic organisms remaining in the finished product. A special "Compost Facility Operator" license is required by the state for the operators of compost facilities in New



Mexico. These licenses are different from wastewater treatment facility operator's licenses.

### **SURFACE DISPOSAL OF SLUDGE**

If sludge cannot be beneficially used, it must be disposed of. Surface disposal is a common method of disposing of large amounts of sludge, both in liquid and solid forms. Surface disposal involves applying sludge to the land surface well above the agronomic uptake rate of any vegetation that may be present. The sludge can be injected as a liquid 1 –3 ft below the surface or spread on the land as a solid and then plowed in to incorporate it into the soil. The 503 sludge regulations have specific requirements for surface disposal operations. These requirements mainly involve the maximum amount of heavy metals and other toxins that can be applied to the land (for all time) as well as VAR options, site restrictions and management practices that must be followed. A permit is required from the NMED-GWQB for all sludge surface disposal sites and ground water monitoring will most likely be required as part of the permit. Although it is not generally considered as environmentally friendly of an option as land application, surface disposal can be a safe and economical alternative when performed properly.

### **LANDFILLING OF SLUDGE**

Landfilling sludge is one of the least desirable options for sludge disposal; however, it is a common practice in New Mexico. It is undesirable because valuable landfill space is wasted on material that could be incorporated back in to the soil as a benefit. Landfilling of sludge should only be practiced when economics or poor sludge quality make it practical. In order to landfill sludge, the NMED SWB requires that a sludge disposal plan be developed and that a hauler that is licensed to haul "special wastes" transport the sludge.

### ***References***

Office of Water Programs, California State University, Sacramento, *Operation of Wastewater Treatment Plants*, Volume II, 5<sup>th</sup> ed., Chapter 12  
Office of Water Programs, California State University, Sacramento, *Operation of Wastewater Treatment Plants*, Volume III, 2<sup>nd</sup> ed.,  
Title 40, Code of Federal Regulations part 503

## CHAPTER 12: TERTIARY TREATMENT

---

Tertiary treatment is the name given to processes designed to remove various pollutants from the wastewater stream other than the common BOD, and TSS. The two main subjects covered under tertiary treatment are Phosphorus removal and Nitrification and Denitrification. In addition Wetlands processes as a tertiary treatment process will also be covered here.

### CONSTRUCTED WETLANDS

Constructed wetlands are the name given to a process designed to provide small scale wastewater treatment. The focus of wetlands has been the need to remove nitrogen from the waste stream. Biologically, constructed wetlands operate much the same way as natural wetland processes.

### THEORY OF OPERATION

Constructed wetlands operate by using wetland plants to up take the nutrients in the wastewater. In theory they were expected to nitrify and denitrify wastewater using a combination of microbiological growth and aquatic plants. Typical plants include Bulrushes and Cattails.

Constructed wetlands come in many forms including Subsurface flow, and overland or ponds. The main difference between these two is whether the wastewater is allowed to surface and be acted on by the sun and wind.

In Subsurface flow (also known as reed beds) the wastewater is distributed via a system of pipes below the surface in a bed of gravel or pumice. This type of system operates much like a trickling filter in that a microbiological colony is established to remove the nutrients from the wastewater. These units' are often found in conjunction with septic tanks. The septic tanks were to remove settleable solids which would cause clogging of the media and force the water to the surface. Often found lacking in the design of the systems is an adequate method for removal of the large objects common to wastewater streams. Grit removal is also a problem, with the accumulation of grit causing a lack of detention time in the septic tanks. The unavoidable suspended solids from the septic tank along with the inability of the media to slough off solids (as a trickling filter does) has been found to plug the media and forces the wastewater to the surface anyway.

These beds are planted with bulrushes and cattails which, in addition to removing nutrients, are also supposed to provide oxygen to the subsurface area of the media preventing septic conditions and the associated odors.

In actual practice these systems have problems starting with the high oxygen demand placed on the bed by allowing the

water to turn septic in the septic tank. The high oxygen demand, in addition to the suspended solids leaving the septic tanks, force high oxygen demand water to the surface where odors have been found to develop. In a study done by W. Daniel Boivin, Evaluation of Constructed Wetlands Performance in New Mexico Mr. Boivin states subsurface flow constructed wetlands are incapable of removing the nitrogen in septic tank effluent to the New Mexico Water Quality Commission standards." Key to this is the need for additional oxygen to assist in the nitrification process.

One of the big selling points in the constructed wetlands systems is the lack of maintenance needed in the system. In actual operation this has not been the case. Maintenance is essential for these systems to operate at the minimal levels obtained in the field. The annual removal of the vegetative growth is needed to keep the systems healthy. This vegetative growth is the SLUDGE removed from the system. In addition, most of the systems have required mechanical aeration, which come with associated electrical and maintenance costs.

### OVERLAND FLOW WETLANDS

Constructed wetlands using surface flows are another type of constructed wetlands found in New Mexico. The surface application of wastewater prevents the plugging of the media noted in subsurface flows. In addition the environment more closely simulates the natural wetland environment found in nature. In this style of wetland treatment it is common for lagoon type systems to be incorporated into the design. The addition of a lagoon provides additional oxygen to the wastewater and provide for treatment through the conventional algae/wind action of the lagoons.

While this design addresses some of the problems with a subsurface flow the problem of odors remain. It stands to reason that a constructed swamp would produce the same type of swamp gasses that are produced in natural wetlands. In addition the wetlands design most often seen does not provide for the BOD loading of wastewater coming from a septic tank. In the overland flow design care must be taken to remove accumulated debris from the system. The addition of Gambusia (a mosquito eating fish) for mosquito control may also be warranted.

### EFFECTIVE USES OF CONSTRUCTED WETLANDS

The most successful wetland operation has been at the end of conventional treatment processes such as Activated Sludge, or Lagoons. In this manner the wetland operates as a polishing process. The filtering action provided by the media and plant growth has been shown to be a viable

option for the filtering of TSS and nonsoluble BOD in treated wastewater effluents. The problem with this is the filtering will also lead to clogging of the wetlands. Treatment for removal of nitrogen has not been as successful. Most data reported on wetlands has been sporadic and inconsistent. Long term testing of wetland effluents, by Michael Richard, Ph. D. on systems in Colorado, shows periodic purging of nitrogen and phosphorus by the wetland systems.

### **WETLANDS OPERATIONS AND MAINTENANCE**

While there is very little an operator can do to control or improve the operation of wetlands, there is maintenance required.

Much of the maintenance is similar to the maintenance of lagoon systems. The dikes need to be maintained. A low growing grass should be planted to prevent erosion. The grass should be cut regularly and the clippings disposed of. Burrowing animals will be attracted to the lush vegetation and need to be discouraged from burrowing into the ground around the wetlands.

Housekeeping is essential to keeping odors, insects and rodents under control. Screenings and grit removed in the pretreatment of the wastewater need to be removed daily and disposed of properly. Trash must not be allowed to accumulate on the grounds and an overall neat and clean appearance should be maintained.

The vegetation growing in the wetland will need to be removed at the end of the growing season. While burning these plants is an option, care needs to be taken to protect the lining of the wetlands as well as any exposed plastic pipe (sampling ports, distribution pipes) in the area. The exposed pipe can be covered with wet burlap and then enclosed by a 5 gallon bucket prior to setting the wetlands on fire. Permits for burning the wetlands also need to be obtained from the proper authorities. Insure that a good supply of water and manpower is available to prevent the fire from escaping the wetland area. The plants can also be cut and the cuttings will need to be removed and properly disposed of.

### **PROCESS CONTROL TESTING**

The wetland system needs to be tested. Testing should include pH, temperature, DO, and nitrate. Effluent DO, pH, and temperature testing should be done at least twice a week. Based on this testing, changes to the flow pattern should be made to maintain a minimum effluent DO of 0.5 mg/l. Nitrogen sampling should include both influent and effluent for total nitrogen as well as testing the effluent for nitrate nitrogen. Weekly or at least monthly testing for nitrogen should be considered. In order for this data to be

of use, good flow measurements along with a totalized flow will be necessary. The flow measurements need to be taken at the influent and effluent of the facility.

Records need to be kept. The records of flow and process control testing are necessary for the proper operation and maintenance of the system. In addition the operator needs a copy of the as-built drawings and all permit testing done on the facility. Daily records of the temperature and weather conditions will also be helpful in troubleshooting the system.

## **PHOSPHORUS REMOVAL**

### **PHOSPHORUS AS A NUTRIENT**

Phosphorus provides a nutrient or food source for algae. Phosphorus combined with inorganic nitrogen poses serious pollution threats to receiving waters because of high algae growths which result from the presence of the two nutrients in water. Algae in water are considered unsightly and can cause tastes and odors in drinking water supplies. Dead and decaying algae can cause serious oxygen depletion problems in receiving streams which in turn can kill fish and other aquatic wildlife.

By removing phosphorus in the effluent of a wastewater treatment plant, the lake or river that the treatment plant discharges into will have one less nutrient that is essential for algae growth. This reduction in an essential nutrient reduces the growth of the algae.

### **NEED FOR PHOSPHORUS REMOVAL**

The U.S. Environmental Protection agency and other water quality regulating agencies recognize the need to protect rivers and lakes from excessive growths of algae. Because of this, the agencies are requiring that wastewater treatment plants remove phosphorus in the effluent in order to protect the river or stream by eliminating a nutrient that can cause algae growth.

### **TYPES OF PHOSPHORUS REMOVAL SYSTEMS**

Lime precipitation, luxury uptake, and filtration following aluminum sulfate flocculation are the most common types of phosphorus removal systems.

### **LIME PRECIPITATION**

When lime (calcium hydroxide (Ca(OH)<sub>2</sub>) is mixed with effluent from a wastewater treatment plant in sufficient concentration to bring about high pH in the water, a chemical compound is formed which consists of phosphorus, calcium and the hydroxyl (OH<sup>-</sup>) ion. This compound can be flocculated or combined in such a way as to form heavier solids which can settle in a clarifier for phosphorus removal. A substantial amount of the lime

reacts with the alkalinity of the wastewater to form a calcium carbonate precipitate which also settles out with the phosphorus sludge.

**How the Lime Precipitation Process Removes Phosphorus**

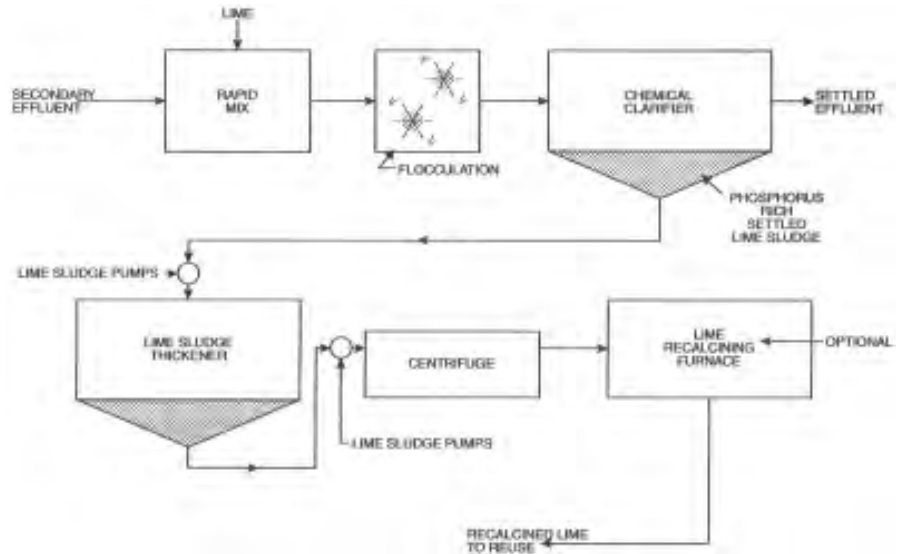
There are three general physical or chemical reactions which take place during lime precipitation for phosphorus removal.

1. Coagulation. When chemicals are added to wastewater, the result may be a reduction in the electromagnetic forces which tend to keep suspended particles apart. After chemical addition, the electrical charge on the particles is altered so that the suspended particles containing phosphorus, tend to come together rather than remain apart.
2. Flocculation. Flocculation occurs after coagulation and consists of the collection or agglomeration of the suspended material into larger particles. Gravity causes these larger particles to settle.
3. Sedimentation. As discussed in previous chapters on primary and secondary clarification methods, sedimentation is simply the settling of heavy suspended solid material in the wastewater due to gravity. The suspended solids which settle to the bottom of clarifiers can then be removed by pumping and other collection mechanisms.

**Equipment Necessary for Lime Precipitation**

Lime precipitation for phosphorus removal requires lime feeding systems, mixing and flocculation areas, chemical clarifiers for sedimentation and the proper pumps and piping for removal of lime phosphorus sludge. Other equipment includes facilities for pH adjustment of the effluent, recovery of the lime, and disposal of the phosphorus sludge.

For a more complete understanding of Lime Precipitation read the section on Phosphorus removal in the Operation of Wastewater Treatment Plants, Volume III, 2<sup>nd</sup> ed.

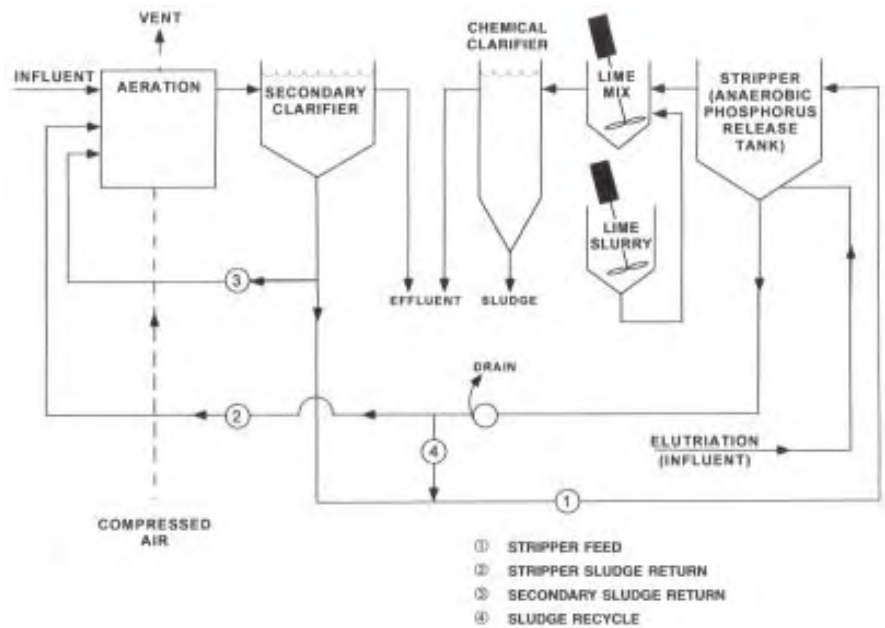


**Figure 12.1 - Lime Precipitation Process**

Reprinted, with permission, from *Operation of Wastewater Treatment Plants*, Vol. III, 2<sup>nd</sup> ed., Office of Water Programs, California State University, Sacramento Foundation

**LUXURY UPTAKE**

Luxury uptake of phosphorus is a biological treatment process whereby the bacteria usually found in the activated sludge treatment portion of the secondary wastewater treatment plant are withdrawn to an environment without oxygen (anaerobic). When the bacteria are faced with the situation of apparent death, the bacteria release phosphorus from their cell structure in large quantities. Phosphorus can then be removed and disposed of by using lime for settling similar to the previously discussed lime clarification



**Figure 12.2 - Luxury Uptake of Phosphorus (elevation flow diagram)**

Reprinted, with permission, from *Operation of Wastewater Treatment Plants*, Vol. III, 2<sup>nd</sup> ed., Office of Water Programs, California State University, Sacramento Foundation



process. After the bacteria have released their phosphorus, they are placed back into an ideal environment with oxygen and food. In this environment, since the bacteria are lacking in phosphorus in their cell structure, the first thing they take in is phosphorus. This phosphorus take-up is known as luxury uptake and is used in the process for biological removal of the phosphorus within the wastewater treatment facilities.

Bacteria found in normal activated sludge process use phosphorus within the make-up of the cell structure that forms the bacteria. When the bacteria are in a state of Endogenous respiration or are very hungry and need food and oxygen they tend to absorb phosphorus quite freely. This process is called luxury uptake in which the bacteria take excess phosphorus into their bodies due to the stimulation of being placed in a proper environment containing food and oxygen. When these same bacteria are placed in an environment where there is no oxygen (anaerobic), the first element that is released by the bacteria as they begin to die is phosphorus. As the phosphorus is released, it can be drawn off and removed from the wastewater stream.

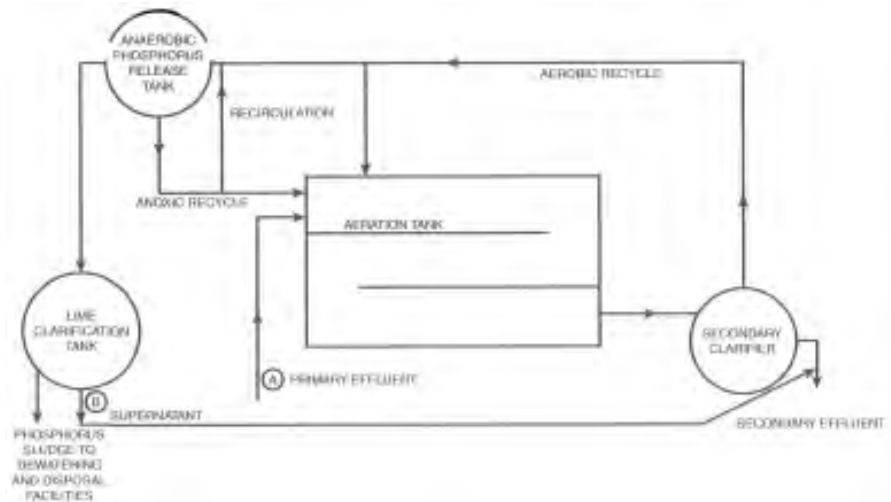
### Wastewater Treatment Units Used

Luxury uptake of phosphorus is found at activated sludge treatment plants. The units used include the standard ones for an activated sludge plant plus a relatively deep detention basin where anaerobic conditions exist.

Another unit commonly found in the luxury uptake and removal system is a lime clarification tank (clarifier) which is usually capable of treating 10 percent of the wastewater flow stream through the treatment facility. Return pumps and piping continue to move the activated sludge through an anaerobic state to a phosphorus release point and back to aeration for the luxury uptake process to begin all over.

### Basic Principles of Operation

Because luxury uptake can only take place in a very controlled environment, the bacteria cannot be exposed to any condition which would prevent them from either taking up phosphorus into their cell structure or releasing the phosphorus at the proper time. The basic operation requires the operators to remove the activated sludge from the secondary clarifier and provide the proper detention time in an anaerobic tank for the release of the phosphorus trapped within the cell structure of the bacteria. The operator must closely regulate the time of the anaerobic



**Figure 12.3 - Luxury Uptake of Phosphorus (plan flow diagram)**

Reprinted, with permission, from *Operation of Wastewater Treatment Plants*, Vol. III, 2<sup>nd</sup> ed., Office of Water Programs, California State University, Sacramento Foundation

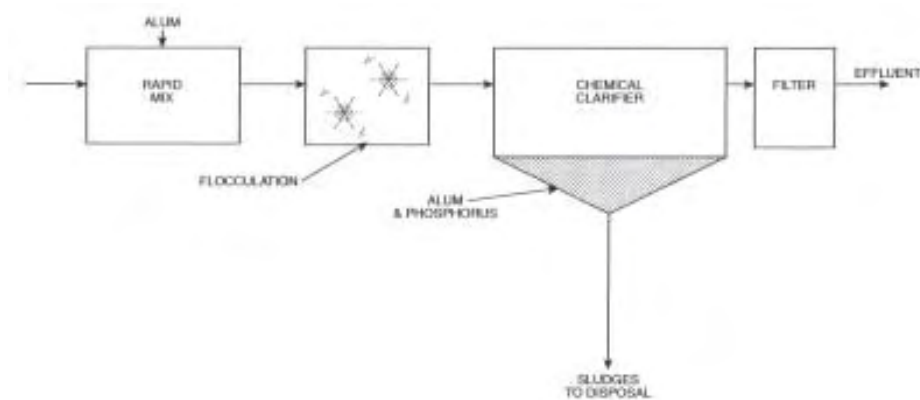
condition. The bacteria should not be allowed to die. However, the length of time should be sufficient to remove as much of the phosphorus as possible. Return the activated sludge to an area of the aeration tank where sufficient oxygen and primary effluent exist so that the bacteria can be revived and can take up the maximum amount of phosphorus within their cell structure.

### **ALUMINUM SULFATE FLOCCULATION AND PRECIPITATION (SEDIMENTATION)**

Aluminum sulfate (alum) in combination with wastewater also can flocculate phosphorus in much the same way as lime precipitation. The flocculation that happens with aluminum sulfate addition is the formation of aluminum phosphate particles that attach themselves to one another and become heavy and settle to the bottom of a clarifier. The aluminum sulfate and phosphorus mixture can then be withdrawn, thereby removing the phosphate or phosphorus from the wastewater flow. This alum floc is difficult to settle out in a clarifier. Therefore, a sand or mixed-media filter is usually placed after the clarifier to remove the remaining floc.

Aluminum sulfate (alum) can be used in the same manner as lime for precipitation of phosphorus in a clarifier. The same principles of coagulation, flocculation and sedimentation apply when using alum for the removal of phosphorus in effluent from a secondary treatment facility. However, because of the difference in cost between aluminum sulfate and lime, lime is more commonly used for the precipitation of phosphorus.

When alum is used for phosphorus removal, two general reactions occur. In the first reaction, alum reacts with the



**Figure 12.4 - Alum Flocculation as used in a Clarification Process**

Reprinted, with permission, from *Operation of Wastewater Treatment Plants*, Vol. III, 2<sup>nd</sup> ed., Office of Water Programs, California State University, Sacramento Foundation

alkalinity of the wastewater to form an aluminum hydroxide floc.

Phosphorus removal is by the formation of an insoluble complex precipitate and by adsorption on the aluminum hydroxide floc. Depending on the alkalinity of the wastewater, dosages of 200 to 400 mg/l of alum are commonly required to reduce phosphorus in the effluent down to 0 to 0.5 mg/l. Optimum phosphorus removal is usually achieved around a pH of 6.0. Alum feed is frequently controlled by automatic pH equipment which doses according to the pH set point (the more alum, the lower the pH). Jar tests can be used to determine the optimum pH set point and alum dosage rate.

If it is necessary to achieve low effluent phosphorus residuals (less than 1.0 mg/l) in the effluent, the chemical clarifier is usually followed by either a pressure filter or a multi-media gravity filter. Phosphorus sludge from the clarifier goes to dewatering and disposal facilities. At present, there are no economical methods available for alum recovery.

**References**

Office of Water Programs, California State University, Sacramento, *Operation of Wastewater Treatment Plants*, Volume III, 2<sup>nd</sup>ed.,

# CHAPTER 13: NITROGEN REMOVAL

## THE NITROGEN CYCLE

Nitrogen, element number seven on the periodic table, is an essential part of living matter and a relatively common element on our planet. 70% of the atmosphere that we breathe is nitrogen, and plants and animals alike require nitrogen as one of the building blocks of living tissue. Because of the many oxidation states that nitrogen can assume, it exists in many forms. Ammonia (NH<sub>3</sub>), nitrite (NO<sub>2</sub>), nitrate (NO<sub>3</sub>) and organically bound nitrogen are just a few of the many possible compounds of nitrogen. The nitrogen on our planet is constantly being changed from one form to another. These changes are illustrated by the nitrogen cycle.

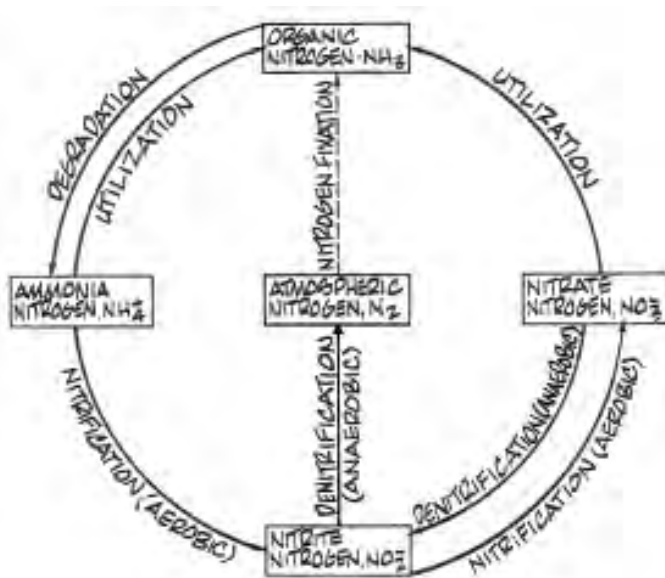


Figure 13.1 - Wastewater Nitrogen Cycle

## THE NEED FOR NITROGEN REMOVAL

Inorganic nitrogen provides a nutrient source for algae in receiving waters. The combination of nitrogen and phosphorous can cause uncontrolled algae blooms, which

choke waterways. As the lower layers of algae die off, the decomposing material can cause low D.O. conditions to exist. This condition is known as eutrophication. Algae can also cause taste and odor problems in drinking water supplies. Ammonia is toxic to many fish and aquatic species. When discharged from a treatment plant, it can cause fish kills and the death of other aquatic organisms in the receiving stream. Ammonia toxicity increases when little dilution is available in the receiving stream, and when the pH and temperature of the stream are elevated. Ammonia also creates a biological oxygen demand, which contributes to eutrophication in natural waters.

Nitrate can act as a nutrient in receiving streams and poses a health risk whenever it is allowed to contaminate drinking water supplies. The drinking water problem is of particular importance in New Mexico, where numerous septic tank discharges into shallow groundwater have resulted in the contamination of drinking water supply wells. When water that contains elevated levels of nitrate (> 20 mg/L) is consumed, an illness known as methemoglobinemia can occur. Typically affecting infants and the elderly, methemoglobinemia causes its victims to turn a pale blue/gray and become lethargic and ultimately comatose. Death can soon follow if no treatment is administered. It mostly affects infants, and so is commonly known as “blue-babies syndrome”.

For all of these reasons, the removal of nitrogen from wastewater continues to grow in importance. In the future, with increased effluent re-use and greater stress placed upon our rivers, lakes and streams, the importance of nitrogen removal will only increase.

## THE MANY FORMS OF NITROGEN

Nitrogen can combine with many other elements to form a variety of compounds. Table 13.1 summarizes the common forms of nitrogen of interest to the wastewater operator.

Table 13.1 - Common Forms of Nitrogen

Nitrogen Compound	Chemical Symbol	Location Where Commonly Found	Typical Concentration at This Location
Nitrogen Gas	N <sub>2</sub>	Atmosphere	70%
Ammonia/ Ammonium	NH <sub>3</sub> / NH <sub>4</sub>	Domestic Wastewater	30 – 50 mg/L
Total Kjeldahl Nitrogen (Sum of organically bound nitrogen and ammonia/ ammonium).	TKN	Domestic Wastewater, Effluent	30 – 60 mg/L
Nitrate	NO <sub>3</sub>	Nitrified Effluent	1 – 35 mg/L
Nitrite	NO <sub>2</sub>	Partially Nitrified Effluent	0.1 – 2 mg/L

As indicated in the table, nitrogen is present in domestic wastewater mainly in the form of ammonia and organically bound nitrogen. (Depending upon pH, ammonia can exist in solution as a gas, (NH<sub>3</sub>), or in solution as a dissolved solid; ammonium (NH<sub>4</sub>)). Ammonia and organic nitrogen compounds can be measured collectively using the Total Kjeldahl Nitrogen (TKN) test method.

Although they may do a good job at removing BOD, TSS and pathogens, modern wastewater treatment plants remove only a small amount of the TKN present in the influent, unless configured specifically for nitrogen removal. There are a variety of methods for removing nitrogen from wastewater. Table 13.2 lists the most common.

### BIOLOGICAL NUTRIENT REMOVAL

In the natural world, changes to nitrogen compounds are mostly accomplished biologically, by living organisms. These organisms live in environments that are aerobic, anaerobic and even anoxic. Modern wastewater treatment plants can be designed (or operated in a modified fashion) to manipulate microorganisms into changing nitrogen compounds. Typically, nitrogen is in the form of ammonia and organic nitrogen in influent. If accomplished in the correct order, the nitrogen compounds that enter the influent (mainly ammonia) can be converted first into nitrate and then converted into nitrogen gas (N<sub>2</sub>), which escapes into the atmosphere and is thus removed. This process is known as nitrification/denitrification. To understand how it works, it is important to understand how (and why) microorganisms change nitrogen from one compound to another. Each of the major processes is described below.

### NITROGEN FIXATION

The majority of nitrogen exists as nitrogen gas in the earth's atmosphere. Specialized plants, known as legumes, can capture atmospheric nitrogen and turn it into plant matter. This process is known as nitrogen fixation. Legumes accomplish nitrogen fixation through a symbiotic relationship with a group of aerobic, facultative and anaerobic bacteria that live near their roots. These bacteria are actually responsible for transforming atmospheric nitrogen into compounds that the plants can readily use, such as nitrate. The plant's use of nitrogen results in increased plant matter. As the plants are consumed by higher life forms, the organically bound nitrogen is passed along for use by other organisms.

### ANAEROBIC DECOMPOSITION

Organically bound nitrogen can be broken down into ammonia by anaerobic bacteria through the process of anaerobic decomposition. A good example of this is what happens in a septic tank. Much of the organic nitrogen

**TABLE 13.2 TYPES OF NITROGEN REMOVAL SYSTEMS**

System	Operational Considerations
<b>1. PHYSICAL TREATMENT METHODS</b> A. Sedimentation B. Gas Stripping	<b>1. Expensive</b>
<b>2. CHEMICAL TREATMENT METHODS</b> A. Breakpoint Chlorination B. Ion Exchange	<b>2. Expensive</b>
<b>3. BIOLOGICAL TREATMENT METHODS</b> A. Activated Sludge Processes B. Trickling Filter Processes C. Rotating Biological Contactor Processes D. Oxidation Pond Processes E. Land Treatment Processes (Overland Flow) F. Wetland Treatment Systems	<b>3. A-D</b> Operational control. Additional costs for oxygen to produce nitrification.  <b>3. E &amp; F</b> Land requirements. Suitable temperatures. Control of plants.

Reprinted, with permission, from *Operation of Wastewater Treatment Plants*, Vol. III, 2<sup>nd</sup> ed., Office of Water Programs, California State University, Sacramento Foundation

that enters a septic tank is converted into ammonia, which is released in the septic tank effluent. For this reason, the ammonia concentration coming out of a septic tank is often higher than the ammonia concentration going in. Organic acids are formed as by-products of anaerobic decomposition, which tend to lower the pH of wastewater passing through the process.

### NITRIFICATION

Nitrification is the process by which ammonia is oxidized into nitrite and then nitrate. Working under strict aerobic conditions (> 1.0 mg/L D.O.), two groups of autotrophic microorganisms accomplish nitrification. The species *Nitrosomonas* is primarily responsible for converting ammonia into nitrite, while the species *Nitrobacter* converts nitrite into nitrate. Both organisms are strict aerobes and are very sensitive to changes in their environment. Rapid changes to pH, temperature, D.O. levels and other factors can result in a large-scale die off. In this sense, the nitrifiers are the "prima donnas" of the wastewater microorganism world. The rate at which nitrification will occur in a wastewater treatment facility is regulated by the numbers of nitrifiers available.

Nitrification can be accomplished in activated sludge systems, trickling filters, RBCs, lagoons and other types



of treatment facilities, provided conditions are right. Because it is a strictly aerobic process, sufficient levels of dissolved oxygen must be provided. Typically, a D.O. level of at least 1 - 2 mg/L must be maintained to realize efficient nitrification. However, the D.O. that is available affects the nitrification rate. More D.O. will result in higher levels of nitrification, up to a maximum of about 4.0 mg/L of D.O. In order to completely nitrify each pound of ammonia, 4.6 pounds of dissolved oxygen are required.

The nitrifiers can only carry out efficient nitrification within a pH range of 7.5 – 8.5. Outside of this range, the rate of nitrification slows to generally unacceptable levels. Alkalinity is consumed during nitrification as part of the biological reaction. For each pound of ammonia nitrified into nitrate, 7.2 pounds of alkalinity (as CaCO<sub>3</sub>) are destroyed. Because of the destruction of alkalinity through the release of hydrogen ions, sustained nitrification causes a drop in pH. In communities that use treated surface water for their potable supply, which are often low in alkalinity, the insufficient alkalinity is sometimes responsible for limiting the rate of nitrification in the wastewater treatment facility. This problem is easy to overlook.

#### **DENITRIFICATION**

Denitrification is the process by which microorganisms reduce nitrate to nitrogen gas. A number of species that occur in wastewater are capable of accomplishing denitrification. These are sometimes referred to as *facultative organisms*. All of the organisms that can accomplish denitrification are Heterotrophic, because they can metabolize complex organic substances. Normally, Heterotrophic organism will metabolize waste using dissolved oxygen whenever it is available (> 0.1 mg/L). When placed in anoxic conditions, (an environment having < 0.1 mg/L dissolved oxygen), the facultative organisms can turn to the oxygen bound in nitrate as a means of metabolizing waste. Utilizing the oxygen contained within the nitrate molecule results in the release of nitrogen gas. Given time or agitation, the nitrogen gas will escape from solution and exit into the atmosphere. This phenomenon is commonly observed in secondary clarifiers, where the rising gas bubbles float particles of sludge to the surface.

Denitrification occurs in two steps. First, nitrate is reduced to nitrite. Next, nitrite is reduced by the microorganism dissimilation process to gaseous forms of nitrogen (primarily N<sub>2</sub>).

Denitrification can be accomplished using fixed growth reactors, such as trickling filters, RBCs and constructed wetlands system (although this use is somewhat uncommon in New Mexico). More commonly, denitrification is

accomplished in modified activated sludge systems that incorporate anoxic zones.

The rate at which denitrification can occur is limited by the presence of dissolved oxygen. If more than 0.1 mg/L of D.O. is present, the facultative organisms will use the D.O. for respiration, instead of turning to nitrate. For this reason, it is critical that dissolved oxygen be eliminated. This typically requires that a large source of carbon be provided for the microorganisms to metabolize. Influent is commonly fed into anoxic zones to provide a carbon source, however, in some cases, alternative sources of carbon must be used. Methanol has been successfully employed as a source of carbon to drive denitrification, although the complication and expense often outweigh the benefits.

Temperature has a profound effect upon denitrification. At liquid temperatures of 10° C (50° F), denitrification tapers off dramatically. In fact, 10° C can be considered a lower limitation for denitrification. Below this temperature, biological denitrification cannot be used to effectively remove nitrate. This fact causes many problems with wastewater treatment facilities in cold climates that must remove nitrogen for permit compliance. The impracticality of warming large amounts of wastewater for the purposes of achieving denitrification makes the 10° C temperature wall a very hard barrier to contend with.

#### **LAND APPLICATION OF EFFLUENT**

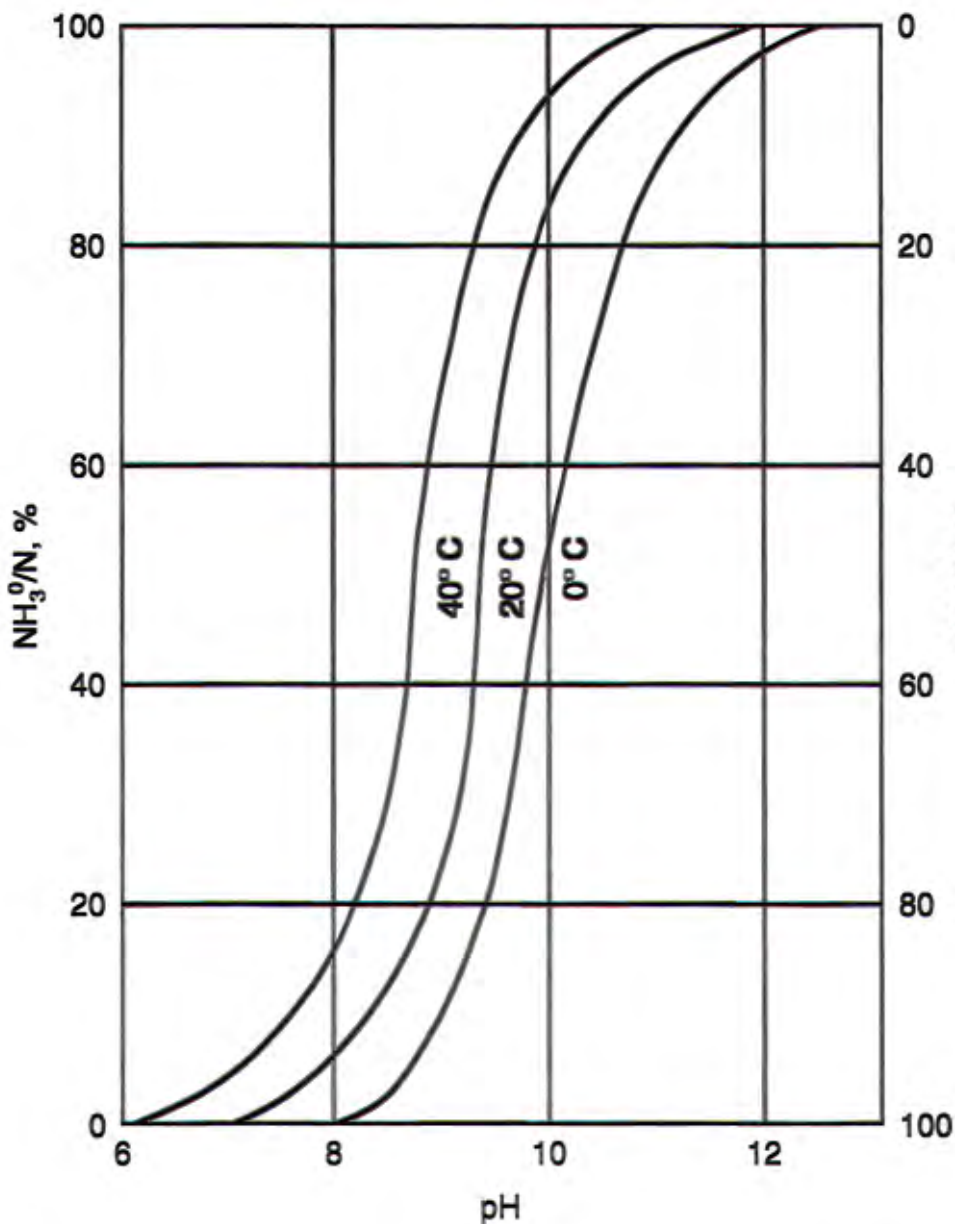
Many dischargers in New Mexico utilize land application of effluent as a means of removing residual nitrogen from treated effluent under permits issued by the NMED Ground Water Quality Bureau. In this method, nitrogen in the effluent is applied at the agronomic uptake rate of a crop that is grown with the effluent, such as turf, landscaping or feed crops. As the nitrogen is applied to the crops, the growing plants take it up as fertilizer. When the green plants are cut and removed, the nitrogen bound in them is removed, and thus prevented from contaminating the underlying ground water. The reporting requirements for this type of discharge are discussed in further detail in “Chapter 15, Sampling and Reporting”.

#### **PHYSICAL NITROGEN REMOVAL**

Nitrogen can be removed from wastewater through physical means. The most common method is ammonia stripping, which is described below.

#### **AMMONIA STRIPPING**

Ammonia (NH<sub>3</sub>) exists as a gas in solution. Ammonium (NH<sub>4</sub>) is a dissolved solid. Depending on the pH, nitrogen will exist as ammonia or ammonium.



**Figure 13.2 - Effects of pH and Temperature on Equilibrium Between Ammonium Ion ( $NH_4^+$ ) and Ammonia Gas ( $NH_3^0$ )**

Reprinted, with permission, from *Operation of Wastewater Treatment Plants*, Vol. III, 2<sup>nd</sup> ed., Office of Water Programs, California State University, Sacramento Foundation

Ammonia, because it is a gas, will come out of solution readily and exit into the atmosphere (strip). Ammonium, as a dissolved solid, will not. Therefore, to effectively strip ammonia from wastewater, the pH must be raised to a point that most of the compound will exist as ammonia. At pH 11 and a temperature of 25° C, the percentage of the compound that exists as ammonia is 98%. At this pH, agitation of the wastewater or spraying the wastewater into fine droplets will result in a high level of ammonia removal through stripping. Caustic ammonia stripping usually employs a packed tower with a counter current of forced air. High levels of ammonia removal can be reliably achieved, however the cost is generally prohibitive.

well. When the addition of more chlorine results in a comparable increase in the free residual, the breakpoint has been achieved.

Breakpoint chlorination requires relatively high volumes of chlorine compared with the amount of ammonia being oxidized. In fact, the chlorine to ammonia ratio is around 10:1. This means that it takes 10 pounds of chlorine to oxidize one pound of ammonia into nitrogen gas. The high demand makes breakpoint chlorination impractical for any use other than for polishing an effluent following another nitrogen removal process. In this practice, the bulk of the influent ammonia is removed through biological processes and then the remaining 1–2 mg/L of ammonia is removed through breakpoint chlorination.

To a lesser extent, this phenomenon is responsible for much of the nitrogen removal that is achieved by lagoon systems. Because the pH of lagoons is often elevated over 8.5 during periods of high algae activity, ammonia stripping can be responsible for removal of much of the nitrogen in the wastewater. Although this method offers an inexpensive and simple means for nitrogen removal using lagoons, please note that the effectiveness is limited and effluents with less than 10 mg/L total nitrogen are hard to obtain.

### CHEMICAL NITROGEN REMOVAL

There are two common chemical methods for removing nitrogen from wastewater; breakpoint chlorination and ion exchange. Neither is used on a widespread basis in New Mexico as a means of discharge permit compliance.

#### BREAKPOINT CHLORINATION

Ammonia/ ammonium nitrogen can be oxidized to nitrogen gas with chlorine. Breakpoint chlorination is the term used to describe the process. To reach the chlorine breakpoint, enough chlorine must be added to satisfy all of the demand in the wastewater. Any ammonia in the wastewater is oxidized to nitrogen gas, and all other pollutants are oxidized as

## ION EXCHANGE

The ion exchange process can be used to remove a variety of pollutants from wastewater, including ammonia. Ion exchange involves passing ammonia-laden wastewater through a column that contains natural or synthetic ion exchange resins. A naturally occurring resin (or zeolite) known as clinoptilolite is commonly used. The columns are generally 4 – 5 feet in depth packed with 20 X 50 mesh particles. As wastewater passes through the column, ammonium ions in the wastewater are absorbed by the clinoptilolite. When the absorptive capacity of the resin is used up, the column is regenerated through a caustic wash, which releases the absorbed ammonium from the resin by converting it into ammonia, which is then removed through gas stripping. Clinoptilolite resin can also be regenerated using brine solution. When the brine is passed through the column, the sodium in the brine replaces the absorbed ammonium at the exchange sites of the resin. The brine can then be discarded or the ammonium can be removed and the brine can be reused to regenerate the column.

Ion exchange is generally considered an expensive method of ammonia removal. However, it is also very effective when properly employed. Because of plugging of the ion exchange resin by bio-slimes, this method is generally only applied to high quality secondary effluents that have been filtered and disinfected.

## OPERATIONAL CONTROL OF NITRIFICATION/ DENITRIFICATION

The two part process of biological nitrogen removal through nitrification/denitrification requires that ammonia is first converted into nitrite and then nitrate, and then that the nitrate be converted into nitrogen gas, which is released to the atmosphere.

### NITRIFICATION

The nitrification portion of biological nitrogen removal can be accomplished using either fixed film or suspended growth reactors. In either case, a sufficient quantity of oxygen and ample time is required for the microorganisms to carry out the process. No matter which type of reactor is used, the process must be operated in such a way that ammonia is oxidized completely to nitrate. If the process results in the formation of only nitrite but not nitrate, disinfection problems will result where chlorine disinfection is employed. This is because nitrite exerts a high demand (2.5:1) as nitrite is oxidized to nitrate by chlorine.

Please note that a new approach to nitrogen removal is being employed that oxidizes ammonia to nitrite and then denitrifies the nitrite immediately without the creation of nitrate. This is accomplished biologically, all within the

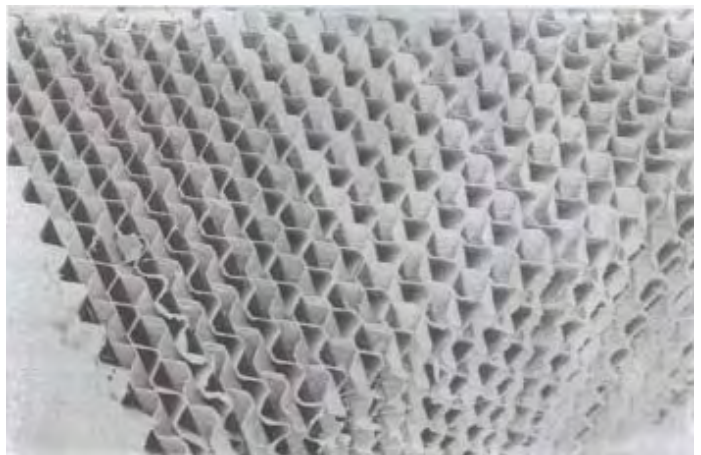
same aeration basin. The advantage to this new process is that significantly less oxygen is required. Control of the process can be difficult and requires on-line sensors and computer control of the aeration system.

## NITRIFICATION PROCESS MODES

### Fixed Film Processes

Nitrification in fixed film processes can be accomplished using a variety of treatment units. Fixed film processes have an advantage over suspended growth processes when it comes to nitrification, because the organisms responsible for nitrification prefer environments where they can attach to fixed surfaces. This allows nitrifiers to grow in stable colonies. Constructed wetlands, RBCs, fluidized beds, recirculating sand filters and trickling filters have all been used successfully for nitrification. Of these treatment units, trickling filters are most commonly employed and the following discussion is applicable mainly to the trickling filter process. However, many of the important points apply to all fixed film processes that are intended to nitrify.

Trickling filters (and all fixed film processes) provide BOD removal by converting soluble BOD into material that can be removed through solids separation (gravity settling or filtration). If nitrification is also a requirement, most of the BOD must be removed first. This is because the microorganisms responsible for nitrification cannot compete with the large numbers of Heterotrophic bacteria that form when a large BOD source is available for food. For this reason, dual stage trickling filters are often employed to provide BOD removal in the first stage and then nitrification in the second stage. BOD removal and nitrification can occur in the same trickling filter, with the BOD conversion occurring in the upper portion and nitrification in the lower portion of the filter media, but efficiency suffers.



**Figure 13.3 - Plastic Media Used for “Trickling Filter” Type Nitrification**

Reprinted, with permission, from *Operation of Wastewater Treatment Plants*, Vol. III, 2<sup>nd</sup> ed., Office of Water Programs, California State University, Sacramento Foundation



Very low organic loadings (< 25 lbs. BOD/day/1000cuft of media) are necessary to allow the growth of nitrifying bacteria in the same filter with large numbers of Heterotrophs. Recirculation through the trickling filter is critical to maintaining efficient nitrification. Because the nitrifiers are sensitive to changes in their environment, the filter media must be kept wet at all times and sufficient dissolved oxygen must be maintained. Recirculation provides for both requirements. Recirculation rates of 50 – 200% (and higher) have been used for nitrification. Occasionally, forced air ventilation will be used to improve the nitrification rate of trickling filters.

### **Suspended Growth Processes**

Activated sludge processes can be operated in a variety of modes. Not all modes of operation are conducive to nitrification. Conventional activated sludge lends itself well to nitrification because the plug flow through the basin allows for the assimilation of BOD by the Heterotrophs prior to the start of nitrification. Adequate detention times and dissolved oxygen levels must be maintained.

It is also of great importance to maintain a large enough population of nitrifiers in the system (higher SRT). This requires an increased solids inventory over that which is required for BOD removal alone. Extended aeration activated sludge has even greater advantage for nitrification due to long detention times and high sludge ages. Contact stabilization activated sludge generally does not provide for nitrification because of the high F:M that these systems operate at and the short detention times in the contact zone. Step feed activated sludge can be used for partial nitrification, however, because influent is introduced near the end of the aeration basin, ammonia can pass through without being fully oxidized to nitrate.

### **Nitrification Process Control**

When an adequate population of nitrifiers is present, and suitable conditions of dissolved oxygen, alkalinity and temperature are maintained, nitrification systems are relatively easy to operate. The control of nitrification in a fixed film reactor depends mainly upon: (1) the recirculation rate, and (2) the applied loading. The control of nitrification in suspended growth reactors depends upon: (1) the SRT or MCRT, and (2) the dissolved oxygen levels. Temperature affects nitrifiers as it affects all biological activity. Colder temperatures slow the process.

For activated sludge, the detention time in the aeration basin must be at least 4 hours and preferably >8 hours. The typical MLVSS concentration required to maintain an active population of nitrifiers is > 1500 mg/L. Dissolved oxygen levels of 2 – 4 mg/L are typical for conventional activated sludge nitrification processes, while extended aeration plants typically need only 1 – 1.5 mg/L of D.O.

Alkalinity is consumed during the nitrification process at a rate of 7.2 parts of alkalinity for each part of ammonia oxidized. Because of this, alkalinity determinations (along with D.O. readings) offer one of the best day-to-day operational controls for nitrification. A drop in the pH of wastewater may or may not accompany nitrification, depending upon the alkalinity available and pH at the start of the process. Any wastewater containing less than 50 mg/L of alkalinity is likely to experience a significant drop in pH during nitrification.

If the pH drops below 6.5, nitrification will effectively cease. For this reason, it is sometimes necessary to add alkalinity in order to maintain nitrification. If you suspect that low alkalinity is inhibiting nitrification, investigate carefully before taking action. Remember that 24-hour composite samples can often mask fluctuating alkalinity and pH drops. If the pH drops low enough to inhibit nitrification, alkalinity will have to be added to the influent. Lime, soda ash and sodium hydroxide are the most commonly used chemicals that are added to increase alkalinity in nitrifying systems.

The optimum wastewater temperature for nitrification ranges from 15° - 30° C (60° – 95° F). Nitrification is inhibited at low temperatures, and as much as five times the detention time may be necessary to accomplish complete nitrification in the winter as opposed to the summer. Because there is no way to control the wastewater temperatures, operators must adjust other process parameters to compensate for the lower growth rate of the nitrifiers during low temperatures. Typically, increasing the MLVSS concentration, increasing the MCRT, and increasing the pH slightly are the methods used to accomplish this. Under warm weather conditions, nitrification will proceed at a lower pH, lower MCRTs and with lower MLVSS concentrations.

The growth of nitrifying organisms is affected by the nitrogenous load applied to the system. In fact, the population of nitrifiers will be limited by the concentration of ammonia in the influent. Organic nitrogen, phosphorous and trace elements are essential for the growth of the microorganisms in any nitrifying system. The generally recommended BOD to nitrogen to phosphorous ratio is 100:5:1 for BOD reduction alone. In nitrifying systems, ratios containing significantly more nitrogen can be treated. If any of these constituents is not available in sufficient quantities, treatment will suffer.

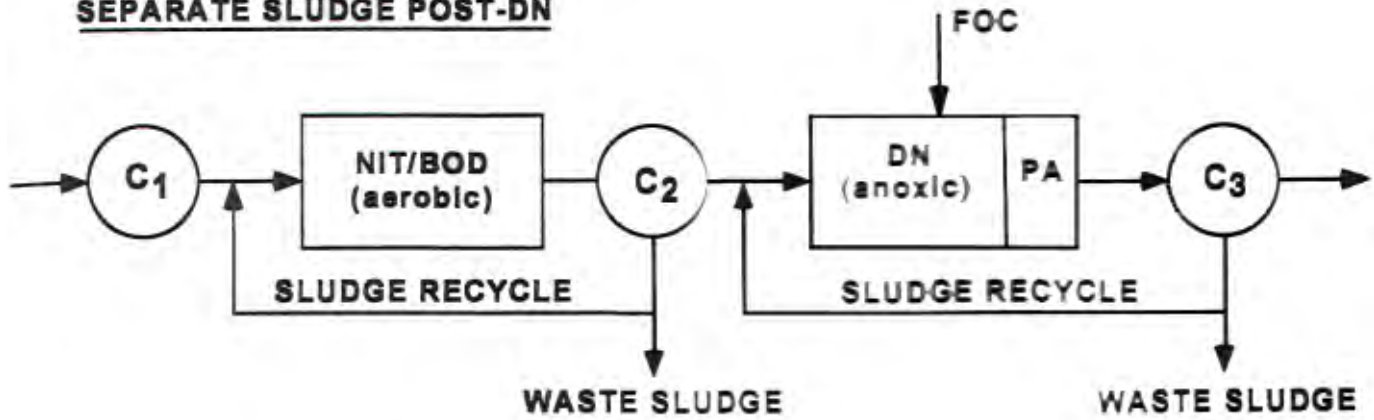
In some circumstances, it is only necessary to nitrify ammonia into nitrate. For example, for a treatment plant that discharges into a large river, ammonia toxicity may be a problem but nutrient loading may not. Under this



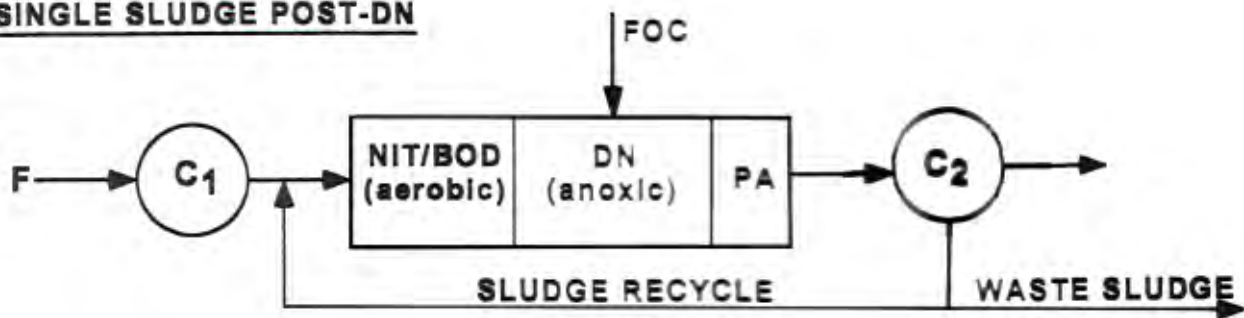
TABLE 13.3 NITRIFICATION TROUBLESHOOTING GUIDE  
 (Adapted from PERFORMANCE EVALUATION AND TROUBLESHOOTING AT MUNICIPAL WASTEWATER TREATMENT FACILITIES,  
 Office of Water Program Operations, U.S. EPA, Washington, DC.)

INDICATOR/OBSERVATION	PROBABLE CAUSE	CHECK OR MONITOR	SOLUTION
1. Decrease in nitrification unit pH with loss of nitrification.	1a. Need more alkalinity to offset nitrification acidic effects. 1b. Addition of acidic wastes to sewer system.	1a. Alkalinity in effluent from nitrification unit. 1b. Raw waste pH and alkalinity.	1a. If alkalinity is less than 10 mg/L, start addition of lime or sodium hydroxide to nitrification unit. 1b. Initiate source control.
2. Inability to completely nitrify.	2a. Oxygen concentrations are limiting nitrification. 2b. Cold temperatures are limiting nitrification. 2c. Increases in total daily influent nitrogen loads have occurred. 2d. Biological solids too low in nitrification unit.	2a. Minimum DO in nitrification unit should be 1 mg/L or more. 2b. Temperatures. 2c. Current influent nitrogen concentrations. 2d. MCRT should be greater than 10 days; in cold temperatures it may need to be greater than 15 days.	2a. Increase aeration supply or decrease organic (BOD) loading on nitrification unit. 2b. Decrease organic loading on nitrification unit or increase biological population in nitrification unit. (Increase MCRT.) 2c. Place added nitrification units in service or modify pretreatment to remove more nitrogen. 2d. (1) Decrease organic loading on nitrification unit and decrease wasting or loss of sludge from nitrification unit. (2) Add settled raw wastewater (primary effluent) to nitrification unit to generate biological solids.
3. In two-stage activated sludge system, SVI (see Chapter 7, Section 7.3) of nitrification sludge is very high (greater than 250).	2e. Peak hourly ammonium concentrations exceed available oxygen supply. 3. Nitrification is occurring in first stage.	2e. Ammonium concentrations. 3. Nitrate in first stage effluent.	2e. Install flow equalization system to minimize peak concentrations or increase oxygen supply. 3. Transfer sludge from first stage to second and maintain lower MCRT in first stage.
4. Loss of solids from final clarifier.	4. (See activated sludge and sedimentation/flotation chapters, OPERATION OF WASTEWATER TREATMENT PLANTS, Volumes I and II.)		
5. Loss of solids from trickling filter or RBC.	5. (See trickling filter and RBC chapters, OPERATION OF WASTEWATER TREATMENT PLANTS, Volume I.)		

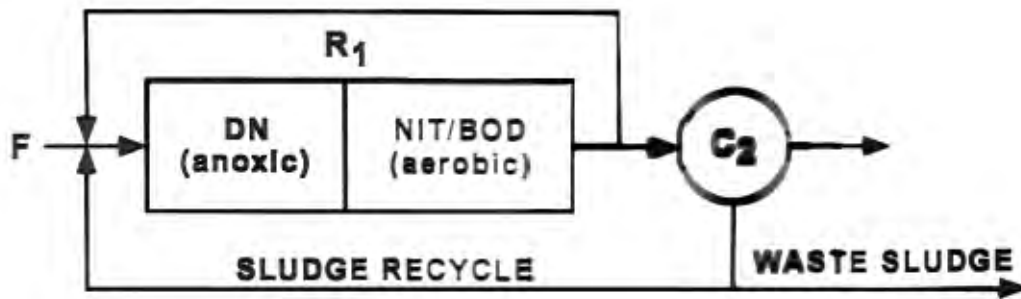
**SEPARATE SLUDGE POST-DN**



**SINGLE SLUDGE POST-DN**



**SINGLE SLUDGE PRE-DN**



**Legend**

- |                |                               |                |                |
|----------------|-------------------------------|----------------|----------------|
| C <sub>1</sub> | Clarifier 1 or Primary        | PA             | Post Aeration  |
| C <sub>2</sub> | Clarifier 2 or Secondary      | F              | Food Source    |
| C <sub>3</sub> | Clarifier 3                   | R <sub>1</sub> | Recirculation  |
| DN             | Denitrification               | OC             | Organic Carbon |
| NIT/BOD        | Nitrification and BOD Removal |                |                |

**Figure 13.4 - Nitrification and Denitrification Using Suspended Growth Reactors**

Reprinted, with permission, from *Operation of Wastewater Treatment Plants*, Vol. III, 2<sup>nd</sup> ed., Office of Water Programs, California State University, Sacramento Foundation

**TABLE 13.4 DENITRIFICATION TROUBLESHOOTING GUIDE**  
 (Adapted from **PERFORMANCE EVALUATION AND TROUBLESHOOTING AT MUNICIPAL WASTEWATER TREATMENT FACILITIES**,  
 Office of Water Program Operations, U.S. EPA, Washington, DC.)

INDICATOR/OBSERVATION	PROBABLE CAUSE	CHECK OR MONITOR	SOLUTION
1. Effluent COD shows sudden increase.	1. Excessive addition of methanol (or other oxygen-demanding material used).	1. Methanol dose.	1a. Reduce methanol addition. 1b. Install automated methanol feed system. 1c. Install aerated stabilization unit for removal of excess methanol.
2. Effluent nitrate shows sudden increase.	2a. Inadequate methanol addition. 2b. pH has drifted outside 7-7.5 range due to low pH in nitrification stage. 2c. Loss of solids from denitrifier due to failure of sludge return.	2a. Methanol feed system malfunction. 2b. Alkalinity. 2c. Denitrifier unit solids and clarifier unit.	2a. Correct malfunction. 2b. Correct pH with addition of lime or soda ash to raise pH to 7-7.5 range. 2c. Increase sludge return; decrease sludge wasting; transfer sludge from carbonaceous unit to denitrifier.
3. High head loss across packed bed or fluidized bed denitrification units.	2d. Excessive DO. 3a. Excessive solids accumulation in filter. 3b. Nitrogen gas accumulating in filter.	2d. Denitrifier DO should be as near zero as possible (less than 0.5 mg/L). 3a. Length of filter run—4-12 hours or more, this is the probable cause. 3b. Run times of less than 12 hours indicate this may be the cause.	2d. Reduce DO level. Turn some mixers off or reduce speed of blowers. 3a. Initiate full backwash cycle. 3b. Backwash bed for 1-2 minutes and return to service.
4. Packed bed or fluidized bed denitrifier that has been out of service blinds immediately upon start-up.	4. Solids have floated to top of bed and blind filter surface.	4. Solids on filter surface.	4. Backwash beds before removing them from service and immediately before starting them.



situation, the facility's discharge permit may limit the ammonia form of nitrogen in the discharge, but not limit nitrogen in other forms, such as nitrate. Simply converting the incoming ammonia into nitrate is sufficient to meet the permit limit for ammonia in this case. In many other situations, it is necessary to actually remove the nitrogen by finishing the nitrification/denitrification cycle.

## **DENITRIFICATION**

The microorganisms involved in denitrification are much more varied and plentiful than those involved in nitrification. They are also much less sensitive to environmental changes than the nitrifiers. Systems that nitrify and denitrify have the advantage of regaining about 50% of the alkalinity lost during nitrification, because alkalinity is created as part of the denitrification process. Biological denitrification can be accomplished with both fixed film and suspended growth processes. In New Mexico, denitrification is typically performed using anoxic zones as an adaptation of the activated sludge process, although constructed wetlands cells, lagoons and even septic tanks have all been used to provide the anoxic conditions necessary to induce denitrification.

## **DENITRIFICATION PROCESS MODES**

### **Fixed Film Processes**

The fluidized bed biological denitrification process works by passing wastewater through a bed of suitable media such as sand. As the wastewater moves through the bed, microorganisms attached to the media utilize the nitrate in the wastewater as a source of oxygen for metabolizing carbon compounds. Trickling filters and RBCs have been designed to provide for denitrification in a similar fashion, although these processes must be modified to exclude dissolved oxygen. As for all biological denitrification systems, a carbon food source must be supplied to promote metabolism by the denitrifying organisms. Primary effluent, methane gas, methanol or any other source of carbon can be used. In fixed film reactors, the carbon source can even be organic matter that is trapped in the reactor itself.

This use of a trapped carbon source for denitrification has been accomplished in constructed wetlands, although it is difficult to control and the success of the method is questionable. For all biological denitrification systems, dissolved oxygen must be excluded from the system; otherwise, the organisms will utilize any available D.O. rather than utilizing nitrate for cell metabolism. In general, fixed film systems are not as well suited to biological denitrification as suspended growth systems.

### **Suspended Growth Processes**

Activated sludge can be modified quite easily to provide for biological denitrification. By creating an anoxic environment, where the mixed liquor and influent are kept in suspension, but not aerated, controlled denitrification can be achieved. There are many ways of achieving anoxic conditions in activated sludge systems. Perhaps one of the easiest is to simply shut off the aeration system for several hours to allow anoxic conditions to develop. If carefully timed, this method can denitrify the entire contents of an aeration basin. This approach has been applied successfully to package plants that need to denitrify for permit compliance.

Another approach to creating an anoxic environment is taken in the sequential batch reactor (SBR) process. SBRs operate much as activated sludge, with the exception that the entire treatment process, including clarification, takes place within a single reactor basin. While an SBR is aerating, mixing and filling with influent, the organisms in the reactor are assimilating BOD and nitrifying ammonia into nitrate.

Next, the aeration is turned off, but the mixing and filling with influent continues. During this phase, the microorganisms in the reactor continue to assimilate BOD. In doing so, they quickly utilize the available D.O. (the basin becomes anoxic). Once the D.O. is exhausted, the facultative organisms turn to the oxygen bound up in nitrate as a source of oxygen that can be utilized and allow them to continue to metabolize BOD. SBRs often cycle between these two phases (aerobic and anoxic) several times before finally shutting off aeration and mixing so that the mixed liquor can settle and the clarified effluent can be decanted off and discharged. If the phases are carefully controlled, high levels of nitrogen and BOD removal can be achieved.

Recent development has led to activated sludge plants that have special, dedicated anoxic zones, which provide for denitrification. Anoxic zones have been utilized at the beginning, in the middle and at the end of aeration basins. Some zones are simply a portion of the basin that is mixed but not aerated (common in oxidation ditches), while others are isolated areas, separated by walls or baffles. In either case, the intent is to provide an area where the mixed liquor and a carbon source (normally influent) can come together for a set detention time. While in the anoxic zone, the organisms are forced to turn to the oxygen bound up in nitrate as a source of oxygen to be used while metabolizing the BOD contained in the carbon source feed.

Often, mixed liquor is recycled through the anoxic zone in order to denitrify the nitrate contained within it. This form of mixed liquor recycle is also used to maintain the desired



detention time within the anoxic zone, which is typically around 1 – 2 hours. Excessive detention times in the anoxic zone can overstress the non-facultative organisms (like the nitrifying bacteria), and so must be avoided or the nitrification side of the process will suffer.

When anoxic zones are located at the beginning of an aeration basin, another benefit is realized. In an anoxic zone located at the head of an aeration basin, the facultative organisms rapidly take up the easy to assimilate organic matter (soluble BOD) contained in the influent. This reaction results from the stress caused by the anoxic conditions. This rapid uptake of the easy to assimilate organic matter robs many filamentous type bacteria of their main food source; soluble BOD. As a result, an anoxic zone operating in this fashion will actually *select* against the growth of many types of filamentous organisms. For this reason, anoxic zones situated at the front of an aeration basin are often referred to as anoxic selectors, or bio-selectors. Selectors of this type offer the most powerful long-term tool for combating filamentous organisms available to operators.

It is important to understand that the effect does not work on all types of filamentous organisms. Much to the regret of many an operator, the filamentous organism *Microthrix Parvicella* does not respond to the selector effect. In addition, other filaments are only slightly selected against or are not affected at all.

### **DENITRIFICATION PROCESS CONTROL**

The control of any biological denitrification process centers around three things: (1) excluding dissolved oxygen, (2) maintaining the proper detention time, and (3) ensuring an adequate carbon source to drive the organisms to denitrify.

A D.O. meter is one of the most useful tools for troubleshooting denitrification systems. If any D.O. (>0.1 mg/L) is allowed to exist in the anoxic zone, denitrification will be hampered. Checking for the presence of dissolved oxygen with an accurately calibrated D.O. meter is one of the most fundamental process control checks.

The detention time in the anoxic zone should be around 1 – 2 hours in order to ensure adequate denitrification. Detention times lower than 1 hour usually do not allow enough time for the complete utilization of any residual D.O. and for complete denitrification. Detention times that are excessive will overstress or even kill the strict aerobes in the system. The most sensitive obligate aerobes are the nitrifying bacteria. If they are killed off due to excessively long anoxic exposure, the entire nitrogen removal process will fail. Mixed liquor recycling is used to maintain the desired detention times for separate sludge systems and pre-denitrification systems.

Figure 13.4 shows the typical configurations for separate sludge post-denitrification, single sludge post-denitrification and for single sludge pre-denitrification. Of these configurations, single sludge pre-denitrification is the most common in New Mexico. Furthermore, single sludge pre-denitrification has the additional advantage of exerting the selector effect against susceptible filamentous bacteria.

For SBRs, the denitrification detention time is a function of the length of the anoxic phase, which can be adjusted by the operator. It is often necessary to increase the length of the anoxic phase of an SBR during the winter months, when cold temperatures make oxygen easier to dissolve and slow the metabolism of the microbes. Conversely, the length of the anoxic phase can often be shortened during warm weather.

Ensuring an adequate source of carbon is generally not a problem, because the influent contains all of the carbon that is needed to drive the denitrification process. However, for some configurations (particularly separate sludge post-denitrification), it may be necessary to add a additional carbon source. In the past, methanol was used for this purpose, however, the cost and complication of methanol injection almost always make the use of influent as a carbon source much more desirable.

### **References**

Office of Water Programs, California State University, Sacramento, *Operation of Wastewater Treatment Plants*, Volume III, 2<sup>nd</sup> ed., chapter 21

# CHAPTER 14 : WASTEWATER LABORATORY

---

## PURPOSE OF THIS CHAPTER

Performing accurate laboratory analysis of wastewater samples is a skill that takes time and practice to master. While advanced degrees and higher education are not required, critical thinking and trouble shooting abilities are a must. This chapter is intended to *introduce* the reader to laboratory tests, equipment and procedures. It is *not* intended to provide a comprehensive explanation of how to perform the tests.

## IMPORTANCE OF THE LABORATORY

Laboratory tests are critical for the efficient control of the wastewater treatment plant as well as for the effluent monitoring required by discharge permits. Having a laboratory at your disposal is one of the most valuable assets a wastewater operator can have. Good operators turn to the laboratory for much of the information they need to troubleshoot problems in the treatment process. In fact, laboratory data can often be used to prevent problems from developing in the first place. Most medium and large plants in New Mexico have a full time lab analyst and the necessary laboratory equipment to run most NPDES and NMED-GWQB monitoring test as well as most process control tests. Small systems typically have only a limited ability to run process control test and take all of their effluent monitoring samples to a contract laboratory (with the exception of pH and total residual chlorine, which must be analyzed immediately).

## LABORATORY CERTIFICATION

Many states require that lab analysts be certified, but New Mexico is not one of them. Laboratories and lab personnel that conduct monitoring test for NPDES and NMED-GWQB permits in New Mexico do not have to meet any certification requirements, however, laboratories that conduct drinking water analysis do. Lab experience does count toward operator certification, but it is awarded at one-quarter time. (Four years as a wastewater lab analyst counts as one year toward wastewater operator certification testing requirements). Many lab analysts are also certified operators.

## LABORATORY SAFETY

Many of the activities performed in wastewater treatment systems are dangerous, and working in the laboratory is no exception. Lab workers handle dangerous chemicals such as acid, bases and volatile compounds as well as infectious wastewater samples. Because of the hazards, it is important that lab workers consistently wear personal protective equipment (PPE) whenever appropriate. The PPE that is required for common daily tasks in the laboratory include; safety glasses, a face shield, goggles, rubber gloves and a

lab coat. Laboratories themselves must be equipped with a variety of safety equipment. This equipment may include; a fume hood, an emergency shower and eyewash, fire extinguishers, a first aid kit and hazardous materials storage cabinets. Access to the laboratory should be limited (doors always closed during working hours and locked after hours).

## BASIC LABORATORY EQUIPMENT AND PROCEDURES

Wastewater laboratories are filled with specialized instruments that must be used in a precise manner in order to obtain the desired accuracies. Understanding what level of accuracy is required is the first step in choosing what piece of equipment to use. Knowing which equipment delivers the desired level of accuracy is the second. Mastering the proper procedures and techniques associated with each instrument is also very important. The following is an overview of the basic lab procedures that all lab analysts should understand.

## WEIGHTS AND MEASURES

In the wastewater laboratory, the ability to precisely weigh items is very important. When a very high degree of accuracy is called for ( $\pm 0.1$  mg), an *analytical balance* is used for weighing items. Other types of scales, such as a pan balance or a triple beam balance are used when less accuracy is needed. Whatever type of scale is used, it should be in good working order and checked for accuracy regularly. For analytical balances, this means verifying the accuracy against National Institute of Standards and Technology (NIST) certified Class 1 weights on a regular basis (generally monthly). It is also good laboratory practice to have balances checked and calibrated by an instrument service technician once a year.

## GLASSWARE

The glassware used in wastewater laboratories is constructed from specialized borosilicate glass. There are several types of glassware. Each type has a variety of uses based on the level of accuracy required. To properly read the volume of liquid in glassware, the level is measured to the bottom of the meniscus. (See Figure 14.1.)

Glassware should always be kept scrupulously clean and is easiest to clean immediately after use. Thorough cleaning with non-phosphate soap and scrubbing followed by several rinses with de-ionized water is the preferred method. The main types of glassware are as follows:

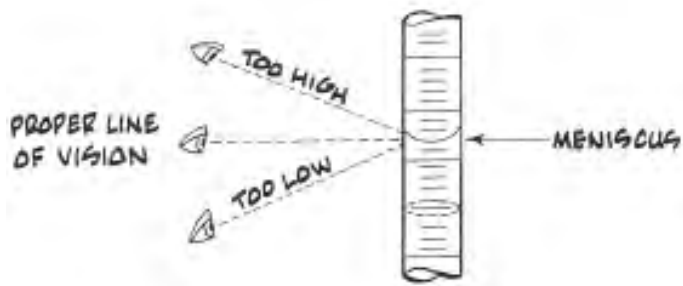


Figure 14.1 - How to Read the Meniscus

- Mohr pipets are graduated, but not calibrated to the tip. If allowed to drain completely, too much liquid will be delivered. Because of this, Mohr pipets are never “blown out”.
- Serological pipets are graduated, so they can deliver different measured volumes. Serological pipets must be “blown out” to deliver the measured volume and are designated with a frosted band or double lines near the top.

### Beakers & Flasks

- Made of Borosilicate glass or plastic and used for mixing, heating, settling and other general procedures.
- Beakers and flasks are not used when accurate measurements of volume are required.

### Graduated Cylinders

- Made of glass or plastic and used where good accuracy is required.
- Glass graduated cylinders are calibrated “To Deliver” (TD) or “To Contain” (TC). TD cylinders deliver the stated volume, TC cylinders are used for creating specific dilutions.
- Plastic are calibrated TC *and* TD, because the drops left behind when the contents are poured from the cylinder are accounted for.
- Use a size close to the volume being measured.
- Use Class “B” tolerance or better.

### Volumetric Glassware

- Made of high-grade borosilicate glass and used where the *highest* level of accuracy is required, always labeled TC.
- Used to make up primary standards.
- Should be designated Class “A” tolerance.

### Pipettes

- Pipettes are used to accurately measure and transfer small amounts of liquids.
- There are two main types of pipets; transfer (volumetric; Class “A”), and measuring (Mohr or serological; Class “B”).
- The accuracy of a pipet is related to its type and the analyst’s technique.
- Pipets are classified by their operation:
  - Volumetric pipets will deliver the specified or desired volume when drained and “tipped” to the edge of the receiving vessel. This type of pipet should not be “blown out”.

### Burets

- Burets are used for volumetric titrations where high accuracy is required.
- They are made of borosilicate glass with a glass or Teflon stopper.
- When used properly, burets can deliver Class “A” tolerance.
- Digital titrators are now commonly used in-place of burets.

### TEMPERATURE MEASUREMENTS

Accurate temperature measurements are critical to many of the tests that are performed in the wastewater laboratory. Temperature measurements should be made with good mercury thermometers or digital thermometers. Never rely upon the temperature display built into an incubator or drying oven for an accurate indication of the instrument’s temperature. Thermometers located in BOD incubators and drying ovens should be placed in stoppered beakers that contain clean sand, water or mineral oil to protect the thermometer from breakage and mitigate rapid fluctuations in temperature that occur when the unit is opened. For water bath incubators, thermometers should be held upright with their mercury bulb submerged in the water bath itself. The temperature of all operating instruments should be recorded twice a day in an instrument temperature log. Use thermometers that have the sensitivity required for each test. For most tests, use a thermometer with graduations of 0.1° C. To verify the accuracy of laboratory thermometers, each thermometer should be calibrated against a NIST *certified thermometer* in its working range at least once per year. Once calibrated, laboratory thermometers should be flagged with the date of their last calibration and any correction factor. When a laboratory thermometer is read, the correction factor is included when the temperature is recorded to ensure that the most accurate temperature possible is maintained in the instrument.

### SOLUTIONS AND STANDARDS

Solutions consist of a liquid which has a solid dissolved or dispersed throughout it. The liquid medium is known as the *solvent* and the solid is known as the *solute*. The

concentration of a solution is expressed in terms of how many milligrams of solids are contained per liter of liquid (mg/L). A standard solution is a solution for which the concentration is known. Standards are often made up so that 1mL = 1 mg/L. Lab analysts can easily dilute standard solutions to a lower strength, such as when preparing a calibration curve.

There are two main types of standards: primary standards and secondary standards. A primary standard is a standard that is prepared by dissolving a weighed amount of a substance of a known composition in a measured final volume. A secondary standard is a standard for which the concentration is derived by comparison, such as by titration. For the highest level of accuracy, the solids used to make up a primary standard should be weighed using an analytical balance and the liquid volumes should be measured using Class "A" volumetric glassware.

Sometimes it is convenient to purchase and use solutions that have a specific concentration, which is based on the molecular weight of the solute. These are known as Molar Solutions (M). A molar solution consists of one gram (molecular weight) of a compound made up to one liter with distilled water. For example, the molecular weight of CaSO<sub>4</sub> is 136. If you create a solution that contains 136 grams of CaSO<sub>4</sub> made up to 1 liter, you will have a 1M CaSO<sub>4</sub> solution.

Another solution that is sometimes convenient is the Normal Solution (N). A normal solution contains one gram-equivalent weight of reagent per liter. An equivalent weight of a substance is defined as that weight which releases or accepts 1 mole of electrons. It takes equivalent volumes of acidic 1N solutions to neutralize equivalent volumes of caustic 1N solutions. (Caution, never directly mix strong acids and bases). Most laboratories maintain 0.05N, 0.1N and 1.0N working solutions of the most commonly used acids and bases.

The solutions used in the lab on an everyday basis are known as Stock Solutions. Stock solutions are made stronger than those used in various lab tests because stronger solutions are generally more stable than weak solutions. Stock solutions are easily diluted to give a desired working concentration. Stock solutions are considered standards when the concentration is very accurately known.

## OVERVIEW OF INDIVIDUAL TESTS

### BIOCHEMICAL OXYGEN DEMAND (BOD<sub>5</sub>)

Being able to measure the "strength" of wastewater is important for controlling treatment systems and for

measuring the effectiveness of treatment. The Biochemical Oxygen Demand (BOD) is a test that measures the biological and chemical oxygen demand of wastewater. In the BOD test, wastewater samples are incubated at 20° C for five days. During the incubation, microorganisms metabolize nutrients in the sample. In doing so, they use oxygen. If a lot of nutrients are present, the organisms will reproduce actively, creating a larger population and thus, using a lot of oxygen. Furthermore, chemical substances in the wastewater sample (such as hydrogen sulfide or sulfur dioxide) will react with oxygen, which also causes an oxygen demand. Because both types of oxygen demand are measured, the test is called the Biochemical Oxygen Demand.

### BOD Sample Collection and Preservation

Samples for BOD analysis may degrade significantly during storage between collection and analysis, resulting in low BOD values. For this reason, analyze samples promptly or cool samples to 4° C for storage. Warm stored samples to 20°C before analysis. For grab samples, analysis should be performed within two hours or the sample should be cooled to 4° C at time of sample collection. Standard Methods states that every effort should be made to begin analysis within 6 hours, but under no circumstances start analysis of grab samples more than 24 hours after sample collection. For composite samples, keep sample aliquots at 4° C during compositing and limit the compositing period to 24 hours. Use the same holding time criteria as for grab samples, starting the measurement of holding time from the end of the compositing period. Under the BOD methodology detailed in the Federal Register under the Code of Federal Regulations, (40 CFR 136), a maximum sample holding time of 48 hours following the last composite sample aliquot is allowable. However, be aware that this longer holding time should only be used out of clear necessity and that 40 CFR 136 should be cited as the sampling protocol. For all BOD samples, state the storage time, temperature and conditions as part of the result.

### Setting up the BOD

The BOD test is conducted in special 300 mL glass bottles, known as "BOD bottles". To begin setting up the test, a measured volume of sample is added to a BOD bottle. The amount of sample that is used depends upon how strong the lab analyst suspects the wastewater to be. For example, if the sample is raw influent, the analyst may only use a small portion, say 20 mL, whereas if the sample is very clear effluent, the analyst may use 250 mL. If the sample was disinfected, (effluent), there may not be enough live microorganisms in it to conduct the test, and so extra microorganisms must be added. These extra microorganisms are known as "seed". Usually, 1 – 3 mL of settled influent is used as a seed, which is added to the



BOD bottles containing sample. After the addition of seed, the BOD bottles are filled up the rest of the way with buffered dilution water that contains all of the things (other than food) that the microorganisms need to reproduce. Using a dissolved oxygen meter equipped with a special stirring probe, the dissolved oxygen in the BOD bottles containing sample, seed and buffered dilution water is then measured. This beginning dissolved oxygen level is known as the *initial D.O.*

### Incubating the BOD samples

After the initial D.O. has been measured in each of the BOD bottles, the bottles are sealed so that no oxygen can get in or out. Then, the BOD bottles are placed in an incubator that is specially designed for the BOD test. The samples are incubated at 20° +/- 1° C for 5 days. It is critical that the incubation temperature stay as close to 20° C as possible if the test is to be accurate. When samples are placed into the incubator in the morning, they should be read in the morning 5 days later. When placed into the incubator in the afternoon, they should be read 5 days later, in the afternoon. If the incubator allows the temperature to exceed 21 °C or go below 19 °C, all samples in the incubator become invalidated and cannot be used for reporting purposes.

### Reading the BOD

After the 5 days of incubation, the BOD bottles are removed from the incubator and the level of dissolved oxygen is again measured in the bottles. This is known as the *Final D.O.* The amount of dissolved oxygen that was consumed during the incubation is related to the strength of the sample and the volume of sample added to the bottle. Because the lab analyst knows the sample volume, a simple calculation can be performed to determine the concentration of BOD in milligrams per liter. (See Figure 14.2)

### Seed Corrections

As discussed earlier, when we are testing samples that have been disinfected (like effluent), there are not enough microorganisms alive in the sample to allow the test to run. Therefore, we add “seed” microorganisms to these types of samples in order to ensure there are live bugs to use the dissolved oxygen during the incubation time. Good seeding material is usually obtained by settling raw influent for at least 1 hour but less than 36 hours and then pipeting from 1 cm below the surface of the settled liquid.

Primary effluent, non-disinfected

secondary effluent and commercially prepared seed can also be used.

Unfortunately, no matter what the origin of the seed, some oxygen-demanding material (BOD) will be carried along with the seed microorganisms. In order to obtain the true BOD of the sample, we must subtract out the amount of organic material that came along with the seed microorganisms. To do this, we determine how many mg/L of D.O. are used per mL of seed by running seed controls along side the regular samples. (see Figure 14.3)

Knowing the BOD of the each seed control allows us to calculate the seed correction factor, which is the average of the seed controls multiplied by the mLs of seed added to each of the sample bottles. (See Figure 14.4.)

Ideally, the Seed Correction Factor should be between 0.6 and 1.0 mg/L. If it is too high, too much seed has been used in the sample bottles. If it is too low, more seed should be used in the sample bottles next time. Often, lab analysts have to adjust the amount of seed (and even the source of the seed) in order to stay within this range.

### Calculating BOD

To calculate the BOD for a seeded sample, we use the same equation shown above, except that we eliminate the oxygen demand caused by the seed by subtracting out the seed correction factor.

It is important to note that not all samples require seeding. Influent samples typically have a multitude of live microorganisms and therefore do not require seeding. If a lab analyst does not know if a sample has been disinfected or not, it is safest to seed the samples to ensure good test results. (See Figure 14.5)

$$\text{BOD, mg/L} = \frac{(\text{Initial D.O.} - \text{Final D.O.}) \times 300}{(\text{Volume of Sample used (mL)})}$$

Figure 14.2 - Concentration of BOD

$$\text{Seed Control} = \frac{(\text{Initial D.O. Seed} - \text{Final D.O. Seed})}{\text{mL of seed added to seed control bottle}}$$

Figure 14.3 - Seed Control

$$\text{Seed Correction Factor} = \text{average of seed controls} \times \text{mL of seed added to each sample bottle}$$

Figure 14.4 - Seed Correction Factor

$$\text{BOD, mg/L} = \frac{(\text{Initial D.O.} - \text{Final D.O.} - \text{Seed Correction Factor}) \times 300}{\text{Volume of sample used (mL.)}}$$

**Figure 14.5 - Calculating BOD for Seeded Samples**

### BOD Quality Control

Because this test relies in part upon living microorganisms, many things can go wrong, with the outcome being inaccurate results. To avoid this, quality controls are used when running the BOD. These are:

- Dilution water blanks
- Oxygen Depletion Rules
- Sample pH adjustments
- Dechlorination of Chlorinated Samples
- Dissolved Oxygen Meter Calibration
- Careful control of the incubator temperature
- Routine analysis of a standard (a stabilized sugar called Glucose/Glutamic acid is used)
- Annual analysis of an externally supplied standard

### Dilution Water Blanks

If the water that is used to make up the buffered dilution water contains organic matter or chemicals that will cause an oxygen demand, the test results will be incorrect. To ensure against this problem, two BOD bottles that contain only buffered dilution water are incubated along with the sample bottles and the seed correction bottles. These two bottles are known as “dilution water blanks”. If the difference between the initial D.O. and the final D.O. of the dilution water blanks is >0.2 mg/L, it indicates that something is wrong with the water used to make the dilution water, that the D.O. meter calibration is off, or that the glassware used in the test is contaminated. Whatever the cause, the analyst should work to correct the problem. When over-depletion of the dilution water blanks occurs, it should be highlighted on the benchsheet. If this data is used for permit reporting purposes, a notation should be made on the discharge monitoring report detailing the over-depletion problem. However, excessive oxygen demand in the dilution water blanks is not a reason to invalidate (throw out) the data from a BOD test.

### Oxygen Depletion Rules

Because the BOD test is essentially based on oxygen depletion, we must insure that enough oxygen is in the bottles at the beginning of the test and that enough oxygen remains in the bottle at the end of the test for us to accurately measure. The oxygen depletion rules outline the various aspects of oxygen levels that are acceptable during the test.

The depletion rules are as follows:

1. At least 2.0 mg/L of dissolved oxygen must be consumed in sample bottles during incubation or the results from that bottle are not included in calculating the BOD.
2. At least 1.0 mg/L of dissolved oxygen must remain in sample bottles following incubation or the results are not included in calculating the BOD.

If no bottles containing sample meet these depletion rules, the results can still be used for reporting purposes, but the data is suspect and the results should be recorded in such a way that the problem is indicated. If the data is used for permit reporting purposes (NPDES or NM Ground Water DPs), a notation should be made on the discharge monitoring reports that explains the problem.

### Sample pH adjustments

If a sample contains caustic alkalinity or acidity (defined as a pH or > 8.5 or < 6.0 respectively), the sample pH must be adjusted to near neutral. If samples have a pH of > 8.5 or < 6.0, they should be adjusted to a pH of between 6.5 and 7.5 before the analysis.

### Dechlorination of Chlorinated Samples

We have already discussed the need to seed samples that have been disinfected. However, if samples were disinfected with chlorine, any residual chlorine remaining in the sample could kill our seed microorganisms. **THIS WILL RESULT IN A BOD MEASUREMENT THAT IS MUCH LOWER THAN THE ACTUAL BOD.** In order to avoid this problem, all chlorinated samples must be checked for residual chlorine and dechlorinated with a freshly prepared 0.025 N sodium sulfite solution if any residual chlorine is found. After dechlorination, samples must be checked again to verify that no residual chlorine remains.

### Dissolved Oxygen Meter Calibration

The D.O. measurements conducted as part of the BOD test can be made in two ways; (1) chemically, through the Winkler titration, or (2) electrometrically, with a polarographic D.O. meter. Because of the difficulties involved with the Winkler titration method, almost all laboratories in New Mexico use D.O. meters for performing the BOD test.

D.O. meters can be temperamental devices. To be accurate, D.O. meters must be calibrated before each use, preferably close to the time that they will be used to make measurements. Calibration is typically done using the theoretical dissolved oxygen value of saturated air, after

correcting for variations caused by temperature and atmospheric pressure.

To obtain the accuracy required for the BOD test, an atmospheric pressure reading from an accurate (calibrated) barometer should be used to obtain the theoretical dissolved oxygen calibration value. This is different from the “altitude correction factor” which is acceptable when calibrating field D.O. meters, but the high degree of accuracy required demands it. Be aware that laboratory barometers should be calibrated against a local airport barometric reading, but the airport reading must be converted to a true barometric pressure that has not been adjusted for altitude.

### **Incubator Temperature Control**

BOD incubators look like refrigerators, but they actually can heat or cool as needed to maintain an inside temperature of 20° C +/- 1° C. Good laboratory practices dictate that the incubator temperature should be carefully determined and recorded at least two times a day for the entire incubation period. The thermometer used to measure the BOD incubator temperature must be calibrated against a thermometer certified by NIST at least once a year. If the temperature inside the incubator goes above 21° C or below 19° C at any time during the incubation period, the test is invalidated and the results cannot be used for reporting purposes.

### **Glucose Glutamic Acid Standard (GGA)**

Microorganisms metabolized Glucose (a simple sugar) very rapidly and at an unpredictable rate. Glucose that has been stabilized by the addition of Glutamic acid is metabolized by microorganisms at a steady rate. Because of this, GGA can be used as a BOD standard. [Remember, a standard is a substance whose chemical constituents are very accurately known]. Carefully weighing 150 mg of dry Glucose and 150 mg of dry Glutamic acid with an analytical balance and making it up to exactly one liter with pure water will yield a BOD standard.

A 2% dilution of this standard (6 mL in a BOD bottle) will result in a BOD of 198 mg/L. If the BOD of the standard is close to 198 mg/L, we assume that the measurements of the samples were accurate as well. The tolerance for the GGA standard is 198 mg/L +/- 30.5 mg/L.

In order to ensure that BOD tests are providing reliable results, a GGA standard must be run at least 10% of the time along with samples. If the GGA standard does not fall within the tolerances, the entire set of BOD sample data associated with the failed GGA standard becomes invalid (the sample data is thrown out and cannot be used for reporting). If one GGA bottle is within the tolerance and one is out, the data can still be used.

Because of the consequences of failing the GGA standard, most laboratories run GGAs with every sample set that is analyzed. This way, if the GGA fails, only that sample set is invalidated, as opposed to invalidating several weeks of data (if the GGA is run infrequently).

### **Externally Supplied Standard**

Even with all of the previously discussed quality control measures, the BOD test typically has an accuracy of +/- 15%. Because of this, it is important that externally supplied standards be analyzed at least annually to ensure that the level of accuracy being delivered is acceptable. Externally supplied BOD standards can be purchased commercially.

### **BOD benchsheet**

The following benchsheet shows how a BOD test looks on paper. Using the information on the benchsheet, try to calculate the BOD of this effluent sample. Remember to exclude data that does not meet the depletion rules and correct for the seed that was added to the sample bottles. Calculate the GGA standard to make sure that the test met quality control requirements. (See Figure 14.6)

### **FECAL COLIFORM MEMBRANE FILTER PROCEDURE**

The Membrane Filter Procedure for determining the density of Fecal Coliform bacteria is commonly used to monitor the effectiveness of the disinfection process of wastewater treatment plants in New Mexico. The procedure involves filtering known volumes of effluent samples through a membrane with a nominal pore size of 0.45 microns. The membrane containing the trapped Fecal Coliform microorganisms is then placed onto a growth medium (M-FC medium), sealed in a Petri dish and incubated for 24 hours. Any Fecal Coliform bacteria trapped on the membrane will grow into characteristic blue colonies that can be counted, yielding how many colony-forming units (CFUs) were contained in a 100 mL sample portion.

### **Fecal Coliform Sample Collection and Transport**

Fecal Coliform samples must be collected and transported in specially prepared bottles that have been sterilized and contain a small amount of dechlorinating chemical (Sodium Thiosulfate). If the sample has been disinfected with chlorine and does not get completely dechlorinated, the chlorine will continue to disinfect the sample in the bottle on the way to the lab, yielding a false low result. During preparation, Sodium Thiosulfate is added to Fecal Coliform sample bottles as a dechlorinating agent, and then they are sterilized in an autoclave.

Care must be taken to draw the sample aliquot into the bottle without washing out the dechlorinating agent. Only grab samples are taken, and they should be drawn directly from



Figure 14.6 - Biochemical Oxygen Demand Worksheet

Sampler Joe T. Operator  
 Name of Facility New Mexico WWTF  
 Date of Sampling 3/6/04  
 Time(s) of Sampling 10:00, 11:00, 12:00, 1:00, 2:00, 3:00  
 Exact Sampling Location Effluent V-notch weir  
 Type of Sample: Grab  Composite  Hour 6 hour  
 Flow at sample time:(GPM) 749, 695, 854, 347, 550, 465, 391

Sample Preservation: Refrigerated at 4°C  
 Date of Analysis: 3/6/04  
 Method Used: Method 5210, Standard Methods for the Examination of Water and Wastewater, 18th ed.

Note: If sample must be stored over 2 hours, refrigerate to 4°C. Sample temperature should be 20°C before analysis. Warm stored samples to 20°C in water bath.

**SAMPLE PRETREATMENT**

Sample pH: 7.2  
 Sample pH adjusted to: N/A  
 Seed Source: Settled Influent  
 Seed Collection: Date 3/6/04 Time 8:31 am

Sample Chlorinated? Yes; Cl<sub>2</sub> present 0.1 mg/L  
 Date of sodium sulfite prep.: 3/6/04  
 Volume of sodium sulfite used/liter sample: 0.3 mg/L  
 Sample rechecked for Cl<sub>2</sub>: <0.099 mg/l

**UNSEEDED DILUTION WATER BLANKS**

Bottle #	1	2
D.O. Initial (mg/L)	7.2	7.2
D.O. Final (mg/L)	7.1	7.2
Difference		

Note: Should be <0.2 mg/L after 5 days of incubation.

D.O. Meter calibration value 7.4 initial

D.O. Meter calibration value 7.3 final

**SEED CORRECTION**

Bottle #	3	4	5
mL Seed Used	3	6	9
D.O. Initial (mg/L)	7.1	7.1	7.1
D.O. Final (mg/L)	5.9	4.6	3.6
Difference			
D.O. Used/mL Seed			
Seed Correction Factor =			

Note: The Seed Correction Factor is the average of the D.O. used/mL of seed in the seed control bottles multiplied by the mL of seed used to seed the GGA and sample bottles.

**GLUCOSE-GLUTAMIC ACID STANDARD SAMPLE DATA**

Bottle #	6	7
ml Standard	6	6
ml Seed Used	2	2
D.O. Initial (mg/L)	6.9	6.8
D.O. Final (mg/L)	2.2	2.2
Difference		
Seed Correction Factor		
Corrected Difference		
BOD mg/L		

Note: GGA should be 198 ± 30.5 mg/L

Analyst (preparer): JTO

Analyst (reading): JTO

Bottle #	8	9	10	11
ml Sample	30	50	75	100
ml Seed Used	2	2	2	2
D.O. Initial (mg/L)	6.9	6.9	6.8	6.7
D.O. Final (mg/L)	4.3	3.0	1.7	0.4
Difference				
Seed Correction				
Corrected Difference				
BOD mg/L				
Average BOD (mg/L) =	(Should be) 17.9 mg/L			

Date & Time of initial reading: 3:35 pm, 3/6/04

Date & Time of final reading: 2:45 pm, 3/11/04

- Dilutions that result in a residual D.O. of at least 1 mg/L and a D.O. uptake of a least 2 mg/L after 5 days of incubation produce the most reliable results.
- Before use, seed should settle for at least 1 hr. and no longer than 36 hours at 20°C.

Note: Calculate data in shaded blocks



the flow stream, (not collected with a sample dipper and then poured into the bottle).

Sterile sample bottles should only be opened once, at the time of sampling. The lid of the sample bottle should never be allowed to become contaminated. Samples that will take longer than 1 hour to analyze should be cooled to between 1° – 4° C on ice or in a refrigerator and then transported in a cooler on ice to the laboratory. The maximum holding time for Fecal Coliform samples that will be used for state or federal permit reporting purposes is 6 hours.

### Setting up the Fecal Coliform Membrane Procedure

All materials used for the Fecal Coliform Membrane Procedure must be sterilized prior to running the test. Most labs purchase pre-sterilized Petri dishes, membranes, absorbent media pads and M-FC media. The equipment used to filter the samples is typically sterilized using an autoclave or ultra-violet light-sterilizing box. At the start of the test, the lab analyst disinfects the counter top where the test will be run using alcohol. Petri dishes are laid out for each sample volume to be filtered and absorbent pads are placed in the Petri dishes. Next, M-FC media is poured onto the absorbent pad. Any excessive M-FC media on the absorbent pad is then discarded by pouring it out into a sink or trash can.

### Filtering Samples

Using a set of tweezers that has been flame sterilized, a sterile membrane filter is placed upon a special filter funnel apparatus. Using a vacuum pump, a measured portion of sample is drawn through the membrane. A variety of sample volumes, ranging from dilutions that contain < 0.0001 mL of sample all the way up to 100 mL of sample, may be filtered through successive membranes. The sample volume range that is used is dependent upon the expected Fecal Coliform concentration.

Ideally, sample volumes or dilutions that yield between 20 and 60 colonies per plate should be selected. After the samples have filtered through the membrane, three successive 20 – 30 mL volumes of buffered dilution water are used to rinse the sides of the filter vessel and then drawn through the membrane filter. Next, the membrane is removed (using flame sterilized tweezers) and is carefully placed upon the absorbent pad containing M-FC media in

the Petri dish. The Petri dish is then sealed. This procedure is repeated for all sample volumes to be filtered.

### Incubating Samples

When all of the sample volumes have been filtered and placed into Petri dishes, they are collectively sealed in sterile, waterproof plastic bags and placed into a water bath incubator. Fecal Coliform samples are incubated at a very specific temperature: 44.5° C, +/- 0.2° C. Water bath incubators are generally used for this test because they can hold the temperature much more accurately than air incubators. After 24 hours of incubation, the Petri dishes are removed and the blue Fecal Coliform colonies are counted.

### Determining Fecal Coliform Densities

The number of Fecal Coliform in an effluent sample is reflected by how many colonies grew on the membrane during incubation and how much sample was filtered through the membrane. After incubation, remove the samples and count all of the blue colonies on each filter.

$$\text{Fecal Coliform CFUs/ 100 mL} = \frac{(\text{Number of Colonies Counted on Filter}) \times (100)}{\text{Volume of Sample Filtered, (mL)}}$$

**Figure 14.7 - Fecal Coliform Densities**

Samples should ideally have at least 1 plate with 20 – 60 colonies; however, samples are not rejected if there is a countable number. (See Figure 14.7.)

It is important to understand that the volume of sample filtered could be very small or up to 100 mL because the volume has to be adjusted for the expected Fecal Coliform concentration. For samples that are suspected to contain very high numbers of Fecal Coliform, a dilution is made that may contain only 0.1, 0.01, 0.001 mL/100mL of actual sample. Sometimes, it is necessary that dilutions are taken even further. For most wastewater treatment plant effluents, undiluted sample volumes of 10, 50 and 100 mL will commonly be filtered. If the sample is diluted, the actual volume of sample in the dilution (not the total volume, including dilution water) must be entered into the equation in order to obtain the correct CFU/100 mL density.

### Fecal Coliform Reporting

Fecal Coliform densities are reported using specific rules:

- Filters having 20 – 60 colonies growing on them are preferred. (Report only the results from plates with 20 – 60 colonies when they occur).
- If no plate has between 20 – 60 colonies, all the counts are added from the sample plates and divided by the total volume of sample filtered.

- Samples with growth covering the entire plate with no distinct colonies are reported as confluent growth.
- Samples with more than 200 colonies are reported as too numerous to count (TNTC).
- Confluent growth and TNTC plates cannot be used for DMR reporting purposes (re-sampling is required).
- If no sample plates have blue colonies and all Quality Control checks out, report result as < 1 CFU /100 mL.
- For DMR purposes - < 1 CFU /100 mL = 1

### Quality Control

Because the M-FC test is based on cultivating small numbers of microorganisms, many variables exist that can affect the accuracy of the test. The quality control procedures for the M-FC test attempt to eliminate sources of error.

The following quality controls are required at a minimum:

- **Positive control**  
Anything that is toxic in the materials used in the test will suppress their growth, giving false negative results. By testing the materials on a sample known to contain Fecal Coliform, the materials can be shown to perform as intended. Typically, either a diluted pure strain of *E. coli* or 1 – 2 mL of raw influent is used as a positive control. These sources should create the characteristic blue colonies filtered and incubated.
- **Sterility checks**  
Any contamination from sources containing Fecal Coliform bacteria will give false positive results. Sterility checks verify that the materials used in the test are not contaminated with bacteria. Tryptic Soy Broth (TSB) is used as a media to demonstrate sterile conditions. If Petri dishes, membrane filters, absorbent pads and other materials used in the test are incubated with TSB but show no growth, the material are sterile. If growth occurs, the materials are contaminated and should not be used in the test.
- **Negative control**  
In order to determine which bacteria are Fecal Coliform and which bacteria are not, the media that the bacteria are grown upon (broth) contains a chemical that is only taken up by Fecal Coliform, turning them blue. A negative control proves that the media will differentiate between Fecal Coliform and all other bacteria. Usually, an organism such as *Enterobacter Aerogenes* is used as a negative control. Colonies of *Enterobacter*

*Aerogenes* will grow on the membrane, but will be some color other than blue, usually tan.

- **Pre-blank**  
A pre-blank is used to demonstrate that the filter funnel apparatus was properly sterilized before the test. Pre-blanks are just like samples, except that 100 mL of sterile buffered dilution water are filtered. Pre-blanks are filtered BEFORE any of the samples. No growth should ever be observed on the pre-blank. If growth occurs, the filter funnel sterilizing procedures should be improved.
- **After-blank**  
An after-blank is used to demonstrate that the rinsing following filtering of the samples was adequate. After-blanks are just like pre-blanks, except that they are done AFTER the samples have been filtered. No growth should occur on the after-blanks. If growth occurs, sample carry over is occurring and the rinsing procedure following each sample filtration should be improved.

A positive control, negative control and sterility check are required for each new lot of materials to be used in the test. Pre-blanks and after-blanks should be run once for every 5 sample volumes filtered. Additionally, duplicate analysis must be conducted at least 10% of the time, (and more often if following good lab practices). If any problems with the positive control, negative control, sterility check, pre-blank or after-blank are observed, the data generated with the associated materials and procedures is suspect and should not be used for reporting purposes. If the incubator temperature ever falls below 44.3° C or exceeds 44.7° C, the sample data must be rejected. Rejected data must never be used for reporting purposes.

### Fecal Coliform Benchsheet

Figure 14.8 shows what the Fecal Coliform test looks like on paper. Using the information provided on the benchsheet, try to calculate the correct number of Fecal Coliform CFUs/100 mL.

### TOTAL SUSPENDED SOLIDS PROCEDURE

Solids in wastewater can be classified as Total Solids (TS), Total Suspended Solids (TSS) and Total Dissolved Solids (TDS). TS represent all of the solids in a wastewater sample, after the water has been evaporated off. TDS represent all of the solids in a wastewater sample that has passed through a 2-micron (or smaller) filter, after the water has been evaporated off. TSS represent all of the solids in a wastewater sample that remain trapped on a 2-micron (or smaller) filter, which has had all water evaporated off. From the perspective of process control of wastewater treatment plants and NPDES permit monitoring, TSS is the parameter of most importance. The TSS procedure

Figure 14.8 - Fecal Coliform Membrane Filter Method Benchsheet

Name of Facility: New Mexico WWTF Time of Analysis: 1:35 PM  
 Time of Sampling: 10:03 AM Date of Analysis: 3/6/04  
 Date of Sampling: 3/6/04 Analyst: Joe T. Operator  
 Exact Sampling Location: Effluent V-notch weir Method Used: Method 9222D, Standard Methods  
 Sample Preservation: Refrigerated at 4° for the Examination of Water and Wastewater,  
 Signature of Sampler: Joe T. Operator 18th edition

Quality Control	Membrane Filter	m-FC Broth	Adsorbent Pads	Waterbath 44.5° ± 0.2°	
Date of Purchase	2/06/04	2/23/04	2/06/04	Time In: 1:40 PM	Date In: 3/6/04
Lot number	8113912	908315	3453	Temp In: 44.4°	
Date of Expiration	4/01/05	11/11/05	4/01/05	Time Out: 1:30 PM	Date Out: 3/7/04
pH		7.4		Temp Out: 44.5°	

Filter funnel sterilized: <u>UV light, 2 min.</u>	Work area disinfected: <u>Yes, alcohol</u>
---	--

Dish	Sample Volume (mL)	Colonies on Membrane	CFU/100 mL	Plates Used in Count
Pre-blank	0	0	0	
1	10	3	30	
2	30	17	57	
3	50	37	74	
4	70	48	69	
5	100	74	74	
After-blank	0	0	0	

Sample Result: (Should be) 72 CFU/100 mL

Key:

	calculate data in shaded blocks
--	---------------------------------



involves filtering known volumes of wastewater through pre-weighed glass fiber filters and then drying the filters at 103° – 105° C in a drying oven. The residue trapped on the filter is then weighed to determine the TSS concentration in mg/L.

### **Total Suspended Solids Sample Collection and Preservation**

Samples to be analyzed for Total Suspended Solids content should be collected in clean polypropylene or glass bottles (typically 500 – 1000 mL). It is important that the material in suspension does not adhere to the container walls. Analyze samples as soon as possible because of the impracticality of preserving samples. Refrigerate samples at 4° C up to the time of analysis to minimize microbiological decomposition of solids. Preferably, do not hold samples more than 24 hours, but in no case hold samples more than 7 days. Bring samples to room temperature before analysis, because changes in the sample temperature/density will affect volumetric measurements.

### **Preparation of Glass Fiber Filters**

The filters used in the TSS test are specialized glass fiber filters with a nominal pour size of < 2 microns. Various companies supply these filters. These are a few examples: Whatman grade 934AH, Gelman type A/E, Millipore type AP40 and E-D Scientific Specialties grade 161. Other products that are demonstrated to give comparable results are allowable.

To prepare filters for use, insert the filter disk with the wrinkled (rough) side up in a filtration apparatus. Never handle the filter or aluminum dish by hand. Oil from your skin could cause an inaccurate test result. Always handle filters and aluminum dishes with forceps. Apply a vacuum and wash the filter with three successive 20 mL portions of reagent-grade water. Continue suction to remove all traces of water. Remove the filter from the filter apparatus and place it into an aluminum dish (known as a planchet). Dry filter and dish in an oven at 103 – 105° C for at least one hour.

If the filter will be used in the Volatile Suspended Solids test, ignite at 500 +/- 50° C for 15 minutes in a muffle furnace. Cool filter and dish in a desiccator and then weigh filter and dish on an analytical balance. Repeat cycle of drying and desiccating until a constant weight is obtained or until the weight change is less than 4% of the previous weighing or 0.5 mg, whichever is less.

The cleaning and complete drying of the filters is critical to obtaining accurate results with the TSS test. Rinsing the filters removes any loose debris from the filter. Verifying that the filters are completely dry before being

used in the test prevents the introduction of error attributable to wet filters. It is important that good records be maintained that demonstrate that the filter rinsing and drying was carried out correctly.

Most laboratories prepare a week or even a months worth of filters at a time. Store prepared filters in a desiccator until needed for analysis.

### **Selection of Volume to be Filtered**

The volume of sample to be filtered depends upon the amount of suspended matter in the sample. In general, only about 50 – 100 mL of raw influent can be filtered; while filtering 1000 mL of clean effluent is common. High solids content samples like mixed liquor from an activated sludge plant may only allow filtration of 10 – 20 mL. Samples should be carefully measured in clean graduated cylinders or using clean wide-tipped pipets. Choose sample volumes that yield between 10 and 200 mg dried residue. If more than 10 minutes are required to complete filtration, use less sample volume or use a larger diameter filter. When very low suspended solids wastewater is encountered, less than 10 mg of dried residue is acceptable, but compensate by using a high-sensitivity analytical balance (capable of measuring 0.002 mg) if very high accuracy is required.

### **Sample Filtration**

To begin sample filtration, assemble the filtration apparatus, place a filter with the wrinkled side up on the apparatus and begin suction. Wet the filter with a small amount of rinse water to seat it. While stirring the sample with a magnetic stirrer or after thoroughly mixing the sample in the sample container, transfer a measured volume to the filter funnel with a pipet or graduated cylinder. After the sample has been drawn through the filter, rinse the pipet or graduated cylinder and the walls of the filter funnel down with three successive volumes of about 10 mLs of rinse water, allowing complete drainage between washings. Some samples require more thorough rinsing. Continue suction until all liquid is removed from the filter. Carefully remove the filter and residue with forceps and transfer to the planchet. Dry filter, residue and dish in an oven at 103 – 105° C for at least one hour. Cool filter, residue and dish in a desiccator and then weigh filter, residue and dish together on an analytical balance. Repeat cycle of drying and desiccating until a constant weight is obtained or until the weight change is less than 4% of the previous weighing or 0.5 mg, whichever is less. Carefully record each drying/desiccating/ weighing on the TSS benchsheet.

### **Calculating TSS**

Using the initial and final weigh of the filter, dish and residue, calculate total suspended solids as illustrated in Figure 14.9.



$$\text{TSS (mg/L)} = \frac{(\text{Weight of filter, dish and dried residue} - \text{Weight of filter and dish}) \times 1,000,000}{\text{Sample volume, mL}}$$

**Figure 14.9 - Calculating Total Suspended Solids**

### TSS Quality Control

As is the case with all test methods, the TSS analysis' accuracy can only be relied upon when the methodology has been closely followed. In order to check the analyst's technique, run duplicate analysis on at least 10% of samples. Duplicate determinations should agree within 5% of their average. Externally supplied standards should be analyzed at least annually to verify the accuracy of the laboratory and analyst.

### TSS Benchsheet

Using the information given on Figure 14.10, the TSS benchsheet, calculate the TSS of the samples.

### pH PROCEDURE

Measurement of pH is one of the most important and frequently used tests in water/ wastewater analysis. Practically every phase of water supply and wastewater treatment is pH dependent. At a given temperature, pH indicates the *intensity* of the acidic or basic character of a solution. A solution's pH is the outcome of the balance between hydrogen ions (H<sup>+</sup>) and hydroxide (OH<sup>-</sup>) molecules, as well as its temperature. What is actually measured is the activity of hydrogen ions (H<sup>+</sup>). This measurement is then translated onto a scale that spans from 0 to 14 as the reciprocal of the logarithm of the hydrogen ion activity; - log [H<sup>+</sup>]. In general, pH values are reported to the tenth decimal in the standard units (S.U.) of the 0 to 14 scale.

Many laboratory procedures are pH dependent. Metabolic rates, organism reproduction rates, various chemical reactions and chlorine toxicity are all influenced by pH. Because of its effect upon so many aspects of water analysis, ACCURATELY MEASURING PH IS ONE OF THE CORNERSTONES THAT LABORATORY QUALITY ASSURANCE/ QUALITY CONTROL IS BUILT UPON.

Two methods for measuring pH values are approved by NMED and EPA for permit compliance reporting purposes. These are:

- EPA Methods For Chemical Analysis Of Water And Wastes, Method 150.1 (Electrometric Method)
- Standard Methods for the Examination of Water and Wastewater, 18<sup>th</sup>, 19<sup>th</sup> or 20<sup>th</sup> editions, Method 4500-H+ B. (Electrometric Method)

Both methods are electrometric, which involves the use of a pH probe from which the signal is read out upon a millivolt meter. Although both methods are acceptable (and very similar), this text specifically discusses Method 4500-H+ B from Standard Methods.

### pH Sample Collection and Handling

Samples to be analyzed for pH should be collected in 100 – 500 mL polypropylene sample bottles. There are no methods of preservation, therefore, all pH samples are grab samples and must be analyzed within 15 minutes of sample collection. The quicker the samples can be analyzed, the more accurate the result will be. In fact, for many process control applications, pH is measured in-situ, such as in wastewater treatment lagoons. Effluent samples that are analyzed for permit reporting purposes should clearly indicate the sample time as well as the time of analysis to verify that the 15-minute holding time was not exceeded.

### pH Meter and Calibration Buffers

Measurement of pH is made with a pH meter that consists of:

- A potentiometer (millivolt meter)
- A glass *sensing* electrode
- A *reference* electrode (half cell)
- A temperature compensating device

For routine work, the pH meter must be accurate and reproducible to the nearest 0.1 pH unit. Before use, the meter must be calibrated to at least two standards and then checked against a third standard. Most labs use calibration standards (known as buffers) that have pH values of 4.0, 7.0 and 10.0 at 25° C. Buffers with these values can be purchased that are color coded so that the buffer with pH value 4.0 is red, 7.0 is yellow and 10.0 is blue. The color-coding makes the buffers easier to identify while calibrating the pH meter.

### Calibration of pH meter

In a laboratory, pH meters are generally calibrated once in the morning and once in the afternoon. In the field, calibrate for each set of samples or whenever field conditions change. Calibrate to two points that bracket the expected sample pH and are at least 3 pH units apart using the following sequence:

- Ensure that the meter is on, the electrode is connected and all needed materials are present.
- Engage the instrument calibration mode.

Figure 14.10 - Total Suspended Solids Benchsheet

Name of Facility: New Mexico WWTF  
 Date of Sampling: 4/6/04 Time of Analysis: 10:15 AM  
 Time of Sampling: 10:00 AM Analyzed by: Joe T. Operator  
 Name of Sampler: Joe T. Operator Method Used: Method 2540 D., Standard Methods for the Examination of Water and Wastewater, 18th edition  
 Type of Sample: Grab  Comp   
 Flow at time of sampling: 0.88 MGD  
 Sample Preservation: none  
 Date of Analysis: 4/6/04

**SAMPLE DATA**

Sample Location(s):	Influent	Effluent	(Duplicate) Effluent	Blanks	
Dish Number	1A	1B	1C	2A	2B
Sample Volume (mL)	100	1000	1000	100	100
1 <sup>st</sup> Weight fo filter, dry residue & dish (grams)	1.0261	1.0217	1.0193	1.0005	1.0089
Weight of dry filter & dish (tare weight, grams)	1.0008	1.0015	1.0012	1.0004	1.0090
Weight of dry residue (grams)				0.0001	-0.0001
Time of 1 <sup>st</sup> weighing	11:30 AM	11:30 AM	11:31 AM	11:34 AM	11:35 AM
2 <sup>nd</sup> Weight fo filter, dry residue & dish (grams)	1.0258	1.0215	1.0192	1.0004	1.0089
Weight of dry filter & dish (tare weight, grams)	1.0008	1.0015	1.0012	1.0004	1.0090
Weight of dry residue (grams)				0.0000	-0.0001
Time of 2 <sup>nd</sup> weighing	1:20 PM	1:21 PM	1:21 PM	1:21 PM	1:23 PM
TSS (mg/L)				ND	ND
Average TSS (mg/L)		<i>(should be) 19.0</i>		Non-Detectable	

$$TSS, \text{ mg/l} = \frac{\text{Final Wt. grams} - \text{initial Wt. grams} \times 1,000,000}{\text{Sample Volume, ml}}$$

Note: Refrigerate sample at 4°C up to the time of analysis.

Key:

	calculate data in shaded blocks
--	---------------------------------

- Remove the electrode from its storage solution and rinse it with de-ionized water.
- Blot the electrode dry with a paper towel, (do not wipe).
- Immerse the electrode in pH buffer 7.0 (constantly mixed by a stir plate).
- Allow the meter to stabilize, record the reading.
- Calibrate the meter to buffer 7.0.
- Remove electrode from the 7.0 buffer, rinse with de-ionized water and blot dry with paper towel.
- Immerse the electrode in a second pH buffer (4.0 or 10.0).
- While mixing constantly with stir plate, allow the meter to stabilize and then record the reading.
- Calibrate meter to second buffer value.
- Remove the electrode from the second buffer, rinse it with de-ionized water and blot dry with paper towel.
- Immerse the electrode in the check pH buffer (buffer not yet used).
- While mixing, allow the meter to stabilize and then record the reading.
- The reading of the check buffer must be within 0.1 pH unit of actual value, if not, the calibration must be repeated.
- Remove the electrode from the buffer, rinse it with de-ionized water and blot dry with paper towel.
- The pH meter is now calibrated.

### Measuring Sample pH

Use sufficient sample volume to cover the electrode and give adequate clearance for a stir bar. Mix the sample constantly, but be cautious not to introduce CO<sub>2</sub> by overly rapid mixing (no vortex). Record the pH value when the reading is stable. Some pH meters indicate when the reading is stable with a light or through a “chirp”. Record the sample temperature to the nearest degree Centigrade (°C). Repeat measurement on another sample aliquot until values differ by < 0.1 pH unit.

Be aware that if the reading is not in the range bracketed by the calibration buffers used, the meter will need to be recalibrated using another buffer. For example, if you calibrated to the 7.0 and the 10.0 buffers, and then checked the calibration with the 4.0, the sample reading must be between 7.0 and 10.0. If the sample reading were below 7.0, you would need to go back and recalibrate to the 7.0 and the 4.0 buffers, and check the calibration with the 10.0 buffer.

### Quality Control For pH Measurements

- Equipment
  - Do not store electrodes dry. Store in solution indicated by manufacturer.
  - Maintain electrolyte in reference electrodes. Re-fill when volume is low.
  - Uncover fill hole of the reference electrode (if so equipped) so that electrolyte can flow freely.
- Buffers
  - Record buffer date of purchase, date opened and expiration date.
  - Purchase buffers in quantities that will be consumed within six months.
  - Buffers should be used before their expiration date.
  - Store buffers in the dark at room temperature.
  - Discard buffers that are not clear or that show growth.
- Samples Measurements
  - Meter must be calibrated with two buffers that bracket the sample pH.
  - Performance evaluations on externally supplied standards should be run at least once a year.

### TOTAL RESIDUAL CHLORINE PROCEDURE

Chlorine is a common wastewater disinfectant. Residual chlorine in effluent is toxic to fish in receiving streams and so must be removed with a *dechlorinating* chemical, such as sulfur di-oxide. Many NPDES permits place limitations on the amount of total residual chlorine (TRC) that can be discharged after dechlorination. Often, a permit will impose a limit of <0.019 mg/L or <0.011 mg/L TRC, although many permits require that “no-detectable” TRC be discharged. For most treatment plants, “no-detectable” TRC is equivalent to <0.099 mg/L.

There are three EPA approved test methods for measuring low-level TRC; (1) The Amperometric Titration method, (2) the Iodometric Electrode method and (3) The DPD Colorimetric method. This text focuses on the most commonly used method; the DPD Colorimetric, as described in Method 4500-Cl G., Standard Methods for the Examination of Water and Wastewater, 18<sup>th</sup> edition. The DPD method is a colorimetric method that takes advantage of the reaction that occurs between residual chlorine and *N,N-Diethyl-p-phenylenediamine* (DPD) indicator solution. When chlorine is present, a reaction with the DPD indicator results in the development of a pink coloration. The more chlorine present in a sample, the more intense the color development. Using a photometric device, the color intensity can be measured through absorption.



### **TRC Sample Collection and Handling**

Samples to be analyzed for TRC should be collected in clean 100 – 500 mL polypropylene bottles. Ensure that representative samples are taken, i.e.; peak flow, well mixed flow stream. NPDES permits specify the exact TRC sampling location (generally, following the last treatment process). Residual chlorine samples are not stable, and there are no preservation methods. TRC samples are subject to change from excessive holding times, exposure to sunlight, increase in temperature and agitation. Much like pH samples, TRC samples must be analyzed within 15 minutes (preferably less). Benchsheets should record both the time that the sample was collected and the time that it was analyzed to demonstrate that the holding time was not exceeded.

### **TRC Equipment**

The DPD method of measuring TRC can be performed on two different (but similar) instruments; (1) a spectrophotometer, and (2) a filter photometer. A spectrophotometer is a device that measures the absorption of light at various wavelengths. For TRC measurements using a spectrophotometer, a wavelength of 515 nm with a light path of a least 1cm is required. A filter photometer is a device that measures the absorption of light in a fixed range of wavelengths. For TRC measurements using a filter photometer, a wavelength range of 490 - 530 nm with a light path of a least 1cm is required.

### **Instrument Calibration**

Calibration to known standards is required for all photometric devices. The required frequency of calibration is dictated by individual circumstances. The recovery of known standards to check the instrument calibration is required as part of a quality control program. Because chlorine is unstable it cannot be used for making standards directly. Standards can be prepared either with Chlorine exposed Potassium Iodide (KI) or with Potassium permanganate (KMnO<sub>4</sub>). At least 5 calibration standards covering the Chlorine equivalent range of 0.05 – 4.0 mg/L should be used to prepare a calibration curve.

### **TRC Analysis**

- Assure that the instrument is set to the correct wavelength and that the optical sample cells are clean and not damaged.
- Measure appropriate volumes of buffer and DPD reagents into a graduated cylinder and fill with appropriate sample volume (usually 50 mL).
- Stopper the graduated cylinder.
- Mix the buffer, DPD reagent and sample by inverting several times and allow 3 minutes for color development.

- Using a matched optical sample cell filled with sample, zero the instrument.
- When color of sample cell with buffer and DPD reagent is developed (3 min.), place cell in instrument and read absorption. (Most modern instruments display a reading directly in mg/L TRC).
- Using distilled water, prepare a reagent blank that contains:
  - A blanking agent
  - Buffer and DPD
- Read the absorption of the reagent blank with the instrument.
- Subtract the reading obtained for the reagent blank from the reading obtained for the sample.
- This yields the corrected sample TRC.

### **Quality Control - Sample Preparation**

Samples containing significant turbidity should be filtered through a 3-micron membrane filter after reacting the sample with DPD reagent and buffer. When using this method, zero the instrument with a filtered sample blank.

### **Quality Control - Standard Recovery**

Periodically prepare standards from Chlorine reacted with KI or from KMnO<sub>4</sub>. Determine recovery of these standards and establish lower detection limit as the lowest standard that can be detected with 95% recovery.

### **Quality Control- Performance Evaluation Standards**

Externally supplied performance evaluation standards should be analyzed at least annually.

### **References**

Standard Methods for the Examination of Water and Wastewater, 18<sup>th</sup>, 19<sup>th</sup> and 20<sup>th</sup> editions  
Operation of Wastewater Treatment Plants, Volume 2, 4<sup>th</sup> ed., Chapter 16



# CHAPTER 15: SAMPLING AND REPORTING

## DISCHARGE MONITORING REPORTS (DMRS)

The sample collection and analytical results required by the effective permit (EPA or state issued) must be reported to the enforcement authority (EPA or state) through the submission of DMRs (EPA Form 3320-1). An original and one legible copy of the DMRs must be submitted to the enforcement authority by the date specified in the permit. This data is entered into a national database available to the public. *It is extremely important that the data reported on the DMR be accurate, timely, and legible to ensure the facility's compliance status is correctly reflected.* The reported data will be compared with the current limits contained in the permit or any enforcement order to determine facility compliance. It should be noted that a DMR is required even if the facility did not have a discharge during a reporting period.

## INSTRUCTIONS FOR COMPLETION

(See Figure 15.1)

1. Permittee Name/Address - Name and mailing address of permittee.
2. Facility/Location - Enter if different from mailing address.
3. Permit Number - The permit number usually consists of nine characters, alpha and numeric combined. Currently, the permit numbers begin with the two-digit alpha state abbreviation (EX: AR, etc.). For permits issued by the State of Texas (TPDES), the EPA ID Number is the permit number used for reporting purposes. Other variations of the permit number will be assigned to identify special programs (EX: storm water, oil and gas, sludge, etc.)
4. Discharge Number (Outfall Number) - Consists of a combination of four alpha and numeric characters. (EX: 001A, 002Q, 003S, 004Y). Some exceptions include, but are not limited to, biomonitoring/toxicity, and sludge. The first two characters are "TX" for biomonitoring/toxicity reporting and "SL" for sludge reporting. The last two characters are usually an assigned code used for Agency tracking purposes (EX: TX1A, TX1S, TX1Y, SLDP, SLSA, SLSF, etc.).
5. Monitoring Period - From first day of monitoring period through last day of monitoring period. The dates should be displayed as YR MO DAY. Applicable monitoring periods will be specified in each permit. Some examples include, but are not limited to:
  - Monthly - 02 01 01 to 02 01 31
  - Quarterly - 02 01 01 to 02 03 31
  - Semi-annual - 02 01 01 to 02 06 30
  - Annual - 02 01 01 to 02 12 31
6. No Discharge - Mark this block if the facility has no discharge for a specific outfall during the monitoring

period. Do not mark if the facility had a discharge but failed to sample.

7. Parameters - Specified in the permit as effluent characteristics for each discharge number (outfall), one parameter per box. Each box must display the parameter name and corresponding storet code number. (EX: BOD (00310), pH (00400), TSS (00530), flow (50050)). The parameters should display on the DMR form in numeric order by storet code number. **Consult the appropriate regulatory agency if any changes need to be made to the pre-printed or self-generated DMRs.**
8. Sample Measurement - Sample measurement data for each parameter under "Quantity or Loading" or "Quality or Concentration" in accordance with permit limitations. Indicate units (lbs/day, mg/L, su, etc) as specified in the permit. (See Appendix 4 - Definitions and Calculations for Discharge Monitoring Reports.) It may be necessary to do calculations to convert data to the units required in the permit. "Average" is normally arithmetic average (geometric average for bacterial parameters) of all sample measurements for each parameter obtained during the monitoring period. "Maximum" and "Minimum" are normally the highest and lowest measurements obtained during the monitoring period. (See Appendix B - Wastewater Math Formulas & Appendix C - Fecal Coliform, How to Calculate Geometric Mean.) **Consult the appropriate regulatory agency if any changes need to be made to the pre-printed or self-generated DMRs.**
  - a. No. EX (Number of Exceedance) - Total of sample measurements that exceed the daily maximum, daily minimum, 7-day (weekly) average permit limit. **DO NOT** include monthly average or daily average violations in this field. If none, enter "0". Permittees with continuous pH, or temperature monitoring requirements should consult the permit for what constitutes an exceedance and report accordingly.
  - b. Frequency of Analysis - **Actual** frequency of analysis used during the monitoring period; the minimum requirement is as specified in the permit. Enter "CONT" for continuous monitoring, "01/07" for one day per week, "01/30" for one day per month, "01/90" for one day per quarter, etc. Some examples are included in Table 15.1.
  - c. Sample Type - **Actual** sample type used during monitoring period. Enter "GRAB" for individual sample, "24HC" for 24-hour composite, "CONT" for continuous monitoring.

9. Permit Requirement - Effluent limitations for each parameter as specified in the permit are displayed on the DMR under "Quantity or Loading" and/or "Quality or Concentration". Monitoring requirements for frequency of analysis and sample type as specified in the permit are also displayed. The DMR must reflect the most current monitoring and reporting requirements. **Consult the appropriate regulatory agency if any changes need to be made to the pre-printed or self-generated DMRs.**
10. Name/Title Principal Executive Officer or Authorized Agent - See the permit for qualifications of Principal Executive Officer and signature authorization.
11. Signature - **Original** legible signature of authorized Principal Executive Officer or Authorized Agent. Every page of the DMR must have an original signature. In the event a revised or corrected DMR is necessary, an original authorized signature and date of signature is required on each page. The word **REVISED** should be clearly visible on each page of the form.
12. Telephone - Telephone number of Principal Executive Officer.
13. Date - **Actual date** of signature certifying authenticating data submitted on DMR.
14. Comments - May contain any clarifying information of permit requirements or reporting instructions.

1. Have an original authorized signature. Signatures from a carbon copy, photocopy, stamp, or computer scanner are not acceptable.
2. Date of new signature
3. Be clearly marked as a revised or corrected DMR
4. Revised data should be highlighted or otherwise clearly indicated.

#### SELF-GENERATED DMR FORMS

Before undertaking the task of generating self-monitoring reports, the facility should first contact their regulatory agency. In order to receive approval from EPA for use of a facility generated (self-generated) DMR form, a facility must submit an approval request with sample DMRs (clearly marked "SAMPLE" and not signed) reflecting permit requirements for each monitoring period and discharge number. The forms submitted for approval must be an exact replica of the DMRs provided by the Agency with printing no smaller than the type on the preprinted DMRs. **These facility-generated forms must not be used until Agency approval has been obtained.** If there is a change in monitoring or reporting requirements (EX: reissued permit), it will be necessary for the facility to revise their forms to reflect the changes and resubmit for approval. OMB Forms Approval Number in the upper right corner of the preprinted DMR and the form number and other information under the last solid line at the bottom of the DMR form should not be included on the facility's self-generated forms.

**NOTE:** The results of any additional monitoring of parameters at the location(s) designated in the permit, using approved analytical methods, must be included on the DMR. **THE MOST RECENT VERSION OF A DISCHARGE MONITORING REPORT (Figure 15.1) CAN BE FOUND AT:**

<http://www.epa.gov/region6/6en/w/dmr.htm>  
<http://www.epa.gov/region6/6en/w/dmr.pdf>

#### REVISED/CORRECTED DMRs

Sometimes it will be necessary for the facility to submit a revised or corrected DMR either because the Agency has requested it or the facility has discovered an error. Some reasons for submitting a revision/correction are:

1. Missing original or unauthorized signature
2. Missing NPDES Permit Number, Discharge Number (Outfall Number) and/or Monitoring Period
3. Missing sample measurements
4. Parameters not reported
5. Loading measurements not correctly calculated
6. Missing Frequency of Analysis, Sample Type and/ or Number of Excursions
7. Wrong monitoring period shown on DMR.

When a revised/corrected DMR is submitted, it **must**:

#### NON-COMPLIANCE REPORTS (NCRs)

The Permittee shall report any instances of non-compliance with their permit. See your permit for specific requirements for reporting anticipated non-compliance, 24-hour reporting of conditions which may endanger health and the environment (via phone, e-mail or fax) and other non-compliances which must be reported. This report must include the following information as indicated on Figure 15.2 - Sample Non-Compliance Report.

1. Type of violation  
Name of parameter and outfall, or description such as overflow/bypass.
2. Date of violation  
A date range is required for multi-date non-compliance reporting. If you have a 7 day violation, you must provide the first and last date of that 7 day monitoring period.
3. Duration of violation
4. Cause of violation
5. Corrective action/Health or Environmental Impact/ Preventative Measures/Other Narrative

The exact date and value of each occurrence for a minimum or maximum violation means to state the actual date the



**Figure 15.2 - Non-Compliance Report Form**



**EPA REGION 6 NPDES NON-COMPLIANCE REPORT FORM**



Facility Name: \_\_\_\_\_

NPDES Permit Number: \_\_\_\_\_

Name of Parameter & Description (e.g. TSS at Outfall 001, pH at Outfall 003, Sanitary Sewer Overflow at 123 Main St.)	Numeric Value (e.g., volume, concentration or load) (i.e., 67 mg/L daily max, 100 lbs/day or 100,000 gal)	Permit Limit (e.g. 45 mg/L)	Date of Violation	Duration of Violation	Cause of Violation (e.g., power failure, sludge pump failure)	Corrective Action/Health or Environmental Impact/Preventative Measures/Other Narrative (e.g., replaced pump, restored power, replaced backup generator, fish kill, applied disinfectant)

Reported by: \_\_\_\_\_ Date of Report: \_\_\_\_\_ Phone #: \_\_\_\_\_

Title: \_\_\_\_\_  
 You may enter your data online and print this form.  
 This is an optional form that you may alter for your own purposes.

**Signature**  
 I certify under penalty of law that this document and all attachments were prepared under my direction or supervision in accordance with a system designed to ensure that qualified personnel properly gather and evaluate the information submitted. Based on my inquiry of the person or persons who prepared the system, or those persons directly responsible for gathering the information, the information submitted is, to the best of my knowledge and belief, true, accurate, and complete. I am aware that there are significant penalties for submitting false information, including the possibility of fine and imprisonment for knowing violations.



**Table 15.1 - Frequency of Analysis**

<u>FREQUENCY</u>	<u>DESCRIPTION</u>	<u>FREQUENCY</u>	<u>DESCRIPTION</u>
N/A	NOT APPLIC	02/12	TWICE/12 DAYS
N/R	NOT REPORTD	02/30	TWICE/MONTH
N/V	NOT VALID	02/90	TWICE/QTRLY
01/07	WEEKLY	03/DS	THREE/DISCHG
01/14	ONCE/2 WEEKS	03/DW	3 DAYS/WEEK
01/21	ONCE/3 WEEKS	03/07	THREE/WEEK
01/28	ONCE/4 WEEKS	03/30	THREE/MONTH
01/30	ONCE/MONTH	04/07	FOUR/WEEK
01/90	QUARTERLY	04/30	FOUR/MONTH
02/DS	TWICE/DISCH	05/07	WEEK-DAYS
02/DW	TWICE/DSCHWK	05/WK	5 TIMES/WEEK
02/YR	SEMI-ANNUAL	05/99	SEE PERMIT
02/07	TWICE/WEEK		

sample is taken and the value derived from the sample that exceeds the limit. If the sample exceeds the limit more than once in a monitoring period, indicate each sample and value for that period.

**BYPASS/OVERFLOW/UPSET REPORTS**

(Twenty-Four Hour Reporting)

A bypass, an overflow and an upset condition are all deviations from the permit conditions and as such are subject to reporting conditions. If any noncompliance endangers health or the environment, it should be reported orally within 24 hours from the time the permittee becomes aware of the circumstances. A written submission shall be provided within 5 days of the time the permittee becomes aware of the circumstances.

The report shall contain the following information:

1. A description of the noncompliance and its cause;
2. The period of noncompliance including exact dates and times, and if the noncompliance has not been corrected, the anticipated time it is expected to continue; and,
3. Steps being taken to reduce, eliminate, and prevent recurrence of the noncomplying discharge.

The 24-hour verbal report shall include:

1. Any unanticipated bypass, which exceeds any effluent limitation in the permit.
2. Any upset which exceeds any effluent limitation in the permit.
3. Violation of a maximum daily discharge limitation for any of the pollutants listed by the Director in Part

II (industrial permits only) of the permit to be reported within 24 hours.

**SCHEDULES/REPORTS**

In addition to DMRs and non-compliance reports (NCRs), the permit or formal enforcement actions may contain additional reporting provisions, with specific reporting requirements. These specific provisions could include compliance schedules with progress reports, pretreatment requirements, toxicity, sludge, storm water, etc. The actual completion date of any scheduled activity must be included in the submitted report and the report is due within 14 days of the scheduled activity. Any report which indicates noncompliance with a scheduled event should include the reason for the delay, what actions are being taken to get back on schedule, and how the delay will affect the remaining schedule events. See the permit or formal enforcement action for specific reporting dates and requirements.

**SLUDGE REPORTING REQUIREMENTS**

Federal regulations contained in 40 CFR Part 503 are self implementing (i.e., compliance is required regardless of whether a permit contains the conditions). An updated version of the regulations can be found at EPA Region 6, web page

<http://www.epa.gov/earth1r6/6en/w/sludge.htm>.

The regulations require all Publicly Owned Treatment Works (POTWs) servicing a population greater than 10,000 or having a design flow rate greater than one million gallons per day, or designated as Class I facilities to submit an annual report to the permitting authority every year on February 19th.

Annual sludge reports required by 40 CFR Parts 503-18, and 503-28, are due to the regulatory agency by either February 19th or September 1st of each year as specified in your permit. EPA Region 6, is the sludge regulatory authority for the States of Arkansas, Louisiana, and New Mexico. If you require assistance for completing the DMRs, or if you have questions regarding sewage sludge compliance with the Part 503 requirements, please contact the EPA Regional Sludge Coordinator at 214-665-6475.

The basic set of sludge DMR forms consist of: Production and Use (Outfall SLDP); Land Application (Outfall SLLA); Surface Disposal (Outfall SLSA); and, Landfilling (Outfall SLDF). See the permit for additional outfalls required for specific sludge disposal operations. The entire set of forms must be appropriately completed (with facility name, address, NPDES number and appropriate monitoring periods) and each form must include an original signature. The original and one copy of the completed and signed reports must be mailed to the appropriate agency.

#### **FREQUENCY OF ANALYSIS/MONITORING PERIOD**

##### **Production & Use Forms**

The reporting year begins on January 1 and ends on December 31 each year, with reports due on February 19th. The reporting year begins on August 1 and ends on July 31st each year for reports due on September 1st.

##### **Land Application & Surface Disposal Forms**

Facilities must indicate the actual frequency that sewage sludge is monitored in the "Frequency of Analysis" column. The minimum required frequency, indicated in Tables 1 of Parts 503.16 and 503.26, is dependent on the amount of sludge which is annually land applied or surface disposed, respectively.

A separate report shall be made and completed for EACH MONITORING PERIOD, and the appropriate monitoring period, dates must be indicated at the top of the DMR form. For example, if a facility is required to monitor once per quarter, four monitoring reports must be completed for each full reporting year.

In order to aid in processing reports for multiple monitoring periods, facilities should indicate "Monitoring Period 1, Monitoring Period 2, Monitoring Period 3, etc..." in the comments section at the bottom of the DMR form for each of the separate reports.

**NOTE: Frequency and sample type must be completed on every DMR form, except when "no discharge" is indicated.**

#### **Additional Reporting Requirements**

In addition to the DMR forms, facilities which land apply or surface dispose of sewage sludge are responsible for submitting the additional information required in Parts 503.18 or 503.28, respectively; i.e., appropriate certification statements, descriptions of how the management practices in Parts 503.14 or 503.24 are being met, and descriptions of how the site restrictions (if applicable) in Part 503.32(b)(5) are being met. This information must be attached to the original copy of the DMR forms when submitted to the regulatory agency.

Facilities which dispose of sewage sludge by incineration are required to provide the information required in Part 503.48 in addition to the DMR forms.

#### **Completion of DMR Forms**

The following instructions are for use in completing the basic set of sludge DMR forms. **All fields must be completed, including frequency of analysis and sample type. This is a summary of total sludge produced and the amount and method of disposal. All numeric values must be reported unless "not applicable" is indicated.**

##### **Production & Use DMR (SLDP)**

This form is to be completed by all major and/or designated Class I facilities which generate sewage sludge. The annual production and use information must be reported in metric tons per year (MT/yr); other information shall be in the units indicated. If a particular sludge use does not apply to the facility's practice, then this must be indicated with a "0".

##### **■Storet 39516: Polychlorinated Biphenyls (PCBs)**

Facilities which generate or prepare sewage sludge must indicate the concentration of PCBs (in mg/Kg) in the sludge. This parameter may be reported as N/A if sludge is not applied to facility during the monitoring period.

##### **■Storet 46390: Toxic Characteristic Leaching Procedure (TCLP)**

Facilities which generate or prepare sewage sludge must indicate the results of the TCLP test on the sludge. If the sludge has passed the test, the form must be indicated with a "0" (Pass). If the sludge does not pass the test, the form must be indicated with a "1" (Fail). This parameter may be reported as N/A if sludge is not applied to facility during the monitoring period.

##### **■Storet 49017: Annual Sludge Disposed by Other Methods**

Facilities must indicate the amount of sewage sludge prepared and used or disposed by a method other than

land application, surface disposal, incineration or co-disposal in a municipal solid waste landfill. Facilities which provide sewage sludge to another facility which further prepares the sludge, or changes the quality of the sludge, prior to land application, must report the amount provided to the other facility. The method of disposal or use other than those already indicated must be further described in the "Comments" section of the form. This parameter requires data showing the annual amount of sludge production and disposal; or, if none, report a zero (0).

**■Storet 49018: Annual Sludge Incinerated**

Facilities must indicate the amount of sewage sludge prepared and disposed by incineration in a sewage sludge incinerator. This parameter requires data showing the annual amount of sludge production and disposal; or, if none, report a zero (0).

**■Storet 49019: Annual Sludge Production**

Facilities must indicate the amount of sewage sludge produced after final sludge treatment for the reporting period. This parameter requires data showing the annual amount of sludge production and disposal; or, if none, report a zero (0). If this parameter shows sludge was produced, the appropriate parameter must be completed showing how the produced sludge was disposed; i.e.:

- 1) by other methods (storet 49017) requires stating what method was used in the comments section)
- 2) incinerated (storet 49018)
- 3) land applied (storet 49020) requires values be reported on the SLLA DMR accordingly. It is important to review your instructions to determine what monitoring frequency is required if sludge was land applied; i.e.
  - a) <290, frequency of analysis for SLLA is once per year
  - b) 290 to <1500, frequency of analysis for SLLA is once per quarter
  - c) 1500 to <15,000, frequency of analysis for SLLA is once every two months
  - d) 15,000 and over, frequency of analysis for SLLA is once per month
- 4) surface disposal (storet 49021) requires values be reported on the SLSA DMR accordingly. It is important to review your instructions to determine what monitoring frequency is required if sludge was surface disposed; i.e.:
  - a) <290, frequency of analysis for SLSA is once per year
  - b) 290 to <1500, frequency of analysis for SLSA is once per quarter

- c) 1500 to <15,000, frequency of analysis for SLSA is once every two months
  - d) 15,000 and over, frequency of analysis for SLSA is once per month
- 5) landfilled (storet 49022) requires completion of the SLDF DMR, or
  - 6) transported interstate (storet 49023)

**■Storet 49020: Annual Sludge Land Applied -**

Facilities must indicate the amount of sewage prepared and beneficially reused by land application. Facilities which provide sewage sludge to another facility which further prepares the sludge prior to land application need not report that amount of sludge which it has not prepared. This parameter requires data showing the annual amount of sludge production and disposal; or, if none, report a zero (0).

**■Storet 49021: Annual Sludge Surface Disposed -**

Facilities must indicate the amount of sewage prepared and disposed in a surface disposal unit. This parameter requires data showing the annual amount of sludge production and disposal; or, if none, report a zero (0).

**■Storet 49022: Annual Sludge Landfilled -**

Facilities must indicate the amount of sewage sludge prepared and co-disposed in a municipal solid waste landfill. This parameter requires data showing the annual amount of sludge production and disposal; or, if none, report a zero (0).

**■Storet 49023: Annual Sludge Transported Interstate -**

Facilities must indicate the amount of sewage sludge prepared and transported to another state other than the one in which it was prepared for eventual use or disposal. This parameter requires data showing the annual amount of sludge production and disposal; or, if none, report a zero (0).

**Land Application of DMR (SLLA)**

This form is to be completed by those facilities which prepare bulk sewage sludge for land application, for beneficial reuse, or sold or given away in a bag or other container. This form does not apply to those facilities which provide all of their sewage sludge to another facility which changes the quality of the sludge prior to land application.

**NOTE:** Modifications to the regulation, published in the October 25, 1995, Federal Register, removed chromium from the list of regulated pollutants for land application, and relaxed the limitations for selenium in land applied sludge.

**■Pollutant Table from 503.13 -** The facility must indicate the pollutant table from Part 503.13 which is



used to determine compliance with pollutant quality as follows:

**Table 2** - Used if bulk sewage sludge exceeds the Pollutant Concentrations of Table 3

**Table 3** - Used if bulk sewage sludge or sewage sludge sold or given away in a bag or other container of one metric ton or less meets (does not exceed) the Pollutant Concentrations of Table 3.

**Table 4** - Used if sewage sludge is sold or given away in a bag or other container of one metric ton or less, does not meet the Pollutant Concentrations of Table 3, and contains a label or information sheet indicating an annual whole sludge application rate which does not cause any of the Annual Pollutant Loading Rates in Table 4 to be exceeded.

■ **Metals** - The information to be included in this portion of the form consists of three types:

- 1) The cumulative loadings of the metals for a particular site (Kg/Ha)
- 2) The monthly average concentrations of metals (mg/Kg)
- 3) The maximum concentrations of the metals (mg/Kg).

All facilities which land apply bulk sewage sludge, sell, or give away sewage sludge in a bag or other container for land application must indicate the maximum concentration for all metals during the monitoring period in the "Maximum Concentration" column. These concentrations are limited by the values of Table 1 of Part 503.13.

The "Average Concentration" information must be completed by those facilities whose sludge meets the Table 3 Pollutant Concentrations. This information must reflect the monthly average concentration during the monitoring period. Facilities which do not use the Pollutant Concentration limits for compliance must indicate this column with "0" to reflect "Not Applicable".

**NOTE:** For purposes of reporting sludge concentration and loading, analytical values below detection limit shall be reported as "< x", where "x" represents the detection limit.

For those facilities whose sludge does not meet the Pollutant Concentrations of Table 3 and which are subject to the cumulative loading rates of Table 2, the cumulative loading of the metals at a site must be reported in the "Maximum Loading" columns if the loading rate has reached 90% or more of the maximum

rate allowed by Table 2 of Part 503.13. If the facility has more than one application site, then this form must be included for each site which has reached 90% or more of the maximum rate allowed. Facilities which do not use the cumulative loading rates must indicate this column with a "0" to reflect "Not Applicable".

**NOTE:** For purposes of reporting sludge concentration and loading, analytical values below detection limit shall be reported as "< x", where "x" represents the detection limit.

Level of Pathogen Requirement Achieved - Facilities must indicate the level of pathogen requirements achieved, if any. If the sludge meets the Class A requirements, the form must be indicated with a "1". If the sludge meets the Class B requirements, the form must be indicated with a "2". If the facility's sludge does not meet either the Class A or Class B levels, the facility must report "0" (None).

■ **Pathogen Alternative Used** - Facilities must indicate which alternative number is used to achieve the pathogen level indicated above. The alternative numbers are given in Part 503.32(a)(3) - (8) for Class A (#1-6) and Part 503.32(b)(2) - (4) for Class B (#1-3). For those facilities which have been issued a permit containing the new requirements under Part 503, the alternative numbers are given in Section I.B.3. of the permit. If the facility's sludge does not meet either of the pathogen reduction levels, it must report "0".

■ **Vector Attraction Reduction Alternative Used** - Facilities must indicate which alternative was used to achieve the vector attraction reduction requirement. The alternative numbers which apply to land application (#1-10) are given in Part 503.33(b)(1) - (10). For those facilities which have been issued a permit containing the new requirements under Part 503, the alternative numbers for vector attraction reduction are given in Section I.B.4. of the permit. If a facility is unable to meet any of the vector attraction reduction alternatives, it must report "0".

■ **Annual Whole Sludge Application Rate** - Facilities whose sewage sludge does not meet the Pollutant Concentrations of Table 3, which sell or give away sludge in a bag or other container as defined by Part 503, and which include (with the sludge) a label or information sheet containing an annual whole sludge application rate which does not cause any of the annual pollutant loading rates in Table 4 to be exceeded, must include that rate in this portion of the form. If this information does not apply to the facility, then it must indicate "0" to reflect "Not Applicable".



This DMR must be completed with values if any value other than “0” was shown on the SLDP DMR for parameter with storet 49020. If parameter storet 49020 on the SLDP DMR was reported as “0”, the No Discharge box should be marked at the upper right portion of the DMR.

#### **SURFACE DISPOSAL DMR (SLSA)**

##### **Storet 49028: Unit With Liner/Leachate Collection System**

Facilities must indicate the presence of a liner and leachate collection system in the surface disposal unit. A unit with a liner is indicated with “1” (Yes). A unit without a liner is indicated with “0” (No).

##### **Storet 49029: Unit Boundary to Property Line**

Facilities whose sewage sludge unit does not have a liner and leachate collection system must indicate the actual minimum distance (in meters) from the sewage sludge unit boundary to the property line of the surface disposal site.

##### **Storets 78469 and 78473: Metals Concentrations**

Facilities whose sewage sludge unit does not have a liner and leachate collection system must indicate the allowed pollutant concentrations for Arsenic, Chromium and Nickel from Tables 1 or 2 or Part 503.23., based on the unit boundary to property line distance. The allowed concentration must be entered into the “Average Concentration” column of the form. The actual maximum concentration measured by the permittee must be entered into the “Maximum Concentration” column of the form.

Facilities whose sewage sludge unit has a liner and leachate collection system need not indicate the pollutant concentrations but must indicate “0” to reflect “Not Applicable” in both the Average (allowed) and Maximum (actual) columns for the three pollutants.

##### **Storet 84368: Level of Pathogen Requirement Achieved**

See Land Application procedures above.

##### **Storet 84369: Pathogen Alternative Used**

See Land Application procedures above.

##### **Storet 84370: Vector Attraction Reduction Alternative Used**

Facilities must indicate which alternative was used to achieve the vector attraction reduction requirement. The alternative numbers which apply to surface disposal (#1 through #11) are given in Part 503.33(b)(1) - (11). For those facilities which have been issued a permit containing the new requirements under Part 503, the alternative numbers for vector attraction reduction are given in Section I.B.4.

of the permit. If a facility is unable to meet any of the vector attraction reduction alternatives, it must report “0”.

This DMR must be completed with values if any value other than “0” was shown on the SLDP DMR for parameter with storet 49021. If parameter storet 49021 on the SLDP DMR was reported as “0”, the No Discharge box should be marked at the upper right portion of the DMR.

#### **LANDFILLING DMR (SLDF)**

##### **Storet 49030: In Compliance With Part 258 Requirements for Sludge**

Facilities which generate sewage sludge that is co-disposed in a municipal solid waste landfill must indicate whether the sludge meets the requirements of 40 CFR Part 258 (passes TCLP and paint filter test). If the facility’s sludge meets the requirements, it must report “1” (Yes). If the facility’s sludge does not meet the requirements, it must report “0” (No).

This DMR must be completed if any value other than “0” was shown on the SLDP DMR for parameter 49022. If parameter 49022 on the SLDP DMR was reported as “0”, the No Discharge box should be marked at the upper right portion of the DMR.

#### **BIOMONITORING/TOXICITY**

The Permittee must test the effluent for toxicity in accordance with the provisions specified in their permit. Such testing will determine if an effluent sample dilution affects the survival, reproduction or growth of the appropriate test organism.

#### **VALID TEST**

A valid test must be performed and data submitted on a Discharge Monitoring Report (DMR) for each species required to be tested during the monitoring period specified in the permit. A valid test is defined as any test which satisfies the test acceptability criteria, procedures, and quality assurance requirements specified in the test methods and permit. All reports, tables, plans, summaries, and related correspondence required by your permit shall be prepared and/or submitted to the appropriate regulatory agency (EPA or State).

#### **DMRs**

If Agency provided preprinted DMRs have not been received for the initial test, or if the permittee has other questions regarding the monitoring periods, parameter codes, etc., the regulatory agency should be contacted for instructions. Discharge Numbers for Toxicity DMRs, such as TX1A, TX2Q, TX3Y, etc, are identified usually as follows:

- TX - indicates Toxicity reporting
- 1, 2 or 3 - indicates which outfall is being tested for toxicity.
- A, Q or Y - indicates if a test is to be conducted monthly (A), quarterly (Q) or yearly (Y).

Toxicity data is reported on the appropriate DMRs, for example:

- Pass/Fail (1 = Failure, 0 = Pass)
- NOEC value for Survival (Percent)
- NOEC value for Reproduction (Percent)
- % Mortality at Critical Dilution (Percent)
- % Coefficient of Variation (Percent), etc.

### INVALID TEST

An invalid test is defined as any test which does not satisfy the test acceptability criteria, procedures, and quality assurance requirements specified in the test methods and permit. A REPEAT Test shall be conducted within the reporting period of any test determined to be invalid.

### RETESTS

The permittee shall perform a total of two (2) additional tests (Retests) as a result of a previously failed test. The retests shall be conducted as outlined in the permit. If one or both of the two retests demonstrates significant lethal effects at or below the critical dilution, the permittee shall initiate Toxicity Reduction Evaluation (TRE) requirements as specified in the permit.

### TRE

A TRE is an investigation intended to determine those actions necessary to achieve compliance with water quality-based limits by reducing an effluent's toxicity to an acceptable level. The permittee shall submit a Action Plan and Schedule for conducting the TRE. The Action Plan shall specify the approach and methodology to be used in performing the TRE. The permittee shall submit quarterly activity reports concerning the progress of the TRE.

Based upon the results of the TRE and proposed corrective actions, the permit may be amended to modify the biomonitoring requirements where necessary, to require a compliance schedule for implementation of corrective actions, to specify a Whole Effluent Toxicity (WET) limit, to specify a Best Management Practice (BMP), and/or to specify Chemical Specific Effluent Limits.

### WET

Failure to identify the specific chemical compound causing toxicity test failure will normally result in a WET permit limit and will be reported on a DMR as Parameter 22414.

### Reference

NPDES Reporting Requirements Handbook,  
US Environmental Protection Agency Region 6, August 2004

## MOST COMMONLY ASKED QUESTIONS

### 1. HOW DO I REPORT "TOO NUMEROUS TO COUNT" (TNTC) COLIFORM SAMPLES?

■ Using Standard Methods 9222 D, 18th - 20th Edition  
If the Standard Methods 9222 D analysis procedure results in a colony count greater than 60, or is not distinct enough for accurate counting, on the membrane with the smallest filtration volume, report TNTC on the DMR form if only a single sample was collected for the reporting period (i.e. once a week sample for the 7-day geometric mean or a Daily Maximum). A TNTC reported on the DMR exceeds the permit limit and is considered a permit violation. However, actual numbers are required by the permit and should be reported whenever possible, and a broader dilution range should be adopted to ensure that a reportable fecal coliform count is obtained in future samples.

However, when calculating the 30-day geometric mean or a 7-day geometric mean with multiple sample results within each reporting period, the TNTC fecal coliform plate sample should be estimated as a ">" (greater than) value by dividing 60 by the smallest filtration value by using the formula in Figure 15.3 - Fecal Coliform Count:

$$\frac{\text{No. of Fecal Coliform Colonies Counted}}{\text{Volume in mL of Sample Filtered}} \times 100 = \text{Fecal coliform count / 100 mL}$$

**Figure 15.3 - Fecal Coliform Count**

i.e., for a 0.1 mL volume filtered  $60/0.1 \times 100 = 60,000$

Calculate as: >60,000 fecal coliforms/100 mL.

Table 15.2 is based on a sampling schedule of 7x/week, using the optimum range for colony plate count (20 - 60 colonies) and sample filtration volumes of 100 mL, 10 mL, 1.0 mL, and 0.1 mL (the smallest filtration volume of 0.1 mL):

**Table 15.2 - Example Fecal Coliform Plate Count**

Monday	200 colonies (20 colonies/10 mL x 100 = 200 colonies/100 mL)
Tuesday	600 colonies (60 colonies/10 mL x 100 = 600 colonies/100 mL)
Wednesday	TNTC = >60,000 colonies based on smallest filtration volume of 0.1 mL and using 60 colonies as the basis of calculation
Thursday	3000 colonies (30 colonies/1.0 mL x 100 = 3000 colonies/100mL)
Friday	500 colonies (50 colonies/10 mL x 100 = 500 colonies/100 mL)
Saturday	400 colonies (40 colonies/10 mL x 100 = 400 colonies/100 mL)
Sunday	200 colonies (20 colonies/10 mL x 100 = 200 colonies/100 mL)

The 7-day fecal coliform geometric mean would be calculated by multiplying the seven values 200 x 600 x 60,000 x 3000 x 500 x 400 x 200 and taking the seventh root of the multiplication factor which equals 979. If (as in this case) the geometric mean contained 1 or more greater than (>) values, the final average should be reported as >979.

#### ■ USING EPA METHOD, PAGE 124

If the EPA method Part III. Section C Fecal Coliform Methods (page 124) analysis procedure results in uncountable membranes with more than 60 colonies, use 60 colonies as the basis of calculation with the smallest filtration volume as illustrated above. A TNTC report is not allowed, but rather the result is reported as a ">" value by dividing 60 by the smallest filtration value, i.e.. 0.1 mL:  $60/0.1 \times 100 = 60,000$

Calculate and/or report as: >60,000 fecal coliforms/100 mL.

Again, a broader dilution range may need to be adopted to ensure that a reportable fecal coliform count is obtained in future samples.

## 2. HOW DO I COUNT NUMBER OF EXCEEDANCE?

If daily maximum/daily minimum, count each sample that is below and/or above the minimum/maximum limit.

If a 7-day average or weekly limit, every 7-day average which exceeds the limit in the permit shall be counted as one exceedance.

**DO NOT INCLUDE 30-DAY AVERAGES OR DAILY AVERAGES AS EXCEEDANCES ON DMR.** This exceedance is already included in the above calculations.

## 3. HOW DO I CALCULATE AND REPORT 7-DAY AVERAGES?

We recognize that calendar weeks and calendar months rarely coincide. Therefore, for the purpose of calculating and reporting 7-day averages, you should use the following process:

- Define your week (SUN-SAT, MON-SUN, etc.).

- Calculate the averages of all sample data obtained for each week.
- The highest calculated weekly average will be reported on the DMR for the month in which (1) the week ends or (2) the week begins, or (3) the month which contains the greatest number of days. It is the choice of the facility. However, the choice should be consistent month to month, year to year. SET A RULE AND STICK WITH IT.

## 4. WHO CAN SIGN A DMR?

The definition of authorized signatory official can be found in your permit, and in the regulations at 40 CFR 122.22 and 40 CFR 403.6(a)(2)(ii). In general, it is a responsible corporate official (e.g., officer of the corporation), partner, sole proprietor, or, for a governmental entity, a principal executive officer or ranking elected official. See the permit or regulations for the complete definition.

#### ■ CAN SIGNATORY AUTHORITY BE DELEGATED?

Yes. A duly authorized representative of a signatory official may also sign DMRs, or other NPDES reports, if such authorization has been made in writing by an authorized signatory official. The authorization must specify either an individual or a position having responsibility for the overall operation of the regulated facility or activity, it must be submitted to the permitting authority, and it must be certified by an authorized signatory official. See 40 CFR 122.22(b). Additionally, a sample delegation letter is available online and linked off of the following web page: [www.epa.gov/region6/gen/w/dmr.htm](http://www.epa.gov/region6/gen/w/dmr.htm).

## 5. DO I HAVE TO SIGN EACH PAGE OF MY DMR?

Yes. Each page must be signed. If any revisions are submitted, that revised page must also have an original signature and new signature date.

## 6. I RECEIVED A LETTER FROM EPA TELLING ME THAT THE STATE HAS NPDES AUTHORITY. DO I HAVE TO SEND ANY MORE REPORTS TO EPA?

Once you have received a letter from EPA transferring enforcement authority for your facility to an approved

NPDES state, you no longer need to send DMRs, non-compliance reports, etc., to EPA, unless you receive a specific request or action from EPA.

## 7. HOW DO I REPORT EFFLUENT DATA BELOW DETECTION LIMIT?

Unless otherwise stated in the permit, values below the detection limit are to be reported with a less than symbol (<) and the numeric value for the detection limit using the EPA approved method.

Where the permit contains a listing of Minimum Quantification Levels (MQLs) and the permittee is granted authority in the permit to report zero in lieu of the <MQL for a **specified parameter**, (conventional, priority pollutants, metals, etc.) then zero is to be reported for that parameter.

In some cases the permittee has been granted by letter the authority to report zero when the permit does not contain this language. The permittee may request this authorization from its regulatory agency.

Where authority has not been granted to report zero, the less than MQL values are to be averaged with the numbers greater than the MQL and report the calculated average using the less than symbol.

For Example:

MQL is 3 mg/L, 4 sample results in a month: <3, 5, <3, 7.

The Monthly Average =  $(3 + 5 + 3 + 7)/4 = 4.5$

Report on the DMR for Monthly Average as “<4.5”

Some permittees have complained that the MQL concentration for a parameter results in a loading calculation they believe is higher than they actually have. Unless one of the provisions discussed above applies, allowing you to use “0” for your calculation, you are to use the MQL concentration for calculating the loadings for results that are below the MQL. The only way to improve the loadings calculation is to switch to another approved method that has a lower MQL.

## 8. HOW DO I ROUND NUMBERS AND RATIOS?

Permits sometimes require the rounding of numbers or ratios. These numbers or ratios should be rounded as follows:

- (a) If the digit 6, 7, 8, or 9 is dropped, increase preceding digit by one unit.

Example: a calculated parameter of 1.06 should be rounded to 1.1 and reported as a violation of the permit limit if the permit limit is 1.0.

- (b) If the digit 0, 1, 2, 3, or 4 is dropped, do not alter the preceding digit.

Example: a calculated parameter of 1.04 should be rounded to 1.0 and reported to EPA as compliant with the permit limit if the permit limit is 1.0.

- (c) If the digit 5 is dropped, round off preceding digit to the nearest even number.

Example: a calculated ratio of 1.05 should be rounded to 1.0 and reported to EPA as compliant with the permit limit if the permit limit is 1.0.

This method of rounding numbers and ratios is consistent with the EPA rounding method recommended by EPA Headquarters’ L. Y. Boornazian and M. T. Flores Oct 10, 2003, memo.



# CHAPTER 16: STATE AND FEDERAL REGULATIONS

---

## ORIGIN OF ENVIRONMENTAL, SAFETY AND HEALTH REGULATIONS

In the past, state and federal governments did not regulate the disposal of domestic and industrial wastewaters. This situation led to disposal practices that left much to be desired. Municipal wastewater was simply dumped into rivers and lakes and industrial wastes were buried, discharged to surface waters and even pumped underground. Because of the sparse population of our state and the fact that most of our rivers are fast flowing, the pollution problems of the past were not always as obvious as in heavily populated states with slow moving rivers and estuaries. Whether obvious or not, environmental pollution problems are the result of allowing un-restricted practices. The laws that have been enacted by the state and federal governments for the purposes of environmental protection represent the recognition by the society at large that it is in our best interest to protect the quality of our air, soil and water.

Along these same lines, laws have been developed to protect workers from unsafe conditions on the job. In the United States in the past, (and in other countries today), there were no safety protections for workers. This often left employees in the position of working in unsafe conditions or finding another job. Now laws are in place to protect employees from hazards associated with their work. These protections are particularly important to wastewater treatment plant operators and wastewater collection system operators because of the danger inherent in these professions.

What follows is an overview of the environmental, safety and health regulations that pertain to the wastewater treatment field. This overview is not intended for regulatory decision-making. For the purposes of meeting regulatory requirements, refer to the actual statute.

## FEDERAL CLEAN WATER ACT

The Clean Water Act (CWA) is the legislative basis for federal water pollution control regulations. Originally passed in 1972 as the Federal Water Pollution Control Act, the primary stated goal of the CWA is to “restore and maintain the chemical, physical and biological integrity of the nation’s waters”. One aim of the CWA was to make all of the nation’s waters “fishable and swimmable” by 1983. Much progress has been made toward the goals, but much more work needs to be done.

The primary elements of the CWA include:

- A system of minimum national effluent standards based upon available treatment technology;

- A system of water quality standards;
- A discharge permit program, known as the National Pollutant Discharge Elimination System (NPDES), which provides enforceable limitations on dischargers;
- A set of provisions for special problems such as toxic chemicals and oil discharges; and
- A construction grant/loan program for Publicly Owned Treatment Works (POTWs).

Wastewater treatment systems that discharge into surface waters of the United States are required by the CWA to have a NPDES permit. NPDES permits require a minimum level of treatment (based upon secondary treatment processes). Other limitations may be imposed if it is deemed necessary to protect the water quality of the receiving waters. Most states have enacted laws that give the state the authority to issue NPDES permits. This is known as “primacy”. However, in New Mexico NPDES permits are issued by the Environmental Protection Agency (EPA) region VI out of Dallas TX because NM has never enacted the legislation that is necessary for the state to seek primacy. NPDES permits are typically issued for a period of five (5) years. Application for renewal is the responsibility of the permit holder.

The limitations set forth in individual NPDES permits can vary, although the vast majority issued to dischargers in NM follow the standard limitations outlined in Table 16.1. In addition to the limitations outlined in Table 16.1, limitations are placed on the **loading** of BOD and TSS that can be released into the receiving stream (measured in lbs./day).

The NPDES permitting program provides for “self monitoring”. This means that the permit holder can perform the laboratory tests used to prove permit compliance in their own laboratory provided the tests are done in accordance with specific methods. Most medium to large treatment plants in New Mexico with NPDES permits perform self monitoring, while the smaller plants use contract laboratory services to analyze some or all of their effluent samples. The results of effluent monitoring samples are reported to the NMED-Surface Water Quality Bureau (NMED-SWQB) and EPA in Dallas on a quarterly basis on a form known as a discharge monitoring report (DMR).

NPDES permits also provide for inspection of the treatment works and collection of compliance verification samples by the issuing agency. In New Mexico, the NMED Surface Water Quality Bureau (NMED-SWQB) contracts with EPA

Parameter	30-Day Average	7-Day Average	Maximum	Minimum
Flow	Report	NA	Report	NA
BOD, mg/L	<30	<45	NA	NA
TSS, mg/L	<30	<45	NA	NA
Fecal Coliform, organisms/100ml	<500	NA	NA	NA
pH	NA	NA	9.0	6.0
Total Residual Chlorine, mg/L	NA	NA	<0.099 or "non-detectable"	NA

**Table 16.1 - Standard NPDES Limitations**

to perform compliance inspections and EPA performs some compliance inspections of its own. The types of permit violations that can be identified during an inspection include: failure to practice proper sampling, monitoring and reporting, failure to properly operate and maintain the treatment works, failure to properly perform laboratory analysis of reporting samples, allowing industrial wastes to be discharged into the collection system, and improper sludge disposal/re-use practices. Permit violations can result in fines and even criminal prosecution.

## **NEW MEXICO ENVIRONMENTAL PROTECTION LEGISLATION**

The state of New Mexico has enacted a variety of laws designed to protect our land, air and water. These environmental protection laws are promulgated in the New Mexico Administrative Code (NMAC), Title 20.

### **NMAC, TITLE 20, CHAPTER 6, PART 2**

The regulations for the protection of ground and surface waters are found under NMAC, Title 20, Chapter 6, Part 2. Because our state does not have primacy with regard to the CWA, surface water dischargers receive their permits from EPA. Systems that discharge to ground water, however, must be permitted by the NMED Ground Water Quality Bureau (NMED-GWQB) under the regulations set forth in NMAC 20.6.2. This requirement applies to systems that discharge >2000gpd only. The vast majority of dischargers in New Mexico discharge to ground water and therefore hold these types of permits, which are known as discharge plans (DPs).

Permits issued by the NMED-GWQB are somewhat different than NPDES permits. While NPDES permits always set specific effluent limitations, DPs may require effluent limits or may rely on ground water monitoring. Sometimes DPs are issued that allow for the discharge of effluent containing nitrate over the NM water quality standards if the discharge is applied to a crop at no more

than 125% of the agronomic uptake rate. (The intention of this type of DP is that the nitrogen is used by the crop and therefore does not contaminate the ground water). The depth and direction of ground water and the potential for public contact with the discharge greatly affect the requirements set forth in ground water DPs.

DPs are issued for five years and, like NPDES permits, the responsibility for renewal of the permit lies with the permit holder. Samples taken for monitoring purposes must be analyzed in accordance with methodologies specified in NMAC, Title 20. Large facilities typically analyze their own monitoring samples but virtually all small and medium sized dischargers utilize contract laboratories. Monitoring reports are generally required quarterly and must be filed with NMED-GWQB. If the DP allows nitrate discharges in excess of NM water quality standards for the purposes of crop irrigation, the total nitrogen application (in lbs./acre) must be reported on a Land Application Data Sheet (LADS). An example LADS is shown in Figure 16.1.

### **NMAC, TITLE 20, CHAPTER 6, PART 4**

The regulations that pertain to operator certification and facility classification are located in NMAC 20.6.4, (commonly called the certification regulations). This regulation makes it illegal for anyone to operate a wastewater treatment facility in NM without the proper license. The licensing requirements for facilities are determined from a table that specifies the population served and the technology employed. Operator licenses are granted to individuals after three requirements have been met; (1) a designated number of years experience operating wastewater facilities must be demonstrated (one year minimum), (2) education requirements must be met for each level sought (minimum of 10 training credits), (3) a written examination at the appropriate level must be passed with a score of at least 70%.

The Facility Operation Section (FOS) of the NMED-SWQB administers the utility operator certification program. The FOS is responsible for exam application review and



DP#: \_\_\_\_\_ FACILITY NAME: \_\_\_\_\_

FIELD: \_\_\_\_\_ ACRES: \_\_\_\_\_ REPORT PERIOD - FROM: \_\_\_\_\_ TO: \_\_\_\_\_

CROP 1: \_\_\_\_\_ YIELD: \_\_\_\_\_

CROP 2: \_\_\_\_\_ YIELD: \_\_\_\_\_ TOTAL NITROGEN UPTAKE OF CROP(S): \_\_\_\_\_ lbs/ac

CROP 3: \_\_\_\_\_ YIELD: \_\_\_\_\_

**Effluent**

DATE/MONTH OF APPLICATION	CROP IN AT TIME OF APPLICATION	A VOLUME OF EFFLUENT APPLIED <sup>1</sup> gal	B LAB RESULTS <sup>2</sup> (TKN + NO <sub>3</sub> -N) mg/l	C NITROGEN CONCENTRATION (B x 8.3452 x 10 <sup>-6</sup> ) lbs/gal	D TOTAL NITROGEN (A x C) lbs N	E NITROGEN (D/acre) lbs N/acre	APPLICATION METHOD Flood, Sprinkler, etc.
January							
February							
March							
April							
May							
June							
July							
August							
September							
October							
November							
December							
Total Nitrogen Applied from Effluent (lbs/ac)							

**Figure 16.1 - Land Application Data Sheet ( LADS)**

approval, exam development and administration, certification reciprocity with other states as well as enforcement of the certification regulations. The FOS also provides training at various events throughout the state and through contracts with training providers.

**STANDARDS FOR THE USE OR DISPOSAL OF SEWAGE SLUDGE**

Federal regulations for the use or disposal of sewage sludge were promulgated in 1993 under 40 CFR Part 503. These regulations replaced the original sludge regulations found under 40 CFR Part 257. The 503 sludge regulations were developed with considerable input from the public and the wastewater treatment industry. 503 applies to virtually any primary and secondary sludge and scum produced as a result of wastewater treatment and even covers some disposal practices for domestic septage. The regulation specifies two types of activity; (1) beneficial use and (2) disposal. The beneficial use practices regulated by 503 include:

- Land Application, either in bulk or in bags to public contact sites.
- Land Application, in bulk to non-public contact sites.

The disposal practices regulated by 503 include:

- Surface Disposal
- Incineration

Placing sludge in a municipal landfill is an acceptable disposal practice, however, it is covered under NM Solid Water Bureau regulations, not 40 CFR 503.

Each of the beneficial use and disposal practices allowed by 503 sets requirements for:

- Reduction of pathogens
- Reduction of the vector attraction of the sludge
- Pollutant limits for heavy metals and PCBs
- Restrictions for land application and surface disposal sites, and
- Management practices for land application and surface disposal activities.

503 also sets a limit on how long sludge can be stored at a wastewater treatment plant before it must be beneficially re-used or disposed. If sludge remains in storage for more than two (2) years, the site is considered a surface disposal site and all applicable aspects of the 503 regulations must be met, unless the owner/operator can demonstrate the storage constitutes treatment based on operational practices.

## **OCCUPATIONAL SAFETY AND HEALTH ADMINISTRATION (OSHA) REGULATIONS**

The Occupational Safety and Health Administration (OSHA) is a federal governmental agency under the U.S. Department of Labor. Its purpose is to enforce the laws concerning worker and work place safety.

New Mexico has an approved state OSHA program that works in conjunction with the federal OSHA program. Enforcement is done by the state. OSHA administers laws that cover the entire spectrum of worker health and safety. Wastewater operators should be concerned with the following areas that are regulated by OSHA (at minimum):

- Personal protective equipment (steel toe boots, gloves, face shield, goggles)
- Confined space entry
- Equipment lock-out/ tag-out
- Hazard communication standard (material safety data sheets (MSDS))
- Excavation Safety
- Blood-borne pathogen standard

Most OSHA laws require that employers establish workplace procedures to protect workers in the manner described by the law. For instance, the hazard communication standard requires that employers provide employees information concerning hazardous chemicals used in the workplace in the form of Material Data Safety Sheets (MSDS).

### ***References***

Federal Clean Water Act  
NMAC, Title 20, Chapter 6, Part 2  
NMAC, Title 20, Chapter 6, Part 4  
40 Code of Federal Regulations, Part 503  
OSHA Confined Space Entry Standard  
OSHA Lock Out/ Tag Out Standard  
OSHA Hazard Communications Standard  
OSHA Personal Protective Equipment Standard  
OSHA Blood-borne Pathogen Standard



# APPENDIX A: WASTEWATER MATH

---

## COMMON EQUIVALENTS USED TO SOLVE WASTEWATER MATH PROBLEMS

### LINEAR AND AREA MEASUREMENT

2.54 centimeters per inch  
39.37 inches per meter  
5,280 feet per mile  
1.61 kilometers per mile  
144 square inches per square foot  
43,560 square feet per acre

### VOLUME

7.481 gallons per cubic foot  
27 cubic feet per cubic yard  
3.785 liters per gallon  
1000 milliliters per liter  
43,560 cubic feet per acre-foot

### WEIGHT

16 ounces per pound  
453.6 grams per pound  
1000 grams per kilogram  
2.2 kilograms per pound  
7000 grains per pound

### DENSITY AND PRESSURE

Water weighs 8.34 pounds per gallon (at 60° F)  
1 liter of water weighs 1 kilogram (at 60° F)  
The specific gravity of water is 1.0000 (at 60° F)  
2.31 Feet of water generates 1.0 pound per square inch  
of pressure  
1.0 Foot of water generates 0.433 pounds per square inch  
of pressure

### TIME

60 seconds per minute  
60 minutes per hour  
24 hours per day  
1440 minutes per day  
30 days per month (average)

### FLOW

448.8 gallons per minute per 1 cubic foot per second  
646,300 gallons per day per 1 cubic foot per second  
694.4 gallons per minute per 1 MGD  
1.545 cubic feet per second per 1 MGD  
1,000,000 gallons per day per 1 MGD  
0.646 MGD per 1 cubic foot per second

### DOSAGE

1 milligram per liter per 1 part per million  
17.1 parts per million per 1 grain per gallon  
8.34 pounds of solids in 1,000,000 gallons of water per 1  
part per million

### POWER

550 foot pounds per second per 1 horsepower  
33,000 foot pounds per minute per 1 horsepower  
746 watts per 1 horsepower  
1.34 horsepower per 1 kilowatt

### TYPICAL VALUES FOR WASTEWATER SYSTEMS

0.2 pounds of Total Suspended Solids per person per day  
0.17 pounds of Biochemical Oxygen Demand per person  
per day  
100 gallons of sewage per person per day  
3.5 people per residence

# APPENDIX B: WASTEWATER MATH

## FORMULAS USED TO SOLVE WASTEWATER MATH PROBLEMS

### AREA OF A SQUARE OR RECTANGLE

$$A = L \times W$$

Where: A = area in square feet

L = length in feet

W = width in feet

### AREA OF A CIRCLE

$$A = \pi \times r^2$$

Where: A = area of circle in sq ft

$$\pi = 3.14$$

r = radius of circle in ft

OR

$$A = d^2 \times .7854$$

Where: A = area of circle in sq ft

d = diameter of circle in ft



### CIRCUMFERENCE OF A CIRCLE

$$C = \pi \times d$$

Where: C = circumference of circle in ft

$$\pi = 3.14$$

d = diameter of circle in ft

### VOLUME OF A SQUARE OR RECTANGULAR TANK

$$V = L \times W \times H$$

Where: V = volume in cubic ft

L = length in ft

W = width in ft

H = height in ft

### VOLUME OF CYLINDRICAL TANKS AND PIPES

$$V = A \times H$$

Where: V = volume in cubic ft

A = area of circle in square ft

H = height of tank or length of pipe in ft

### VOLUME OF A CONE

$$V = \frac{A \times H}{3}$$

Where: V = volume of cone in cubic feet

A = area of circle in square feet

H = height of cone in feet

### FLOW IN OPEN CHANNELS AND FULL PIPES

$$Q = A \times V$$

Where: Q = flow in cubic feet per second

A = cross sectional area in square feet

V = velocity of water in feet per second

### DETENTION TIME

$$DT = \frac{V}{Q}$$

Where: DT = detention time in minutes

V = volume of liquid in tank in gallons

Q = flow through tank in gallons per minute

### REMOVAL EFFICIENCY

$$Eff = \frac{In - Out}{In} \times 100$$

Where: Eff = removal efficiency as a %

In = concentration entering unit in mg/L

Out = concentration exiting unit in mg/L

### LOADING

$$lbs./day = mg/l \times MGD \times 8.34$$

Where: lbs./day = loading rate in pounds per day

mg/L = concentration in mg/L

MGD = flow in MGD

### CHEMICAL FEED

$$lbs/day \text{ fed} = \frac{lbs./day \text{ chemical}}{\text{chemical strength}}$$

Where: lbs/day fed = total amount fed in lbs per day

lbs/day chemical = loading rate lbs per day

chemical strength = chemical strength as a decimal

### SURFACE LOADING RATE IN CLARIFIERS

$$SLR = \frac{Q}{A}$$

Where: SLR = surface loading rate in gpd per sq ft

Q = flow in gallons per day

A = surface area of clarifier

### ORGANIC LOADING IN PONDS

$$OL = \frac{BOD \text{ Loading}}{\text{Acres}}$$

Where: OL = organic loading in lbs per day per acre

BOD Loading = BOD loading in lbs per day

Acres = total acreage of pond(s)

**HYDRAULIC LOADING FOR TRICKLING FILTERS**

$$HL = \frac{A}{Q}$$

Where: HL = hydraulic loading in gpd / square foot  
 A = surface area of TF in square feet  
 Q = flow to TF in gallons per day

**POWER WATER HORSEPOWER**

$$WHP = \frac{TDH \times Q \times 8.34}{33,000}$$

Where: WHP = water horsepower  
 TDH = total dynamic head in feet  
 Q = flow in gpm

**ORGANIC LOADING FOR TRICKLING FILTERS**

$$OL = \frac{\text{BOD Loading}}{\text{Media Volume}}$$

Where: OL = organic loading in lbs./day / 1000 cuft  
 BOD Loading = lbs./day BOD applied to TF  
 Media Volume = volume in 1000 cubic feet

**POWER BRAKE HORSEPOWER**

$$BHP = \frac{WHP}{\text{Pump Efficiency}}$$

Where: BHP = brake horsepower  
 WHP = water horsepower  
 Pump Efficiency = expressed as a decimal

**TEMPERATURE****FAHRENHEIT TO CELSIUS AND CELSIUS TO FAHRENHEIT**

$$^{\circ}F = (^{\circ}C \times 1.8) + 32$$

$$^{\circ}C = (^{\circ}F - 32) \times 0.56$$

Where:  $^{\circ}F$  = temperature in Fahrenheit  
 $^{\circ}C$  = temperature in Celsius

**POWER MOTOR HORSEPOWER**

$$MHP = \frac{BHP}{\text{Motor Efficiency}}$$

Where: MHP = motor horsepower  
 BHP = brake horsepower  
 Motor Efficiency = expressed as a decimal

**FILTRATION RATE FOR SAND FILTERS**

$$FR = \frac{A}{Q}$$

Where: FR = filtration rate in gpm / square foot  
 A = surface area of filter in square feet  
 Q = flow through filter in gpm

**POWER KILOWATTS REQUIRED**

$$kW = MHP \times 0.746$$

Where: kW = kilowatt required  
 MHP = motor horsepower

**F:M RATIO FOR ACTIVATED SLUDGE SYSTEMS**

$$F:M = \frac{\text{BOD Loading to Aeration Basin}}{\text{Lbs. of MLVSS in Aeration Basin}}$$

Where: F:M = food to microorganism ratio of system  
 BOD Loading to Aeration Basin = BOD mg/L x MGD x 8.34  
 Lbs. of MLVSS in Aeration Basin = MLVSS mg/L x MG x 8.34

**MEAN CELL RESIDENCE TIME FOR ACTIVATED SLUDGE SYSTEMS**

$$MCRT = \frac{\text{Total lbs. of Suspended Solids In Aeration Basin}}{(\text{Lbs./day of WAS Solids Removed}) + (\text{lbs./day of Effluent Solids})}$$

Where: MCRT = Mean Cell Residence Time for System in Days  
 Total Lbs. of Suspended Solids in System = MLSS mg/L x MG x 8.34  
 Lbs./day of WAS Solids Removed = WAS TSS mg/L x MGD x 8.34  
 Lbs./day of Effluent Solids = Eff TSS mg/L x MGD x 8.34

**SLUDGE VOLUME INDEX FOR ACTIVATED SLUDGE SYSTEMS**

$$SVI = \frac{\text{mL/L} \times 1000}{\text{MLSS}}$$

Where: SVI = sludge volume index in milliliters per gram (mL/gm)  
 mL/L = 30 minute settleometer reading in milliliters per liter  
 MLSS = mixed liquor suspended solids concentration in mg/L

# APPENDIX C: FECAL COLIFORM - HOW TO CALCULATE GEOMETRIC MEAN

Determine the optimum number of colonies per plate based on the series of dilutions. The acceptable range is usually 20 to 60 colonies. If it is too dense to count refer to the “Most Commonly Asked Questions” section of Chapter 15 - Sampling and Reporting, for directions on reporting TNTC.

**Table A3.1 - Example Sampling Schedule**

Monday	20 colonies (20 colonies/100 mL x 100 = 20 colonies/100 mL)
Tuesday	60 colonies (60 colonies/100 mL x 100 = 60 colonies/100 mL)
Wednesday	45 colonies (45 colonies/100 mL x 100 = 45 colonies/100 mL)
Thursday	300 colonies (30 colonies/10 mL x 100 = 300 colonies/100mL)
Friday	550 colonies (55 colonies/10 mL x 100 = 550 colonies/100 mL)
Saturday	42 colonies (42 colonies/100 mL x 100 = 42 colonies/100 mL)
Sunday	27 colonies (27 colonies/100 mL x 100 = 27 colonies/100 mL)

There are two methods by which to calculate the geometric mean (GM). Method One is the product of all the values ( $n_1 \times n_2 \times n_3 \dots$ ) followed by taking the  $n$ th root of the multiplication factor, and Method Two is to average the sum of the logs ( $\log n_1 + \log n_2 + \log n_3 \dots$ ) followed by the antilog of the average.

The example in Table A3.1 is based on a 7x/week sampling schedule, using the optimum range for colony plate count (20 - 60 colonies) and sample filtration volumes of 100 mL, 10 mL, 1.0 mL, and 0.1 mL (the smallest filtration volume being of 0.1 mL):

## USING THE METHOD ONE FORMULA

$$GM = \text{“nth” root of } n_1 \times n_2 \times n_3 \dots$$

The 7-day fecal coliform geometric mean would be calculated by multiplying the seven values  $20 \times 60 \times 45 \times 300 \times 550 \times 42 \times 27$  and taking the seventh root of the multiplication product which yields a geometric mean of 72.

## USING THE METHOD TWO FORMULA

$$X = \frac{\text{Sum of the Log for Sample Measurements}}{\# \text{ samples}}$$

Then take the anti-log of X to obtain the GM.

The 7-day fecal coliform geometric mean would be calculated by adding the sum of the logs for each value ( $\log 20 = 1.30103 + \log 60 = 1.77815 + \log 45 = 1.65321 + \log 300 = 2.047712 + \log 550 = 2.074036 + \log 42 = 1.62325 + \log 27 = 1.43136$ ), dividing the summation of 13.00448 by 7 = 1.85778, followed by the anti-log of the result which also yields a geometric mean of 72.

## HOW TO AVERAGE “<” DAILY MAX OR 7-DAY AVERAGES INTO THE 30-DAY AVERAGE

For samples that have a value of “0 colonies” on a plate count, the value must be reported as less than (calculated value) / 100 mL, based upon the largest single volume filtered. For example, if 10 mL, 1.0 mL and 0.1 mL are filtered and all plates show zero counts, select the largest volume, and apply the general formula for determining fecal coliform counts at various dilutions and report the count as < (less than) value.

$$\frac{1}{10} \times 100 = <10 \text{ fecal coliforms / 100 mL}$$

If the geometric mean for a reporting period (i.e., the 7-day average or 30-day average) has a sample with a zero count, use the above formula to obtain a “< fecal coliform count”, and average that number (i.e. 10 from the above example) with the other samples taken.



# APPENDIX D: DEFINITIONS AND CALCULATIONS FOR DMRS

---

## DEFINITIONS

The following are definitions of some terms used for reporting on the Discharge Monitoring Report (DMR).

### ANNUAL AVERAGE FLOW

The arithmetic average of all daily flow determinations taken within the preceding 12 consecutive calendar months. The annual average flow determination shall consist of daily flow volume determinations made by a totalizing meter, charted on a chart recorder and limited to major domestic wastewater discharge facilities with a 1 million gallons per day or greater permitted flow.

### DAILY AVERAGE FLOW

The arithmetic average of all determinations of the daily discharge within a period of one calendar month. The daily average flow determination shall consist of determinations made on at least four separate days. If instantaneous measurements are used to determine the daily discharge, the determination shall be the arithmetic average of all instantaneous measurements taken during that month. Daily average flow determination for intermittent discharges shall consist of a minimum of three flow determinations on days of discharge.

### DAILY MAXIMUM FLOW

The highest total flow for any 24-hour period in a calendar month.

### INSTANTANEOUS FLOW

The measured flow during the minimum time required to interpret the flow measuring device.

### 2-HOUR PEAK FLOW

Applies to domestic wastewater treatment plants: The maximum flow sustained for a two-hour period during the period of daily discharge. Multiple measurements of instantaneous maximum flow within a two hour period may be compared to the permitted 2-hour peak flow.

### MAXIMUM 2-HOUR PEAK FLOW

Applies to domestic wastewater treatment plants: The highest 2-hour peak flow for any 24-hour period in a calendar month.

### DAILY AVERAGE CONCENTRATION

The arithmetic average of all effluent samples, composite or grab as required by the permit, within a period of one calendar month, consisting of at least four separate representative measurements. When four samples are not available in a calendar month, the arithmetic average of the four most recent measurements or the arithmetic average

(weighted by flow) of all values taken during the month shall be used as the daily average concentration.

### 7-DAY AVERAGE CONCENTRATION

The arithmetic average of all effluent samples, composite or grab as required by the permit, within a period of one calendar week, Sunday through Saturday.

### DAILY MAXIMUM CONCENTRATION

The maximum concentration measured on a single day, by composite sample unless otherwise specified in the permit, within a period of one calendar month.

### FECAL COLIFORM BACTERIA CONCENTRATION

The number of colonies of fecal coliform bacteria per 100 milliliters of effluent. The fecal coliform bacteria daily average is a geometric mean of the values for the effluent samples collected in a calendar month. The geometric mean shall be determined by calculating the  $n^{\text{th}}$  root of the product of all measurements made in a particular period of time.

For example in a month's time, where  $n$  equals the number of measurements made; or, computed as the antilogarithm of the arithmetic average of the logarithms of each measurement made. For any measurement of fecal coliform bacteria equaling zero, a substituted value of one shall be made for input into either computation method.

### COMPOSITE SAMPLE

For domestic wastewater, a sample made up of a minimum of three effluent portions collected in a continuous 24-hour period or during the period of daily discharge if less than 24 hours, and combined in volumes proportional to flow, and collected no closer than two hours apart. For industrial wastewater, a composite sample is a sample made up of a minimum of three effluent portions collected in a continuous 24-hour period or during the period of daily discharge if less than 24 hours, and combined in volumes proportional to flow, and collected no closer than one hour apart.

### GRAB SAMPLE

An individual sample collected in less than 15 minutes at peak flows.

## EXAMPLE CALCULATIONS & REPORTING FOR CONCENTRATION, LOADING, FLOW, CL2 RESIDUAL & PH

The example calculations and reporting instructions described in this section are illustrated using data in Table D.1 - Example Daily Operations Log for March.

Table D.1 - Example Daily Operations Log for March

Day of Week	Date	Flow (MGD)	BOD (mg/L)	TSS (mg/L)	pH (u.u.)	CL <sub>2</sub> (mg/L)	BOD <sub>5</sub> (lbs/dy)	TSS (lbs/dy)
Sunday	3/1	0.17						
Monday	3/2	0.20				2.00		
Tuesday	3/3	0.19	22.00	30.00	7.50	1.40	34.86	47.54
Wednesday	3/4	0.17				1.30		
Thursday	3/5	0.14				1.00		
Friday	3/6	0.15				1.00		
Saturday	3/7	0.13						
Sunday	3/8	0.17						
Monday	3/9	0.23				1.40		
Tuesday	3/10	0.20	29.00	23.00	7.00	2.10	48.37	38.36
Wednesday	3/11	0.34				1.10		
Thursday	3/12	0.30				1.00		
Friday	3/13	0.20				1.20		
Saturday	3/14	0.14						
Sunday	3/15	0.15						
Monday	3/16	0.20				0.00		
Tuesday	3/17	0.18	18.00	16.00	7.20	1.30	27.02	24.02
Wednesday	3/18	0.17				1.10		
Thursday	3/19	0.21				1.40		
Friday	3/20	0.22				1.40		
Saturday	3/21	0.13						
Sunday	3/22	0.14						
Monday	3/23	0.21				1.00		
Tuesday	3/24	0.19	10.00		6.00	1.30	15.85	
Wednesday	3/25	0.18				1.70		
Thursday	3/26	0.20				1.30		
Friday	3/27	0.17				2.10		
Saturday	3/28	0.15						
Sunday	3/29	0.13						
Monday	3/30	0.19				2.20		
Tuesday	3/31	0.14				1.40		
Total	31	5.69	79.00	69.00	-	-	126.10	109.92
Average	-	0.183	19.75	23.12	N/A	N/A	31.53	36.64
Maximum	-	0.34	29.00	30.00	7.50	2.20	48.37	47.54
Minimum	-	0.13	10.00	16.00	6.00	0.00	15.85	24.02

**REPORTING OF CONCENTRATION**

The example Daily Operations Log shows that four individual BOD5 grab samples were obtained during the month as follows:

- March 3 - 22.00 mg/L
- March 10 - 29.00 mg/L
- March 17 - 18.00 mg/L
- March 24 - 10.00 mg/L

The daily average concentration is calculated by adding the four values obtained and dividing by the number of samples taken during the month. The calculated BOD5 daily average is 19.75 mg/L. (See Figure D.1.)

$$\frac{(22.00 + 29.00 + 18.00 + 10.00)}{4} = 19.75 \text{ mg/L Daily Average BOD}_5$$

**Figure D.1**

The highest BOD5 concentration was obtained on March 10. This value is reported as the maximum BOD5 individual grab for the reporting period.

**REPORTING OF LOADINGS**

Some parameters in the permit are limited in terms of pounds per day (lbs/day). Although all of these parameters are measured initially in milligrams per liter (mg/L), conversion to lbs/day can be achieved by using the following formula. **Always be sure to use the flow measurement determined on the day when sampling was done.** (See Figure D.2.)

**Flow on day of sampling (MGD) x concentration (mg/L) x 8.34 (lbs/gal) = Loading (lbs/day)**

**Figure D.2**

**Table D.2**

March 3	-	(.19 MGD) (22.00 mg/L) (8.34 lbs/gal)	=	34.86 lbs/day
March 10	-	(.20 MGD) (29.00 mg/L) (8.34 lbs/gal)	=	48.37 lbs/day
March 17	-	(.18 MGD) (18.00 mg/L) (8.34 lbs/gal)	=	27.02 lbs/day
March 24	-	(.19 MGD) (10.00 mg/L) (8.34 lbs/gal)	=	15.85 lbs/day

Using the four BOD5 concentrations and the flow measurements obtained on the days of sampling, the individual daily loadings are calculated as in Table D.2.

The daily average loading (lbs/day) is calculated by adding the individual daily loading values together and dividing by the number of samples taken during the month. The calculated BOD5 daily average loading is 31.53 lbs/day. (See Figure D.3).

$$\frac{(34.86 + 48.37 + 27.02 + 15.85)}{4} = 31.53 \text{ lbs/day Daily Average BOD}_5$$

**Figure D.3**

**FLOW-WEIGHTED AVERAGES**

When four samples are not available in a calendar month, the daily average concentration should be calculated using the four most recent measurements or the arithmetic average (weighted by flow) of all values taken during the month. The example Daily Operations Log shows that TSS grab samples were taken only three times during the month. The values obtained and the flows on the days of sampling are as shown in Table D.3.

**Table D.3**

	TSS (mg/L)	Flow on day of sampling (MGD)
March 3	30.00	.19
March 10	23.00	.20
March 17	16.00	.18
	Total flow on sample days	.57

To calculate the flow-weighted concentration for each sample, the equation in Figure A4.4 must be used. The flow-weighted average concentration is then determined by adding the flow-weighted concentrations for the individual samples together. (See Figure D.5 and Table D.4.)

$$\text{Concentration (mg/L)} \times \frac{\text{Flow on day of sampling (MGD)}}{\text{Total flow on days of sampling (MGD)}} = \text{Flow-weighted Concentration}$$

**Figure D.4**

$$\text{Sum of Flow-weighted Concentrations} = \text{Flow-weighted Daily Average Concentration}$$

**Figure A4.5**

**Table D.4**

March 3	30.00 mg/L x .19/.57	=	10.00
March 10	23.00 mg/L x .20/.57	=	8.07
March 17	16.00 mg/L x .18/.57	=	5.05
Flow-weighted Daily Average TSS Concentration		=	23.12 mg/L

To calculate the daily average flow-weighted loading, the equation illustrated in Figure A4.6 must be used.

$$\text{Daily average flow-weighted concentration} \times \text{Average of flows on sampling days} \times 8.34 \text{ lbs/gal} = \text{Flow-weighted Daily Average Loading (lbs/day)}$$

$$23.12 \text{ mg/L} \times \frac{.19 + .20 + .18}{3} \times 8.34 = 36.64 \text{ lbs/day Flow-weighted Daily Average TSS Loading}$$

**Figure D.6**

## pH

A review of the example Daily Operations Log indicates four pH values were obtained during the reporting period ranging from a minimum value of 6.80 s.u. on March 24 to a maximum value of 7.50 s.u. on March 3. The highest pH value obtained on March 3 is reported as the maximum pH for the reporting period. The lowest pH value obtained on March 24 is reported as the minimum pH for the reporting period. (*Note that pH is not subject to averaging.*)

## CL2 RESIDUAL

A review of the example Daily Operations Log shows Cl2 residual values ranging from a minimum value of 0.00 mg/L on March 16 to a maximum value of 2.20 mg/L on March 30 were obtained during the reporting period. The highest Cl2 value obtained on March 30 is reported as the maximum Cl2 residual for the reporting period. The lowest Cl2 value obtained on March 16 is reported as the minimum Cl2 residual for the reporting period. (*Note that chlorine residual is not subject to averaging.*)

## FLOW

### Daily Average Flow and Daily Maximum Flow

The average daily flow is calculated by adding the individual daily flow measurements together and dividing by the number of days on which flow measurements were taken during the month. The average daily flow calculated from the example Daily Operations Log is 0.183 MGD. The daily maximum flow is the highest daily flow value obtained during the reporting period. On the example Daily Operations Log, the daily maximum flow value is 0.34 MGD, which occurred on March 11.

### Annual Average Flow

The annual average flow is the arithmetic average of all daily flow determinations taken during the previous 12-month period. It is calculated by adding the individual daily flow measurements together and dividing by the number of measurements taken during the previous 365 days. For example, if the total flow recorded during a 12-month period is 600 MG and during that period of time flow measurements were obtained once per day, the annual average would be calculated as in Figure D.7.

$$600 \text{ MG}/365 \text{ Days} = 1.64 \text{ MGD Annual Average Flow}$$

**Figure D.7**



For new facilities, the first annual average should be calculated based on the number of measurements taken during the first full month of operation. The second annual average should be calculated based on the number of measurements taken during the first and second months of operation. The third annual average should be calculated based on the number of measurements taken during the first, second and third months of operation, etc. After twelve months of operation, all annual average flows should be calculated using the sum of the individual flow measurements divided by the number of measurements taken during the previous 365 days.

For example, during the first full month of operation, if the total flow recorded is 45 MG and 30 flow measurements were taken (one each day), the annual average flow would be calculated by dividing the total flow by the number of measurements taken during the month: **45 MG/30 Measurements = 1.5 MGD Annual Average Flow.** During the next 30 days, if the total flow recorded is 75 MG and 31 measurements were taken (one each day), the annual average flow would be calculated by dividing the total flow for the first 61 days by the number of measurements taken during that period: **45 MG + 75 MG/61 Measurements = 1.967 MGD Annual Average Flow.** During the third month of operation, if the total flow recorded is 65 MG and 31 measurements were taken (one each day), the annual average would be calculated by dividing the total flows for the first 92 days by the number of measurements taken during that period: **45 MG + 75 MG + 65 MG / 92 Measurements = 2.01 MGD Annual Average Flow.**

### 2-hour Peak Flow

The 2-hour peak flow is the maximum flow sustained for a two-hour period during the period of daily discharge. The maximum 2-hour peak flow which is reported on the Discharge Monitoring Report should be the highest 2-hour peak flow for any 24-hour period in a calendar month. ater Permits and Resource Management Division.

## CALCULATING FECAL COLIFORM GEOMETRIC MEAN

Fecal coliform bacteria concentration is the number of colonies of fecal coliform bacteria per 100 milliliters effluent. Fecal coliform bacteria daily average is the geometric mean of the fecal coliform samples collected in

a calendar month. The following instructions show two ways to calculate the geometric mean.

### NTH ROOT

The geometric mean can be calculated as the *n*th root of the product of *n* data points. In this case, *n* is the number of fecal coliform bacteria sample results.

$$\text{Geometric Mean} = n\sqrt{X_1 X_2 X_3 X_4 X_5 \dots X_n}$$

For example, if five fecal coliform bacteria samples are taken and the samples results are 99, 126, 90, 420, and 2200 colonies/mL, the calculated geometric mean is 253.

$$(99)(126)(90)(420)(22) = 1.037 \times 10^{12}$$

$$\sqrt[5]{1.037 \times 10^{12}} = 253$$

### ANTILOG

The geometric mean can also be calculated by taking the antilog of the arithmetic average of the logarithms of the sample results. The following instructions describe how this can be done using the data provided in the chart as an example. (See Table D.5.)

1. Calculate the logarithm for each sample result.  
For example: The second sample result in the chart is 120. Enter 120 into the calculator and press the log function. The result is 2.079. This is the log of 120. \*
2. Calculate the arithmetic average of the logarithms.  
To do this, add all of the logarithm values together and divide the sum by the number of logarithm values. In the example in the chart, the sum of the logs is 13.703. Since there are 7 log values, divide 13.703 by seven to determine the average of the logs. The result is 1.9576. \*\*

Table D.4

Colonies per 100 mL (sample results)	Log of Colonies per 100 mL
10	1
120	2.079*
601	2.779
48	1.681
130	2.114
11	1.041
1020	3.009
Arithmetic Average	13.703 ÷ 7 = 1.9576 **
Geometric Mean	Antilog of 1.9576 = 91 ***

- Take the antilog of the arithmetic average of the logarithms. This will be the geometric mean. Using the example in the chart, enter 1.9576 into the calculator and press the antilog function. The result is 91. This is the geometric mean for the sample results. \*\*\*

determine reportable values based on the MAL permit provision, using Mercury as an illustration.

$$\text{MAL for Mercury} = 0.0002 \text{ mg/L (0.2 } \mu\text{g/l)}$$

Example 1: Some measured values above the MAL and some below the MAL (see Table D.5)

Values to be Reported on the DMR:

- Daily Maximum Concentration: 0.00034 mg/L
- Daily Average Concentration: 0.00015 mg/L
- Daily Average Loading: 0.00144 lbs/day

Example 2: All measured values below the MAL (see Table D.6)

Values to be Reported on the DMR

- Daily Maximum Concentration: <0.0002 mg/L
- Daily Average Concentration: 0 mg/L
- Daily Average Loading: 0 lbs/day

### USING THE MAL PROVISION TO DETERMINE REPORTABLE RESULTS

For some parameters (toxic organic and inorganic constituents), the permit will contain a provision in the Other Requirements section stating that compliance/noncompliance determinations will be based on the minimum analytical level (MAL) for the parameter, and effluent concentrations measured as less than the MAL are deemed to be compliant with the permit limits. This permit provision further states that when an analysis of an effluent sample for the parameter results in a measurement of less than the MAL that parameter shall be reported as “<(MAL value)” and this shall be interpreted as a value of zero (0) for compliance purposes. This means, in these instances, to record the concentration for the sample as < (MAL value) for the purposes of determining daily maximum concentration and use a zero for that measurement when calculating the daily average concentration and the daily average loading. The following examples show how to

**Table D.5**

Sample	Lab Result for Mercury (mg/L)	Concentration (mg/L) to be used for calculating average & loading	Flow on day of sample collection (MGD)	Loading (lbs/day)
Sample 1	0.00014 (<0.0002)	0.0	1.022	0.0
Sample 2	0.00028	0.00028	1.039	0.00242
Sample 3	0.00034	0.00034	1.186	0.00336
Sample 4	0.00012 (<0.0002)	0.0	0.974	0.0
Average	—	0.00015	—	0.00144

**Table D.6**

Sample	Lab Result for Mercury (mg/L)	Concentration (mg/L) to be used for calculating average & loading	Flow on day of sample collection (MGD)	Loading (lbs/day)
Sample 1	0.00014 (<0.0002)	0.0	1.183	0.0
Sample 2	0.00011 (<0.0002)	0.0	0.966	0.0
Sample 3	0.00018 (<0.0002)	0.0	1.205	0.0
Sample 4	0.00015 (<0.0002)	0.0	1.078	0.0
Average	---	0.0	—	0.0

Note: When an analysis of an effluent sample for a parameter covered by the MAL permit provision indicates no detectable levels and the test method detection level is not as sensitive as the specified MAL, then the level of detection achieved must be used for that sample result in determining reportable maximum and average values. A zero (0) may not be used.

**NO DETECTION FOR NON-MAL PARAMETERS**

When an analysis of an effluent sample indicates no detectable levels for a parameter not covered by the MAL permit provision, the level of detection achieved must be used for that sample result in determining reportable maximum and average values. A zero (0) may not be used.

**CALCULATING SEWAGE SLUDGE DRY METRIC TONS**

On the SLDP DMR for sewage sludge production and use, the permittee must report the amount of sewage sludge produced and the amount of sewage sludge disposed or beneficially reused in dry metric tons. The following calculations show how to convert gallons or cubic yards of sewage sludge into dry metric tons.

**CONVERTING GALLONS TO DRY METRIC TONS**

To convert gallons of sewage sludge to dry metric tons, the equations in Figure D.7 can be used.

Where:

X = Gallons of sewage sludge

$$\frac{(22500)(8.34)(0.05)}{(2.2046)(1000)} = 4.26 \text{ dry metric tons}$$

**Figure D.8**

$$\frac{X \text{ gal}}{1} \times \frac{8.34 \text{ lbs}}{1 \text{ gal}} \times \frac{1 \text{ KG}}{2.2046 \text{ lbs}} \times \frac{1 \text{ MT}}{1000 \text{ KG}} \times \frac{\% \text{ Dry MT}}{1 \text{ MT}} = \text{Dry Metric Tons}$$

Short Conversion

$$\frac{(X)(8.34)(\%)}{(2.2046)(1000)}$$

Where:

X = Gallons of sewage sludge

**Figure D.7**

$$\frac{X \text{ yd}^3}{1} \times \frac{27 \text{ ft}^3}{1 \text{ yd}^3} \times \frac{Y \text{ lbs}}{1 \text{ ft}^3} \times \frac{1 \text{ KG}}{2.2046 \text{ lbs}} \times \frac{1 \text{ MT}}{1000 \text{ KG}} \times \frac{\% \text{ Dry MT}}{1 \text{ MT}} = \text{Dry Metric Tons}$$

Short Conversion:

$$\frac{(X)(27)(Y)(\%)}{(2.2046)(1000)}$$

**Figure D.9**

% = Percent of solids in the sewage sludge

The other values in the equation are conversion factors.

For example, if the permittee disposes of 22,500 gallons of sewage sludge that has a solids content of 5%, the amount disposed is 4.26 dry metric tons. (See Figure D.8)

**CONVERTING CUBIC YARDS TO DRY METRIC TONS**

To convert cubic yards of sewage sludge to dry metric tons, the equations in Figure D.9 can be used.

Where:

X = Cubic yards of sewage sludge

Y = Unit weight of sewage sludge in pounds per cu ft

% = Percent of solids in the sewage sludge

$$\frac{(100)(27)(75)(0.25)}{(2.2046)(1000)} = 22.96 \text{ dry metric tons}$$

**Figure D.10**

The other values in the equation are conversion factors.

For example, if the permittee disposes of 100 cubic yards of sewage sludge with a solids content of 25% and a unit weight of 75 pounds per cubic foot, the amount disposed is 22.96 dry metric tons. (See Figure D.10)

## APPENDIX E: GLOSSARY OF WASTEWATER TERMS

---

### ABS

**Alkyl Benzene Sulfonate.** A type of surfactant, or surface active agent, present in synthetic detergents in the United States before 1965. ABS was especially troublesome because it caused foaming and related breakdown by biological treatment processes. ABS has been replaced in detergents by linear alkyl sulfonate (LAS) which is biodegradable.

### ABS

### ABSORPTION (ab-SORP-shun)

Taking in or soaking up of one substance into the body of another by molecular or chemical action (as tree roots absorb dissolved nutrients in the soil).

### ABSORPTION

### ACID

(1) A substance that tends to lose a proton. (2) A substance that dissolves in water with the formation of hydrogen ions. (3) A substance containing hydrogen which may be replaced by metals to form salts.

### ACID

### ACIDITY

The capacity of water or wastewater to neutralize bases. Acidity is expressed in milligrams per liter of equivalent calcium carbonate. Acidity is not the same as pH because water does not have to be strongly acidic (low pH) to have a high acidity. Acidity is a measure of how much base can be added to a liquid without causing a great change in pH.

### ACIDITY

### ACTIVATED SLUDGE (ACK-ta-VATE-ed slug)

Sludge particles produced in raw or settled wastewater (primary effluent) by the growth of organisms (including zoogeal bacteria) in aeration tanks in the presence of dissolved oxygen. The term "activated" comes from the fact that the particles are teeming with bacteria, fungi, and protozoa. Activated sludge is different from primary sludge in that the sludge particles contain many living organisms which can feed on the incoming wastewater.

### ACTIVATED SLUDGE

### ACTIVATED SLUDGE PROCESS (ACK-ta-VATE-ed slug)

A biological wastewater treatment process which speeds up the decomposition of wastes in the wastewater being treated. Activated sludge is added to wastewater and the mixture (mixed liquor) is aerated and agitated. After some time in the aeration tank, the activated sludge is allowed to settle out by sedimentation and is disposed of (wasted) or reused (returned to the aeration tank) as needed. The remaining wastewater then undergoes more treatment.

### ACTIVATED SLUDGE PROCESS

### ADSORPTION (add-SORP-shun)

The gathering of a gas, liquid, or dissolved substance on the surface or interface zone of another substance.

### ADSORPTION

### ADVANCED WASTE TREATMENT

Any process of water renovation that upgrades treated wastewater to meet specific reuse requirements. May include general cleanup of water or removal of specific parts of wastes insufficiently removed by conventional treatment processes. Typical processes include chemical treatment and pressure filtration. Also called TERTIARY TREATMENT.

### ADVANCED WASTE TREATMENT

### AERATION (air-A-shun)

The process of adding air. In wastewater treatment, air is added to freshen wastewater and to keep solids in suspension. With mixture of wastewater and activated sludge, adding air provides mixing and oxygen for the microorganisms treating the wastewater.

### AERATION

### AERATION LIQUOR (air-A-shun)

Mixed liquor. The contents of the aeration tank including living organisms and material carried into the tank by either untreated wastewater or primary effluent.

### AERATION LIQUOR

### AERATION TANK (air-A-shun)

The tank where raw or settled wastewater is mixed with return sludge and aerated. The same as aeration bay, aerator, or reactor.

### AERATION TANK



**AEROBES**

Bacteria that must have molecular (dissolved) oxygen (DO) to survive. Aerobes are aerobic bacteria.

**AEROBES****AEROBIC (AIR-O-bick)**

A condition in which "free" or dissolved oxygen is present in the aquatic environment.

**AEROBIC****AEROBIC BACTERIA (AIR-O-bick back-TEAR-e-ah)**

Bacteria which will live and reproduce only in an environment containing oxygen which is available for their respiration (breathing), namely atmospheric oxygen or oxygen dissolved in water. Oxygen combined chemically, such as in water molecules ( $H_2O$ ), cannot be used for respiration by aerobic bacteria.

**AEROBIC BACTERIA****AEROBIC DECOMPOSITION (AIR-O-bick)**

The decay or breaking down of organic material in the presence of "free" or dissolved oxygen.

**AEROBIC DECOMPOSITION****AEROBIC DIGESTION (AIR-O-bick)**

The breakdown of wastes by microorganisms in the presence of dissolved oxygen. Waste sludge is placed in a large aerated tank where aerobic microorganisms decompose the organic matter in the sludge. This is an extension of the activated sludge process.

**AEROBIC DIGESTION****AEROBIC PROCESS (AIR-O-bick)**

A waste treatment process conducted under aerobic (in the presence of "free" or dissolved oxygen) conditions.

**AEROBIC PROCESS****AGGLOMERATION (a-GLOM-er-A-shun)**

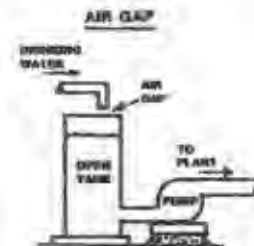
The growing or coming together of small scattered particles into larger flocs or particles which settle rapidly. Also see FLOC.

**AGGLOMERATION****AIR BINDING**

The clogging of a filter, pipe or pump due to the presence of air released from water.

**AIR BINDING****AIR GAP**

An open vertical drop, or vertical empty space, between a drinking (potable) water supply and the point of use in a wastewater treatment plant. This gap prevents back siphonage because there is no way wastewater can reach the drinking water.

**AIR GAP****AIR LIFT**

A special type of pump. This device consists of a vertical riser pipe submerged in the wastewater or sludge to be pumped. Compressed air is injected into a tail piece at the bottom of the pipe. Fine air bubbles mix with the wastewater or sludge to form a mixture lighter than the surrounding water which causes the mixture to rise in the discharge pipe to the outlet. An airlift pump works similar to the center stand in a percolator coffee pot.

**AIR LIFT****AIR PADDING**

Pumping dry air into a container to assist with the withdrawal of a liquid or to force a liquid gas such as chlorine or sulfur dioxide out of a container.

**AIR PADDING****ALGAE (AL-gee)**

Microscopic plants which contain chlorophyll and float or are suspended and live in water. They also may be attached to structures, rocks, or other similar substances.

**ALGAE****ALIQOT (AL-li-kwoi)**

Portion of a sample.

**ALIQOT****ALKALI**

Any of certain soluble salts, principally of sodium, potassium, magnesium, and calcium, that have the property of combining with acids to form neutral salts and may be used in chemical processes such as water or wastewater treatment.

**ALKALI****ALKALINITY (AL-ke-LIN-ity)**

The capacity of water or wastewater to neutralize acids. This capacity is caused by the water's content of carbonate, bicarbonate, hydroxide, and occasionally borate, silicate, and phosphate. Alkalinity is expressed in milligrams per liter of equivalent calcium carbonate. Alkalinity is not the same as pH because water does not have to be strongly basic (high pH) to have a high alkalinity. Alkalinity is a measure of how much acid can be added to a liquid without causing a great change in pH.

**ALKALINITY**



<b>AMBIENT TEMPERATURE</b> (AM-bee-ent)	<b>AMBIENT TEMPERATURE</b>
Temperature of the surroundings.	
<b>AMPEROMETRIC</b> (am-PURR-o-MET-rick)	<b>AMPEROMETRIC</b>
A method of measurement that records electric current flowing or generated, rather than recording voltage. Amperometric titration is a means of measuring concentrations of certain substances in water.	
<b>ANAEROBES</b>	<b>ANAEROBES</b>
Bacteria that do not need molecular (dissolved) oxygen (DO) to survive.	
<b>ANAEROBIC</b> (AN-air-O-bick)	<b>ANAEROBIC</b>
A condition in which "free" or dissolved oxygen is <i>NOT</i> present in the aquatic environment.	
<b>ANAEROBIC BACTERIA</b> (AN-air-O-bick back-TEAR-e-ah)	<b>ANAEROBIC BACTERIA</b>
Bacteria that live and reproduce in an environment containing no "free" or dissolved oxygen. Anaerobic bacteria obtain their oxygen supply by breaking down chemical compounds which contain oxygen, such as sulfates (SO <sub>4</sub> ).	
<b>ANAEROBIC DECOMPOSITION</b> (AN-air-O-bick)	<b>ANAEROBIC DECOMPOSITION</b>
The decay or breaking down of organic material in an environment containing no "free" or dissolved oxygen.	
<b>ANAEROBIC DIGESTION</b> (AN-air-O-bick)	<b>ANAEROBIC DIGESTION</b>
Wastewater solids and water (about 5% solids, 95% water) are placed in a large tank where bacteria decompose the solids in the absence of dissolved oxygen. At least two general groups of bacteria act in balance: (1) <i>SAPROPHYTIC</i> bacteria break down complex solids to volatile acids, and (2) <i>METHANE FERMENTERS</i> break down the acids to methane, carbon dioxide, and water.	
<b>ANHYDROUS</b> (an-HI-drous)	<b>ANHYDROUS</b>
Very dry. No water or dampness is present.	
<b>ANION</b>	<b>ANION</b>
A negatively charged ion in an electrolyte solution, attracted to the anode under the influence of electric potential.	
<b>ASEPTIC</b> (a-SEP-tick)	<b>ASEPTIC</b>
Free from the living germs of disease, fermentation or putrefaction. Sterile.	
<b>ASPIRATE</b> (ASS-per-RATE)	<b>ASPIRATE</b>
Use of a hydraulic device (aspirator or eductor) to create a negative pressure (suction) by forcing a liquid through a restriction, such as a Venturi. An aspirator (the hydraulic device) may be used in the laboratory in place of a vacuum pump; sometimes used instead of a sump pump.	
<b>BOD</b> (BEE-OH-DEE)	<b>BOD</b>
Biochemical Oxygen Demand. The rate at which microorganisms use the oxygen in water or wastewater while stabilizing decomposable organic matter under aerobic conditions. In decomposition, organic matter serves as food for the bacteria and energy results from its oxidation.	
<b>BTU</b> (BEE-TEA-YOU)	<b>BTU</b>
British Thermal Unit. The amount of heat required to raise the temperature of one pound of water one degree Fahrenheit.	
<b>BACTERIA</b> (back-TEAR-e-ah)	<b>BACTERIA</b>
Bacteria are living organisms, microscopic in size, which consist of a single cell. Most bacteria utilize organic matter for their food and produce waste products as the result of their life processes.	
<b>BACTERIAL CULTURE</b> (back-TEAR-e-ah)	<b>BACTERIAL CULTURE</b>
In the case of activated sludge, the bacterial culture refers to the group of bacteria classed as <i>AEROBES</i> , and facultative organisms, which covers a wide range of organisms. Most treatment processes in the United States grow facultative organisms which utilize the carbonaceous (carbon compounds) BOD. Facultative organisms can live when oxygen resources are low. When "nitrification" is required, the nitrifying organisms are <i>OBLIGATE AEROBES</i> (require oxygen) and must have at least 0.5 mg/L of dissolved oxygen throughout the whole system to function properly.	
<b>BAFFLE</b>	<b>BAFFLE</b>
A flat board or plate, deflector, guide or similar device constructed or placed in flowing water, wastewater, or slurry systems to cause more uniform flow velocities, to absorb energy, and to divert, guide, or agitate liquids.	



**BASE**

A compound which dissociates in aqueous solution to yield hydroxyl ions.

**BASE****BATCH PROCESS**

A treatment process in which a tank or reactor is filled, the water is treated, and the tank is emptied. The tank may then be filled and the process repeated.

**BATCH PROCESS****BIOASSAY (BUY-o-~~ass~~-SAY)**

(1) A way of showing or measuring the effect of biological treatment on a particular substance or waste, or (2) a method of determining toxic effects of industrial wastes or other wastes by using live organisms such as fish for test organisms.

**BIOASSAY****BIOCHEMICAL OXYGEN DEMAND (BOD)**

The rate at which microorganisms use the oxygen in water or wastewater while stabilizing decomposable organic matter under aerobic conditions. In decomposition, organic matter serves as food for the bacteria and energy results from its oxidation.

**BIOCHEMICAL OXYGEN DEMAND (BOD)****BIOCHEMICAL OXYGEN DEMAND (BOD) TEST**

A procedure that measures the rate of oxygen use under controlled conditions of time and temperature. Standard test conditions include dark incubation at 20°C for a specified time (usually five days).

**BIOCHEMICAL OXYGEN DEMAND (BOD) TEST****BIODEGRADABLE (BUY-o-~~des~~-GRADE-able)**

Organic matter that can be broken down by bacteria to more stable forms which will not create a nuisance or give off foul odors.

**BIODEGRADABLE****BIODEGRADATION (BUY-o-de-grah-DAY-shun)**

The breakdown of organic matter by bacteria to more stable forms which will not create a nuisance or give off foul odors.

**BIODEGRADATION****BIOFLOCCULATION (BUY-o-flock-u-LAY-shun)**

The clumping together of fine, dispersed organic particles by the action of certain bacteria and algae. This results in faster and more complete settling of the organic solids in wastewater.

**BIOFLOCCULATION****BIOMASS (BUY-o-MASS)**

A mass or clump of living organisms feeding on the wastes in wastewater, dead organisms and other debris. This mass may be formed for, or function as, the protection against predators and storage of food supplies. Also see ZOOGEAL MASS.

**BIOMASS****BLANK**

A bottle containing only dilution water or distilled water, but the sample being tested is not added. Tests are frequently run on a *SAMPLE* and a *BLANK* and the differences compared.

**BLANK****BLINDING**

The clogging of the filtering medium of a microscreen or a vacuum filter when the holes or spaces in the media become sealed off due to grease or the material being filtered.

**BLINDING****BOUND WATER**

Water contained within the cell mass of sludges or strongly held on the surface of colloidal particles.

**BOUND WATER****BREAKOUT OF CHLORINE**

A point at which chlorine leaves solution as a gas because the chlorine feed rate is too high. The solution is saturated and cannot dissolve any more chlorine.

**BREAKOUT OF CHLORINE****BREAKPOINT CHLORINATION**

Addition of chlorine to water or wastewater until the chlorine demand has been satisfied and further additions of chlorine result in a residual that is directly proportional to the amount added beyond the breakpoint.

**BREAKPOINT CHLORINATION****BUFFER**

A solution or liquid whose chemical makeup neutralizes acids or bases without a great change in pH.

**BUFFER****BUFFER ACTION**

The action of certain ions in solution in opposing a change in hydrogen-ion concentration.

**BUFFER ACTION****BUFFER CAPACITY**

A measure of the capacity of a solution or liquid to neutralize acids or bases. This is a measure of the capacity of water or wastewater for offering a resistance to changes in pH.

**BUFFER CAPACITY**



**BUFFER SOLUTION**

A solution containing two or more substances which, in combination, resist any marked change in pH following addition of moderate amounts of either strong acid or base.

**BUFFER SOLUTION****BULKING (BULK-ing)**

Clouds of billowing sludge that occur throughout secondary clarifiers and sludge thickeners when the sludge becomes too light and will not settle properly.

**BULKING****CALORIE (KAL-o-ree)**

The amount of heat required to raise the temperature of one gram of water one degree Celsius.

**CALORIE****CARBONACEOUS STAGE (car-bun-NAY-ahus)**

A stage of decomposition that occurs in biological treatment processes when aerobic bacteria, using dissolved oxygen, change carbon compounds to carbon dioxide. Sometimes referred to as "first-stage BOD" because the microorganisms attack organic or carbon compounds first and nitrogen compounds later. Also see NITRIFICATION STAGE.

**CARBONACEOUS****CATHODIC PROTECTION (ca-THOD-ick)**

An electrical system for prevention of rust, corrosion, and pitting of steel and iron surfaces in contact with water, wastewater or soil.

**CATHODIC PROTECTION****CATION EXCHANGE CAPACITY**

The ability of a soil or other solid to exchange cations (positive ions such as calcium,  $Ca^{+2}$ ) with a liquid.

**CATION EXCHANGE CAPACITY****CAVITATION (CAV-i-TAY-shun)**

The formation and collapse of a gas pocket or bubble on the blade of an impeller. The collapse of this gas pocket or bubble drives water into the impeller with a terrific force that can cause pitting on the impeller surface.

**CAVITATION****CENTRATE**

The water leaving a centrifuge after most of the solids have been removed.

**CENTRATE****CENTRIFUGE**

A mechanical device that uses centrifugal or rotational forces to separate solids from liquids.

**CENTRIFUGE****CHEMICAL EQUIVALENT**

The weight in grams of a substance that combines with or displaces one gram of hydrogen. Chemical equivalents usually are found by dividing the formula weight by its valence.

**CHEMICAL EQUIVALENT****CHEMICAL OXYGEN DEMAND or COD**

A measure of the oxygen-consuming capacity of inorganic and organic matter present in wastewater. COD is expressed as the amount of oxygen consumed from a chemical oxidant in mg/L during a specific test. Results are not necessarily related to the biochemical oxygen demand because the chemical oxidant may react with substances that bacteria do not stabilize.

**CHEMICAL OXYGEN DEMAND or COD****CHEMICAL PRECIPITATION**

(1) Precipitation induced by addition of chemicals. (2) The process of softening water by the addition of lime or lime and soda ash as the precipitants.

**CHEMICAL PRECIPITATION****CHLORAMINES (KLOR-a-means)**

Chloramines are compounds formed by the reaction of chlorine with ammonia.

**CHLORAMINES****CHLORINATION (KLOR-i-NAY-shun)**

The application of chlorine to water or wastewater, generally for the purpose of disinfection, but frequently for accomplishing other biological or chemical results.

**CHLORINATION****CHLORINE DEMAND**

Chlorine demand is the difference between the amount of chlorine added to wastewater and the amount of residual chlorine remaining after a given contact time. Chlorine demand may change with dosage, time, temperature, pH, and nature and amount of the impurities in the water.

**CHLORINE DEMAND**

$$\text{Chlorine Demand, mg/L} = \text{Chlorine Applied, mg/L} - \text{Chlorine Residual, mg/L}$$

**CHLORINE REQUIREMENT**

The amount of chlorine which is needed for a particular purpose. Some reasons for adding chlorine are reducing the number of coliform bacteria (Most Probable Number), obtaining a particular chlorine residual, or destroying some chemical in the water. In each case a definite dosage of chlorine will be necessary. This dosage is the chlorine requirement.

**CHLORINE REQUIREMENT**



<b>CHLORORGANIC</b> (chloro-or-GAN-nick)	<b>CHLORORGANIC</b>
Chlororganic compounds are organic compounds combined with chlorine. These compounds generally originate from, or are associated with, living or dead organic materials.	
<b>CILIATES</b> (SILLY-stes)	<b>CILIATES</b>
A class of protozoans distinguished by short hairs on all or part of their bodies.	
<b>CLARIFICATION</b> (KLAIR-i-fi-KAY-shun)	<b>CLARIFICATION</b>
Any process or combination of processes the main purpose of which is to reduce the concentration of suspended matter in a liquid.	
<b>CLARIFIER</b> (KLAIR-i-fire)	<b>CLARIFIER</b>
Settling Tank, Sedimentation Basin. A tank or basin in which wastewater is held for a period of time, during which the heavier solids settle to the bottom and the lighter material will float to the water surface.	
<b>COAGULANT AID</b>	<b>COAGULANT AID</b>
Any chemical or substance used to assist or modify coagulation.	
<b>COAGULANTS</b> (co-AGG-you-lents)	<b>COAGULANTS</b>
Chemicals that cause very fine particles to clump together into larger particles. This makes it easier to separate the solids from the liquids by settling, skimming, draining or filtering.	
<b>COAGULATION</b> (co-AGG-you-LAY-shun)	<b>COAGULATION</b>
The use of chemicals that cause very fine particles to clump together into larger particles. This makes it easier to separate the solids from the liquids by settling, skimming, draining or filtering.	
<b>COLIFORM</b> (COAL-i-form)	<b>COLIFORM</b>
One type of bacteria. The presence of coliform-group bacteria is an indication of possible pathogenic bacterial contamination. The human intestinal tract is one of the main habitats of coliform bacteria. They may also be found in the intestinal tracts of warm-blooded animals, and in plants, soil, air, and the aquatic environment. Fecal coliforms are those coliforms found in the feces of various warm-blooded animals; whereas the term "coliform" also includes other environmental sources.	
<b>COLLOIDS</b> (KOL-loids)	<b>COLLOIDS</b>
Very small, finely divided solids (particles that do not dissolve) that remain dispersed in a liquid for a long time due to their small size and electrical charge.	
<b>COLORIMETRIC MEASUREMENT</b>	<b>COLORIMETRIC MEASUREMENT</b>
A means of measuring unknown concentrations of water quality indicators in a sample by measuring the sample's color intensity. The color of the sample after the addition of specific chemicals (reagents) is compared with colors of known concentrations.	
<b>COMBINED AVAILABLE CHLORINE</b>	<b>COMBINED AVAILABLE CHLORINE</b>
The concentration of chlorine which is combined with ammonia (NH <sub>3</sub> ) as chloramine or as other chloro derivatives, yet is still available to oxidize organic matter.	
<b>COMBINED AVAILABLE RESIDUAL CHLORINE</b>	<b>COMBINED AVAILABLE RESIDUAL CHLORINE</b>
That portion of the total residual chlorine which remains in water or wastewater at the end of a specified contact period and reacts chemically and biologically as chloramines or organic chloramines.	
<b>COMBINED RESIDUAL CHLORINATION</b>	<b>COMBINED RESIDUAL CHLORINATION</b>
The application of chlorine to water or wastewater to produce a combined chlorine residual. The residual may consist of chlorine compounds formed by the reaction of chlorine with natural or added ammonia (NH <sub>3</sub> ) or with certain organic nitrogen compounds.	
<b>COMBINED SEWER</b>	<b>COMBINED SEWER</b>
A sewer designed to carry both sanitary wastewaters and storm- or surface-water runoff.	
<b>COMMINUTION</b> (com-mi-NEW-shun)	<b>COMMINUTION</b>
Shredding. A mechanical treatment process which cuts large pieces of wastes into smaller pieces so they won't plug pipes or damage equipment. <i>COMMINUTION</i> and <i>SHREDDING</i> usually mean the same thing.	
<b>COMMINUTOR</b> (com-mi-NEW-ter)	<b>COMMINUTOR</b>
A device used to reduce the size of the solid chunks in wastewater by shredding (comminuting). The shredding action is like many scissors cutting or chopping to shreds all the large influent solids material.	



**COMPOSITE (PROPORTIONAL) SAMPLE (com-POZ-it)**

A composite sample is a collection of individual samples obtained at regular intervals, usually every one or two hours during a 24-hour time span. Each individual sample is combined with the others in proportion to the flow when the sample was collected. The resulting mixture (composite sample) forms a representative sample and is analyzed to determine the average conditions during the sampling period.

**COMPOSITE (PROPORTIONAL) SAMPLE****COMPOUND**

A pure substance composed of two or more elements whose composition is constant. For example, table salt (sodium chloride - Na Cl) is a compound.

**COMPOUND****CONING (CONE-ing)**

Development of a cone-shaped flow of liquid, like a whirlpool, through sludge. This can occur in a sludge hopper during sludge withdrawal when the sludge becomes too thick. Part of the sludge remains in place while liquid rather than sludge flows out of the hopper. Also called "coring."

**CONING****CONTACT STABILIZATION**

Contact stabilization is a modification of the conventional activated sludge process. In contact stabilization, two aeration tanks are used. One tank is for separate re-aeration of the return sludge for at least four hours before it is permitted to flow into the other aeration tank to be mixed with the primary effluent requiring treatment.

**CONTACT STABILIZATION****CONTINUOUS PROCESS**

A treatment process in which water is treated continuously in a tank or reactor. The water being treated continuously flows into the tank at one end, is treated as it flows through the tank, and flows out the opposite end as treated water.

**CONTINUOUS PROCESS****CONVENTIONAL TREATMENT**

The pretreatment, sedimentation, flotation, trickling filter, activated sludge and chlorination wastewater treatment processes.

**CONVENTIONAL TREATMENT****CROSS CONNECTION**

A connection between drinking (potable) water and an unsafe water supply. For example, if you have a pump moving nonpotable water and hook into the drinking water system to supply water for the pump seal, a cross connection or mixing between the two water systems can occur. This mixing may lead to contamination of the drinking water.

**CROSS CONNECTION****CRYOGENIC (cry-o-JEN-nick)**

Low temperature.

**CRYOGENIC****DO (DEE-OH)**

Abbreviation of Dissolved Oxygen. DO is the atmospheric oxygen dissolved in water or wastewater.

**DO****DATEOMETER (day-TOM-uh-ter)**

A small calendar disc attached to motors and equipment to indicate the year in which the last maintenance service was performed.

**DATEOMETER****DECHLORINATION (dee-KLOR-I-NAY-shun)**

The removal of chlorine from the effluent of a treatment plant.

**DECHLORINATION****DECIBEL**

A unit for expressing the relative intensity of sounds on a scale from zero for the average least perceptible sound to about 130 for the average pain level.

**DECIBEL****DECOMPOSITION, DECAY**

Processes that convert unstable materials into more stable forms by chemical or biological action. Waste treatment encourages decay in a controlled situation so that material may be disposed of in a stable form. When organic matter decays under anaerobic conditions (putrefaction), undesirable odors are produced. The aerobic processes in common use for wastewater treatment produce much less objectional odors.

**DECOMPOSITION, DECAY****DEGRADATION (de-grah-DAY-shun)**

The conversion of a substance to simpler compounds. For example, the degradation of organic matter to carbon dioxide and water.

**DEGRADATION****DENITRIFICATION**

A condition that occurs when nitrite or nitrate ions are reduced to nitrogen gas and bubbles are formed as a result of this process. The bubbles attach to the biological flocs and float the flocs to the surface of the secondary clarifiers. This condition is often the cause of rising sludge observed in secondary clarifiers.

**DENITRIFICATION**



<b>DENSITY (DEN-sit-ee)</b>	<b>DENSITY</b>
A measure of how heavy a substance (solid, liquid or gas) is for its size. Density is expressed in terms of weight per unit volume, that is, grams per cubic centimeter or pounds per cubic foot. The density of water (at 4°C or 39°F) is 1.0 gram per cubic centimeter or about 62.4 pounds per cubic foot.	
<b>DESICCATOR (DESS-I-KAY-tor)</b>	<b>DESICCATOR</b>
A closed container into which heated weighing or drying dishes are placed to cool in a dry environment. The dishes may be empty or they may contain a sample. Desiccators contain a substance, such as anhydrous calcium chloride, which absorbs moisture and keeps the relative humidity near zero so that the dish or sample will not gain weight from absorbed moisture.	
<b>DETENTION TIME</b>	<b>DETENTION TIME</b>
The time required to fill a tank at a given flow or the theoretical time required for a given flow of wastewater to pass through a tank.	
<b>DETRITUS (dee-TRI-tus)</b>	<b>DETRITUS</b>
The heavy, coarse mixture of grit and organic material carried by wastewater.	
<b>DEW POINT</b>	<b>DEW POINT</b>
The temperature to which air with a given quantity of water vapor must be cooled to cause condensation of the vapor in the air.	
<b>DEWATER</b>	<b>DEWATER</b>
To remove or separate a portion of the water present in a sludge or slurry.	
<b>DEWATERABLE</b>	<b>DEWATERABLE</b>
This is a property of a sludge related to the ability to separate the liquid portion from the solid, with or without chemical conditioning. A material is considered dewaterable if water will readily drain from it.	
<b>DIAPHRAGM PUMP</b>	<b>DIAPHRAGM PUMP</b>
The pump in which a flexible diaphragm, generally of rubber or equally flexible material, is the operating part. It is fastened at the edges in a vertical cylinder. When the diaphragm is raised suction is exerted, and when it is depressed, the liquid is forced through a discharge valve.	
<b>DIFFUSED-AIR AERATION</b>	<b>DIFFUSED-AIR AERATION</b>
A diffused air activated sludge plant takes air, compresses it, and then discharges the air below the water surface of the aerator through some type of air diffusion device.	
<b>DIFFUSER</b>	<b>DIFFUSER</b>
A device (porous plate, tube, bag) used to break the air stream from the blower system into fine bubbles in an aeration tank or reactor.	
<b>DIGESTER (die-JEST-er)</b>	<b>DIGESTER</b>
A tank in which sludge is placed to allow decomposition by microorganisms. Digestion may occur under anaerobic (more common) or aerobic conditions.	
<b>DISCHARGE HEAD</b>	<b>DISCHARGE HEAD</b>
The pressure (in feet (meters) or pounds per square inch (kilograms per square centimeter)) on the discharge side of a pump. The pressure can be measured from the center line of the pump to the hydraulic grade line of the water in the discharge pipe.	
<b>DISINFECTION (dis-in-FECT-shun)</b>	<b>DISINFECTION</b>
The process designed to kill most microorganisms in wastewater, including essentially all pathogenic (disease-causing) bacteria. There are several ways to disinfect, with chlorine being most frequently used in water and wastewater treatment plants. Compare with <b>STERILIZATION</b> .	
<b>DISSOLVED OXYGEN</b>	<b>DISSOLVED OXYGEN</b>
Molecular oxygen dissolved in water or wastewater, usually abbreviated DO.	
<b>DISTILLATE (DIS-tuh-late)</b>	<b>DISTILLATE</b>
In the distillation of a sample, a portion is evaporated; the part that is condensed afterwards is the distillate.	
<b>DISTRIBUTOR</b>	<b>DISTRIBUTOR</b>
The rotating mechanism that distributes the wastewater evenly over the surface of a trickling filter or other process unit. Also see <b>FIXED SPRAY NOZZLE</b> .	



**DOCTOR BLADE**

A blade used to remove any excess solids that may cling to the outside of a rotating screen.

**DOCTOR BLADE****DROOP**

The difference between the actual value and the desired value (or set point) characteristics of proportional controllers that do not incorporate reset action. Also called **OFFSET**.

**DROOP****DYNAMIC HEAD**

When a pump is operating, the vertical distance (in feet or meters) from a point to the energy grade lines. Also see **TOTAL DYNAMIC HEAD** and **STATIC HEAD**.

**DYNAMIC HEAD****EDUCTOR (e-DUCK-tor)**

A hydraulic device used to create a negative pressure (suction) by forcing a liquid through a restriction, such as a Venturi. An eductor or aspirator (the hydraulic device) may be used in the laboratory in place of a vacuum pump; sometimes used instead of a suction pump.

**EDUCTOR****EFFLORESCENCE (EF-low-RESS-ense)**

The powder or crust formed on a substance when moisture is given off upon exposure to the atmosphere.

**EFFLORESCENCE****EFFLUENT (EF-lu-ent)**

Wastewater or other liquid — raw, partially or completely treated — flowing *FROM* a basin, treatment process, or treatment plant.

**EFFLUENT****ELECTRO-CHEMICAL PROCESS**

A process that causes the deposition or formation of a seal or coating of a chemical element or compound by the use of electricity.

**ELECTRO-CHEMICAL PROCESS****ELECTRO-MAGNETIC FORCES**

Forces resulting from electrical charges that either attract or repel particles. Particles with opposite charges are attracted to each other. For example, a particle with positive charges is attracted to a particle with negative charges. Particles with similar charges repel each other. A particle with positive charges is repelled by a particle with positive charges and a particle with negative charges is repelled by another particle with negative charges.

**ELECTRO-MAGNETIC FORCES****ELECTROLYSIS (ELECT-TROLLEY-sis)**

The decomposition of material by an electric current.

**ELECTROLYSIS****ELECTROLYTE (ELECT-tro-LIGHT)**

A substance which dissociates (separates) into two or more ions when it is dissolved in water.

**ELECTROLYTE****ELECTROLYTIC PROCESS (ELECT-tro-LIT-ick)**

A process that causes the decomposition of a chemical compound by the use of electricity.

**ELECTROLYTIC PROCESS****ELECTRON**

An extremely small (microscopic), negatively charged particle. An electron is much too small to be seen with a microscope.

**ELECTRON****ELEMENT**

A substance which cannot be separated into substances of other kinds by ordinary chemical means. For example, sodium (Na) is an element.

**ELEMENT****ELUTRIATION (e-LOO-tree-A-shun)**

The washing of digested sludge in plant effluent. The objective is to remove (wash out) fine particulates and/or alkalinity in sludge. This process reduces the demand for conditioning chemicals and improves settling or filtering characteristics of the solids.

**ELUTRIATION****EMULSION (e-MULL-shun)**

A liquid mixture of two or more liquid substances not normally dissolved in one another, but one liquid held in suspension in the other.

**EMULSION****END POINT**

Samples are titrated to the end point. This means that a chemical is added, drop by drop, to a sample until a certain color change (blue to clear, for example) occurs which is called the *END POINT* of the titration. In addition to a color change, an end point may be reached by the formation of a precipitate or the reaching of a specified pH. An end point may be detected by the use of an electronic device such as a pH meter.

**END POINT**



**ENDOGENOUS (en-DODGE-en-us)**

A reduced level of respiration (breathing) in which organisms break down compounds within their own cells to produce the oxygen they need.

**ENDOGENOUS****ENERGY GRADE LINE (EGL)**

A line that represents the elevation of energy head (in feet) of water flowing in a pipe, conduit or channel. The line is drawn above the hydraulic grade line a distance equal to the velocity head of the water flowing at each section or point along the pipe or channel.

**ENERGY GRADE LINE (EGL)****ENTERIC**

Intestinal.

**ENTERIC****ENZYMES (EN-zymes)**

Enzymes are organic substances which are produced by living organisms and speed up chemical changes.

**ENZYMES****EQUALIZING BASIN**

A holding basin in which variations in flow and composition of liquid are averaged. Such basins are used to provide a flow of reasonably uniform volume and composition to a treatment unit. Also called a balancing reservoir.

**EQUALIZING BASIN****ESTUARIES (ES-chew-wear-eez)**

Bodies of water which are located at the lower end of a river and are subject to tidal fluctuations.

**ESTUARIES****EVAPOTRANSPIRATION (e-VAP-o-trans-pi-RAY-shun)**

The total water removed from an area by transpiration (plants) and by evaporation from soil, snow and water surfaces.

**EVAPOTRANSPIRATION****EXPLOSIMETER**

An instrument used to detect explosive atmospheres. When the Lower Explosive Limit (L.E.L.) of an atmosphere is exceeded, an alarm signal on the instrument is activated.

**EXPLOSIMETER****F/M RATIO**

Food to microorganism ratio. A measure of food provided to bacteria in an aeration tank.

**F/M RATIO**

$$\frac{\text{Food}}{\text{Microorganisms}} = \frac{\text{BOD, lbs/day}}{\text{MLVSS, lbs}}$$

$$= \frac{\text{Flow, MGD} \times \text{BOD, mg/L} \times 8.34 \text{ lbs/gal}}{\text{Volume, MG} \times \text{MLVSS, mg/L} \times 8.34 \text{ lbs/gal}}$$

$$\text{or} = \frac{\text{BOD, kg/day}}{\text{MLVSS, kg}}$$

**FACULTATIVE (FACK-ul-TAY-tive)**

Facultative bacteria can use either molecular (dissolved) oxygen or oxygen obtained from food materials such as sulfate or nitrate ions. In other words, facultative bacteria can live under aerobic or anaerobic conditions.

**FACULTATIVE****FACULTATIVE POND (FACK-ul-TAY-tive)**

The most common type of pond in current use. The upper portion (supernatant) is aerobic, while the bottom layer is anaerobic. Algae supply most of the oxygen to the supernatant.

**FACULTATIVE POND****FILAMENTOUS BACTERIA (FILL-s-MEN-tuss)**

Organisms that grow in a thread or filamentous form. Common types are thiothrix and actinomyces.

**FILAMENTOUS BACTERIA****FILTER AID**

A chemical (usually a polymer) added to water to help remove fine colloidal suspended solids.

**FILTER AID****FIXED**

A sample is "fixed" in the field by adding chemicals that prevent the water quality indicators of interest in the sample from changing before final measurements are performed later in the lab.

**FIXED****FIXED SPRAY NOZZLE**

Cone-shaped spray nozzle used to distribute wastewater over the filter media, similar to a lawn sprinkling system. A deflector or steel ball is mounted within the cone to spread the flow of wastewater through the cone, thus causing a spraying action. Also see DISTRIBUTOR.

**FIXED SPRAY NOZZLE**



**FLAME POLISHED**

Melted by a flame to smooth out irregularities. Sharp or broken edges of glass (such as the end of a glass tube) are rotated in a flame until the edge melts slightly and becomes smooth.

**FLIGHTS**

Scraper boards, made from redwood or other rot-resistant woods or plastic, used to collect and move settled sludge or floating scum.

**FLOC**

Groups or clumps of bacteria and particles that have come together and formed a cluster. Found in aeration tanks and secondary clarifiers.

**FLOCCULATION (FLOCK-you-LAY-shun)**

The gathering together of fine particles to form larger particles.

**FLOW-EQUALIZATION SYSTEM**

A device or tank designed to hold back or store a portion of peak flows for release during low-flow periods.

**FOOD/MICROORGANISM RATIO**

Food to microorganism ratio. A measure of food provided to bacteria in an aeration tank.

$$\frac{\text{Food}}{\text{Microorganisms}} = \frac{\text{BOD, lbs/day}}{\text{MLVSS, lbs}}$$

$$= \frac{\text{Flow, MGD} \times \text{BOD, mg/L} \times 8.34 \text{ lbs/gal}}{\text{Volume, MG} \times \text{MLVSS, mg/L} \times 8.34 \text{ lbs/gal}}$$

or

$$= \frac{\text{BOD, kg/day}}{\text{MLVSS, kg}}$$

Commonly abbreviated F/M Ratio.

**FORCE MAIN**

A pipe that conveys wastewater under pressure from the discharge side of a pump to a point of gravity flow.

**FREE AVAILABLE CHLORINE**

The amount of chlorine available in water. This chlorine may be in the form of dissolved gas ( $\text{Cl}_2$ ), hypochlorous acid ( $\text{HOCl}$ ), or hypochlorite ion ( $\text{OCl}^-$ ), but does not include chlorine combined with an amine (ammonia or nitrogen) or other organic compound.

**FREE AVAILABLE RESIDUAL CHLORINE**

That portion of the total residual chlorine remaining in water or wastewater at the end of a specified contact period. Residual chlorine will react chemically and biologically as hypochlorous acid ( $\text{HOCl}$ ) or hypochlorite ion ( $\text{OCl}^-$ ).

**FREE CHLORINE**

Free chlorine is chlorine ( $\text{Cl}_2$ ) in a liquid or gaseous form. Free chlorine combines with water to form hypochlorous ( $\text{HOCl}$ ) and hydrochloric ( $\text{HCl}$ ) acids. In wastewater free chlorine usually combines with an amine (ammonia or nitrogen) or other organic compounds to form combined chlorine compounds.

**FREE OXYGEN**

Molecular oxygen available for respiration by organisms. Molecular oxygen is the oxygen molecule,  $\text{O}_2$ , that is not combined with another element to form a compound.

**FREE RESIDUAL CHLORINATION**

The application of chlorine or chlorine compounds to water or wastewater to produce a free available chlorine residual directly or through the destruction of ammonia ( $\text{NH}_3$ ) or certain organic nitrogenous compounds.

**FREEBOARD**

The vertical distance from the normal water surface to the top of the confining wall.

**FRICTION LOSS**

The head lost by water flowing in a stream or conduit as the result of the disturbances set up by the contact between the moving water and its containing conduit and by intermolecular friction.



**GASIFICATION (GAS-I-I-KAY-shun)**

The conversion of soluble and suspended organic materials into gas during anaerobic decomposition. In clarifiers the resulting gas bubbles can become attached to the settled sludge and cause large clumps of sludge to rise and float on the water surface. In anaerobic sludge digesters, this gas is collected for fuel or disposed of using the waste gas burner.

**GASIFICATION****GRAB SAMPLE**

A single sample of wastewater taken at neither a set time nor flow.

**GRAB SAMPLE****GRAVIMETRIC**

A means of measuring unknown concentrations of water quality indicators in a sample by *WEIGHING* a precipitate or residue of the sample.

**GRAVIMETRIC****GRIT**

The heavy mineral material present in wastewater, such as sand, eggshells, gravel, and cinders.

**GRIT****GRIT REMOVAL**

Grit removal is accomplished by providing an enlarged channel or chamber which causes the flow velocity to be reduced and allows the heavier grit to settle to the bottom of the channel where it can be removed.

**GRIT REMOVAL****GROWTH RATE**

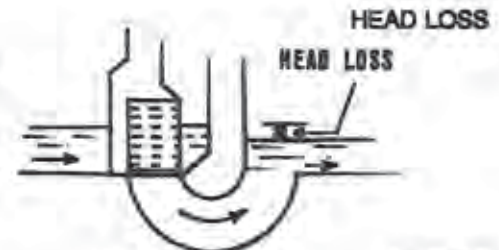
An experimentally determined constant to estimate the unit growth rate of bacteria while degrading organic wastes.

**GROWTH RATE****HEAD**

A term used to describe the height or energy of water above a point. A head of water may be measured in either height (feet or meters) or pressure (pounds per square inch or kilograms per square centimeter). Also see *DISCHARGE HEAD*, *DYNAMIC HEAD*, *STATIC HEAD*, *SUCTION HEAD*, *SUCTION LIFT* and *VELOCITY HEAD*.

**HEAD****HEAD LOSS**

An indirect measure of loss of energy or pressure. Flowing water will lose some of its energy when it passes through a pipe, bar screen, comminutor, filter or other obstruction. The amount of energy or pressure lost is called "head loss." Head loss is measured as the difference in elevation between the upstream water surface and the downstream water surface and may be expressed in feet or meters.

**HEAD LOSS****HEADER**

A large pipe to which the ends of a series of smaller pipes are connected. Also called a "manifold."

**HEADER****HEADWORKS**

The facilities where wastewater enters a wastewater treatment plant. The headworks may consist of bar screens, comminutors, a wet well and pumps.

**HEADWORKS****HEPATITIS**

Hepatitis is an acute viral infection of the liver. Yellow jaundice is one symptom of hepatitis.

**HEPATITIS****HUMUS SLUDGE**

The sloughed particles of biomass from trickling filter media that are removed from the water being treated in secondary clarifiers.

**HUMUS SLUDGE****HYDRAULIC GRADE LINE (HGL)**

The surface or profile of water flowing in an open channel or a pipe flowing partially full. If a pipe is under pressure, the hydraulic grade line is at the level water would rise to in a small tube connected to the pipe. To reduce the release of odors from wastewater, the water surface should be kept as smooth as possible.

**HYDRAULIC GRADE LINE (HGL)****HYDRAULIC LOADING**

Hydraulic loading refers to the flows (MGD or cu m/day) to a treatment plant or treatment process. Detention times, surface loadings and weir overflow rates are directly influenced by flows.

**HYDRAULIC LOADING****HYDROGEN ION CONCENTRATION (H<sup>+</sup>)**

The weight of hydrogen ion in moles per liter of solution. Commonly expressed as the pH value, which is the logarithm of the reciprocal of the hydrogen-ion concentration.

**HYDROGEN ION CONCENTRATION (H<sup>+</sup>)**

$$\text{pH} = \log \frac{1}{(\text{H}^+)}$$



**HYDROGEN SULFIDE (H<sub>2</sub>S)**

Hydrogen sulfide is a gas with a rotten egg odor. This gas is produced under anaerobic conditions. Hydrogen sulfide is particularly dangerous because it dulls your sense of smell so that you don't notice it after you have been around it for a while and because the odor is not noticeable in high concentrations. The gas is very poisonous to your respiratory system, explosive, flammable and colorless.

**HYDROGEN SULFIDE (H<sub>2</sub>S)****HYDROLOGIC CYCLE (HI-dro-loj-ic)**

The process of evaporation of water into the air and its return to earth by precipitation (rain or snow). This process also includes transpiration from plants, groundwater movement and runoff into rivers, streams and the ocean.

**HYDROLOGIC CYCLE****HYDROLYSIS (hi-DROL-a-sis)**

The addition of water to the molecule to break down complex substances into simpler ones.

**HYDROLYSIS****HYDROSTATIC SYSTEM**

In a hydrostatic sludge removal system, the surface of the water in the clarifier is higher than the surface of the water in the sludge well or hopper. This difference in pressure head forces sludge from the bottom of the clarifier to flow through pipes to the sludge well or hopper.

**HYDROSTATIC SYSTEM****HYGROSCOPIC (HI-grow-SKOP-ic)**

A substance that absorbs or attracts moisture from the air.

**HYGROSCOPIC****HYPOCHLORINATION (hi-po-KLOR-i-NAY-shun)**

The application of hypochlorite compounds to water or wastewater for the purpose of disinfection.

**HYPOCHLORINATION****HYPOCHLORINATORS (hi-poe-KLOR-i-NAY-tors)**

Chlorine pumps or devices used to feed chlorine solutions made from hypochlorites such as bleach (sodium hypochlorite) or calcium hypochlorite.

**HYPOCHLORINATORS****HYPOCHLORITE (hi-po-KLOR-ite)**

Hypochlorite compounds contain chlorine and are used for disinfection. They are available as liquids or solids (powder, granules, and pellets) in barrels, drums, and cans.

**HYPOCHLORITE****IMHOFF CONE**

A clear, cone-shaped container marked with graduations. The cone is used to measure the volume of settleable solids in a specific volume of wastewater.

**IMHOFF CONE****IMPELLER**

A rotating set of vanes designed to impel rotation of a mass of fluid.

**IMPELLER****IMPELLER PUMP**

Any pump in which the water is moved by the continuous application of power from some mechanical source.

**IMPELLER PUMP****INCINERATION**

The conversion of dewatered sludge cake by combustion (burning) to ash, carbon dioxide and water vapor.

**INCINERATION****INDICATOR (CHEMICAL)**

A substance that gives a visible change, usually of color, at a desired point in a chemical reaction, generally at a specified end point.

**INDICATOR (CHEMICAL)****INDOLE (IN-dole)**

An organic compound (C<sub>8</sub>H<sub>7</sub>N) containing nitrogen which has an ammonia odor.

**INDOLE****INFILTRATION (IN-fil-TRAY-shun)**

The seepage of groundwater into a sewer system, including service connections. Seepage frequently occurs through defective or cracked pipes, pipe joints, connections or manhole walls.

**INFILTRATION****INFLOW**

Water discharged into the sewer system from sources other than regular connections. This includes flow from yard drains, foundation drains and around manhole covers. Inflow differs from infiltration in that it is a direct discharge into the sewer rather than a leak in the sewer itself.

**INFLOW****INFLUENT (IN-fiu-ent)**

Wastewater or other liquid — raw or partially treated — flowing INTO a reservoir, basin, treatment process, or treatment plant.

**INFLUENT**



**INHIBITORY SUBSTANCES**

Materials that kill or restrict the ability of organisms to treat wastes.

**INOCULATE (in-NOCK-you-late)**

To introduce a seed culture into a system.

**INORGANIC WASTE**

Waste material such as sand, salt, iron, calcium, and other mineral materials which are only slightly affected by the action of organisms. Inorganic wastes are chemical substances of mineral origin; whereas organic wastes are chemical substances usually of animal or plant origin. Also see **NONVOLATILE MATTER**.

**INTERFACE**

The common boundary layer between two fluids such as a gas (air) and a liquid (water) or a liquid (water) and another liquid (oil).

**IONIC CONCENTRATION**

The concentration of any ion in solution, generally expressed in moles per liter.

**IONIZATION**

The process of adding electrons to, or removing electrons from, atoms or molecules, thereby creating ions. High temperatures, electrical discharges, and nuclear radiation can cause ionization.

**JAR TEST**

A laboratory procedure that simulates coagulation/flocculation with differing chemical doses. The purpose of the procedure is to *ESTIMATE* the minimum coagulant dose required to achieve certain water quality goals. Samples of water to be treated are placed in six jars. Various amounts of chemicals are added to each jar, stirred and the settling of solids is observed. The lowest dose of chemicals that provides satisfactory settling is the dose used to treat the water.

**JOULE (jewel)**

A measure of energy, work or quantity of heat. One joule is the work done when the point of application of a force of one newton is displaced a distance of one meter in the direction of the force.

**KJELDAHL NITROGEN (KELL-doll)**

Organic and ammonia nitrogen.

**LAUNDERS (LAWN-ders)**

Sedimentation tank effluent troughs.

**LIMIT SWITCH**

A device that regulates or controls the travel distance of a chain or cable.

**LINEAL (LIN-a-el)**

The length in one direction of a line. For example, a board 12 feet long has 12 lineal feet in its length.

**LIQUEFACTION (LICK-ws-FACK-shun)**

The conversion of large solid particles of sludge into very fine particles which either dissolve or remain suspended in wastewater.

**LOADING**

Quantity of material applied to a device at one time.

**M or MOLAR**

A molar solution consists of one gram molecular weight of a compound dissolved in enough water to make one liter of solution. A gram molecular weight is the molecular weight of a compound in grams. For example, the molecular weight of sulfuric acid ( $H_2SO_4$ ) is 98. A 1M solution of sulfuric acid would consist of 98 grams of  $H_2SO_4$  dissolved in enough distilled water to make one liter of solution.

**MBAS**

Methylene Blue Active Substance. Another name for surfactants, or surface active agents, is methylene blue active substances. The determination of surfactants is accomplished by measuring the color change in a standard solution of methylene blue dye.

**MPN (EM-PEA-EN)**

MPN is the Most Probable Number of coliform-group organisms per unit volume. Expressed as a density or population of organisms per 100 ml.

**INHIBITORY SUBSTANCES****INOCULATE****INORGANIC WASTE****INTERFACE****IONIC CONCENTRATION****IONIZATION****JAR TEST****JOULE****KJELDAHL NITROGEN****LAUNDERS****LIMIT SWITCH****LINEAL****LIQUEFACTION****LOADING****M or MOLAR****MBAS****MPN**

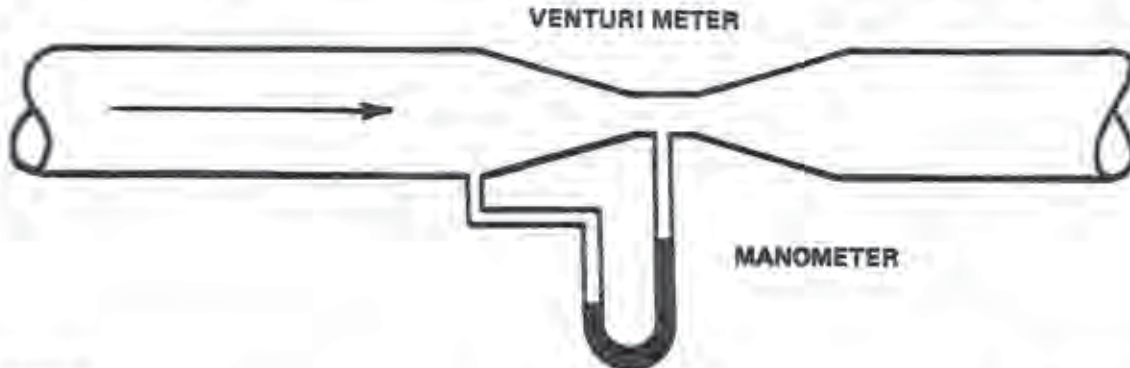


**MANIFOLD**

A large pipe to which the ends of a series of smaller pipes are connected. Also called a "header."

**MANIFOLD****MANOMETER (man-NAH-met-ter)**

An instrument for measuring pressure. Usually a glass tube filled with a liquid and used to measure the difference in pressure across a flow-measuring device such as an orifice or Venturi meter. The instrument used to measure blood pressure is a type of manometer.

**MANOMETER****MASKING AGENTS**

Substances used to cover up or disguise unpleasant odors. Liquid masking agents are dripped into the wastewater, sprayed into the air, or evaporated (using heat) with the unpleasant fumes or odors and then discharged into the air by blowers to make an undesirable odor less noticeable.

**MASKING AGENTS****MEAN CELL RESIDENCE TIME (MCRT)**

An expression of the average time that a microorganism will spend in the activated sludge process.

**MEAN CELL RESIDENCE TIME (MCRT)**

$$\text{MCRT, days} = \frac{\text{Solids in Activated Sludge Process, lbs}}{\text{Solids Removed from Process, lbs/day}}$$

**MECHANICAL AERATION**

The use of machinery to mix air and water so that oxygen can be absorbed into the water. Some examples are: paddle wheels, mixers, or rotating brushes to agitate the surface of an aeration tank; pumps to create fountains; and pumps to discharge water down a series of steps forming falls or cascades.

**MECHANICAL AERATION****MEDIA**

The material in a trickling filter on which slime organisms grow. As settled wastewater trickles over the media, slime organisms remove certain types of wastes thereby partially treating the wastewater. Also the material in a rotating biological contactor or in a gravity or pressure filter.

**MEDIA****MEDIAN**

The middle measurement or value. When several measurements are ranked by magnitude (largest to smallest), half of the measurements will be larger and half will be smaller.

**MEDIAN****MENISCUS (meh-NIS-cuss)**

The curved top of a column of liquid (water, oil, mercury) in a small tube. When the liquid wets the sides of the container (as with water), the curve forms a valley. When the confining sides are not wetted (as with mercury), the curve forms a hill or upward bulge.

**MENISCUS****MERCAPTANS (mer-CAP-tans)**

Compounds containing sulfur which have an extremely offensive skunk odor.

**MERCAPTANS****MESOPHILIC BACTERIA (mess-O-FILL-lick)**

Medium temperature bacteria. A group of bacteria that grow and thrive in a moderate temperature range between 68°F (20°C) and 113°F (45°C). The optimum temperature range for these bacteria in anaerobic digestion is 85°F (30°C) to 100°F (38°C).

**MESOPHILIC BACTERIA**



**MICRON (MY-kron)****MICRON**

A unit of length. One millionth of a meter or one thousandth of a millimeter. One micron equals 0.00004 of an inch.

**MICROORGANISMS (micro-ORGAN-is-isms)****MICROORGANISMS**

Very small organisms that can be seen only through a microscope. Some microorganisms use the wastes in wastewater for food and thus remove or alter much of the undesirable matter.

**MICROSCREEN****MICROSCREEN**

A device with a fabric straining media with openings usually between 20 and 60 microns. The fabric is wrapped around the outside of a rotating drum. Wastewater enters the open end of the drum and flows out through the rotating screen cloth. At the highest point of the drum the collected solids are backwashed by high-pressure water jets into a trough located within the drum.

**MILLIGRAMS PER LITER, mg/L (MILL-i-GRAMS per LEET-er)****MILLIGRAMS PER LITER, mg/L**

A measure of the concentration by weight of a substance per unit volume. For practical purposes, one mg/L is equal to one part per million parts (ppm). Thus a liter of water with a specific gravity of 1.0 weighs one million milligrams; and if it contains 10 milligrams of dissolved oxygen, the concentration is 10 milligrams per million milligrams, or 10 milligrams per liter (10 mg/L), or 10 parts of oxygen per million parts of water, or 10 parts per million (10 ppm).

**MILLIMICRON (MILL-s-MY-cron)****MILLIMICRON**

One thousandth of a micron or a millionth of a millimeter.

**MIXED LIQUOR****MIXED LIQUOR**

When the activated sludge in an aeration tank is mixed with primary effluent or the raw wastewater and return sludge, this mixture is then referred to as mixed liquor as long as it is in the aeration tank. Mixed liquor also may refer to the contents of mixed aerobic or anaerobic digesters.

**MIXED LIQUOR SUSPENDED SOLIDS (MLSS)****MIXED LIQUOR SUSPENDED SOLIDS (MLSS)**

Suspended solids in the mixed liquor of an aeration tank.

**MIXED LIQUOR VOLATILE SUSPENDED SOLIDS (MLVSS)****MIXED LIQUOR VOLATILE SUSPENDED SOLIDS (MLVSS)**

The organic or volatile suspended solids in the mixed liquor of an aeration tank.

**MOLECULAR OXYGEN****MOLECULAR OXYGEN**

The oxygen molecule, O<sub>2</sub>, that is not combined with another element to form a compound.

**MOLECULAR WEIGHT****MOLECULAR WEIGHT**

The molecular weight of a compound in grams is the sum of the atomic weights of the elements in the compound. The molecular weight of sulfuric acid (H<sub>2</sub>SO<sub>4</sub>) in grams is 98.

Element	Atomic Weight	Number of Atoms	Molecular Weight
H	1	2	2
S	32	1	32
O	16	4	64
			<hr/> 98

**MOLECULE (MOLL-uh-kule)****MOLECULE**

A molecule is the smallest portion of an element or compound that still retains or exhibits all the properties of the substance.

**MOTILE (MO-till)****MOTILE**

Motile organisms exhibit or are capable of movement.

**MOVING AVERAGE****MOVING AVERAGE**

To calculate the moving average for the last 7 days, add up values for the last 7 days and divide by 7. Each day add the most recent day to the sum of values and subtract the oldest value. By using the 7-day moving average, each day of the week is always represented in the calculations.

**MUFFLE FURNACE****MUFFLE FURNACE**

A small oven capable of reaching temperatures up to 800°C. Muffle furnaces are used in laboratories for burning or incinerating samples to determine the amounts of volatile solids and/or fixed solids in samples of wastewater.

**MULTI-STAGE PUMP****MULTI-STAGE PUMP**

A pump that has more than one impeller. A single-stage pump has one impeller.



**N or NORMAL**

A normal solution contains one gram equivalent weight of a reactant (compound) per liter of solution. The equivalent weight of an acid is that weight which contains one gram atom of ionizable hydrogen or its chemical equivalent. For example, the equivalent weight of sulfuric acid ( $H_2SO_4$ ) is 49 (98 divided by 2 because there are two replaceable hydrogen ions). A 1 N solution of sulfuric acid would consist of 49 grams of  $H_2SO_4$  dissolved in enough water to make one liter of solution.

**NPDES PERMIT**

National Pollutant Discharge Elimination System permit is the regulatory agency document designed to control all discharges of pollutants from point sources into U.S. waterways. NPDES permits regulate discharges into navigable waters from all point sources of pollution, including industries, municipal treatment plants, large agricultural feed lots and return irrigation flows.

**NEUTRALIZATION (new-trail-i-ZAY-shun)**

Addition of an acid or alkali (base) to a liquid to cause the pH of the liquid to move towards a neutral pH of 7.0.

**NITRIFICATION (NYE-tri-fi-KAY-shun)**

A process in which bacteria change the ammonia and organic nitrogen in wastewater into oxidized nitrogen (usually nitrate). The second-stage BOD is sometimes referred to as the "nitrification stage" (first-stage BOD is called the "carbonaceous stage").

**NITRIFYING BACTERIA**

Bacteria that change the ammonia and organic nitrogen in wastewater into oxidized nitrogen (usually nitrate).

**NITROGENOUS (nye-TROG-en-ous)**

Nitrogenous compounds contain nitrogen.

**NOMOGRAM**

A chart or diagram containing three or more scales used to solve problems with three or more variables instead of using mathematical formulas.

**NONCORRODIBLE**

A material that resists corrosion and will not be eaten away by wastewater or chemicals in wastewater.

**NONSPARKING TOOLS**

These tools will not produce a spark during use.

**NONVOLATILE MATTER**

Material such as sand, silt, iron, calcium, and other mineral materials which are only slightly affected by the action of organisms. Volatile materials are chemical substances usually of animal or vegetable origin. Also see INORGANIC WASTE.

**NUTRIENT CYCLE**

The transformation or change of a nutrient from one form to another until the nutrient has returned to the original form, thus completing the cycle. The cycle may take place under either aerobic or anaerobic conditions.

**NUTRIENTS**

Substances which are required to support living plants and organisms. Major nutrients are carbon, hydrogen, oxygen, sulfur, nitrogen and phosphorus. Nitrogen and phosphorus are difficult to remove from wastewater by conventional treatment processes because they are water soluble and tend to recycle. Also see NUTRIENT CYCLE.

**O & M MANUAL (Operation and Maintenance Manual)**

A manual which outlines procedures for operators to follow to operate and maintain a specific wastewater treatment plant and the equipment in the plant.

**OSHA**

The Williams-Steiger Occupational Safety and Health Act of 1970 (OSHA) is a law designed to protect the health and safety of industrial workers and treatment plant operators. It regulates the design, construction, operation and maintenance of industrial plants and wastewater treatment plants. The Act does not apply directly to municipalities at present (1980), EXCEPT in those states that have approved plans and have asserted jurisdiction under Section 18 of the OSHA Act. However, wastewater treatment plants have come under stricter regulation in all phases of activity as a result of OSHA standards.

**OBLIGATE AEROBES**

Bacteria that must have molecular (dissolved) oxygen (DO) to reproduce.

**ODOR PANEL**

A group of people used to measure odors.

**N or NORMAL****NPDES PERMIT****NEUTRALIZATION****NITRIFICATION****NITRIFYING BACTERIA****NITROGENOUS****NOMOGRAM****NONCORRODIBLE****NONSPARKING TOOLS****NONVOLATILE MATTER****NUTRIENT CYCLE****NUTRIENTS****O & M MANUAL****OSHA****OBLIGATE AEROBES****ODOR PANEL**



**OFFSET**

The difference between the actual value and the desired value (or set point) characteristic of proportional controllers that do not incorporate reset action. Also called DROOP.

**OFFSET****OLFACTOMETER (ol-FACT-om-meter)**

A device used to measure odors in the field by diluting odors with odor-free air.

**OLFACTOMETER****ORGANIC WASTE**

Waste material which comes mainly from animal or plant sources. Organic waste generally can be consumed by bacteria and other small organisms. Inorganic wastes are chemical substances of mineral origin.

**ORGANIC WASTE****ORGANISM**

Any form of animal or plant life. Also see BACTERIA.

**ORGANISM****ORIFICE (OR-uh-fiss)**

An opening in a plate, wall or partition. In a trickling filter distributor, the wastewater passes through an orifice to the surface of the filter media. An orifice flange set in a pipe consists of a slot or hole smaller than the pipe diameter. The difference in pressure in the pipe above and at the orifice may be related to flow in the pipe.

**ORIFICE****ORTHOTOLIDINE (or-tho-TOL-i-dine)**

Orthotolidine is a colorimetric indicator of chlorine residual. If chlorine is present, a yellow-colored compound is produced. This method is no longer approved for tests of effluent chlorine residual.

**ORTHOTOLIDINE****OVERFLOW RATE**

One of the guidelines for the design of settling tanks and clarifiers in treatment plants.

**OVERFLOW RATE**

$$\text{Overflow Rate, gpd/sq ft} = \frac{\text{Flow, gallons/day}}{\text{Surface Area, sq ft}}$$

**OXIDATION (ox-i-DAY-shun)**

Oxidation is the addition of oxygen, removal of hydrogen, or the removal of electrons from an element or compound. In wastewater treatment, organic matter is oxidized to more stable substances. The opposite of REDUCTION.

**OXIDATION****OXIDATION-REDUCTION POTENTIAL**

The electrical potential required to transfer electrons from one compound or element (the oxidant) to another compound or element (the reductant) and used as a qualitative measure of the state of oxidation in wastewater treatment systems.

**OXIDATION-REDUCTION POTENTIAL****OXIDIZED ORGANICS**

Organic materials that have been broken down in a biological process. Examples of these materials are carbohydrates and proteins that are broken down to simple sugars.

**OXIDIZED ORGANICS****OXIDIZING AGENT**

An oxidizing agent is any substance, such as oxygen (O<sub>2</sub>) and chlorine (Cl<sub>2</sub>), that can add (take on) electrons. When oxygen or chlorine is added to wastewater, organic substances are oxidized. These oxidized organic substances are more stable and less likely to give off odors or to contain disease bacteria. The opposite of REDUCING AGENT.

**OXIDIZING AGENT****OZONIZATION (O-zoe-nie-ZAY-shun)**

The application of ozone to water, wastewater, or air, generally for the purposes of disinfection or odor control.

**OZONIZATION****PACKAGE TREATMENT PLANT**

A small wastewater treatment plant often fabricated at the manufacturer's factory, hauled to the site, and installed as one facility. The package may be either a small primary or a secondary wastewater treatment plant.

**PACKAGE TREATMENT PLANT****PARALLEL OPERATION**

When wastewater being treated is split and a portion flows to one treatment unit while the remainder flows to another similar treatment unit. Also see SERIES OPERATION.

**PARALLEL OPERATION****PARASITIC BACTERIA (PAIR-a-SIT-tick)**

Parasitic bacteria are those bacteria which normally live off another living organism, known as the "host."

**PARASITIC BACTERIA**



**PATHOGENIC ORGANISMS (path-o-JEN-nick)**

Bacteria, viruses or cysts which can cause disease (typhoid, cholera, dysentery). There are many types of bacteria which do *NOT* cause disease and which are *NOT* called pathogenic. Many beneficial bacteria are found in wastewater treatment processes actively cleaning up organic wastes.

**PATHOGENIC ORGANISMS****PERCENT SATURATION**

The amount of a substance that is dissolved in a solution compared with the amount that could be dissolved in the solution, expressed as a percent.

**PERCENT SATURATION**

$$\text{Percent Saturation, \%} = \frac{\text{Amount of Sub. that is Dissolved} \times 100\%}{\text{Amount that Could be Dissolved in Solution}}$$

**PERCOLATION (PURR-ko-LAY-shun)**

The movement or flow of water through soil or rocks.

**PERCOLATION****PERISTALTIC PUMP (peri-STALL-tick)**

A type of positive displacement pump.

**PERISTALTIC PUMP****pH (PEA-A-ch)**

pH is an expression of the intensity of the alkaline or acid condition of a liquid. Mathematically, pH is the logarithm (base 10) of the reciprocal of the hydrogen ion concentration.

**pH**

$$\text{pH} = \text{Log} \frac{1}{(\text{H}^+)}$$

The pH may range from 0 to 14, where 0 is most acid, 14 most alkaline, and 7 is neutral. Natural waters usually have a pH between 8.5 and 8.5.

**PHENOL (FEE-noll)**

An organic compound that is a derivative of benzene.

**PHENOL****PHENOLPHTHALEIN ALKALINITY**

A measure of the hydroxide ions plus one half of the normal carbonate ions in aqueous suspension. Measured by the amount of sulfuric acid required to bring the water to a pH value of 8.3, as indicated by a change in color of phenolphthalein. It is expressed in milligrams per liter of calcium carbonate.

**PHENOLPHTHALEIN ALKALINITY****PHOTOSYNTHESIS (foto-SIN-the-sis)**

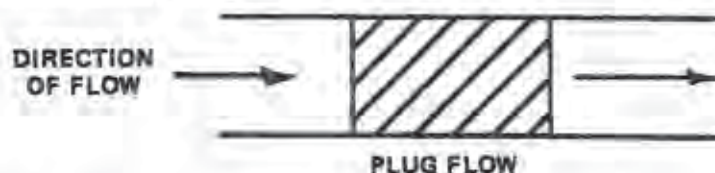
A process in which organisms with the aid of chlorophyll (green plant enzyme) convert carbon dioxide and inorganic substances to oxygen and additional plant material, utilizing sunlight for energy. All green plants grow by this process.

**PHOTOSYNTHESIS****PHYSICAL WASTE TREATMENT PROCESS**

Physical waste treatment processes include use of racks, screens, comminutors, and clarifiers (sedimentation and flotation). Chemical or biological reactions are not an important part of a physical treatment process.

**PHYSICAL WASTE TREATMENT PROCESS****PLUG FLOW**

A type of flow that occurs in tanks, basins or reactors when a slug of wastewater moves through a tank without ever dispersing or mixing with the rest of the wastewater flowing through the tank.

**PLUG FLOW****POLLUTION**

Any change in the natural state of water which interferes with its beneficial reuse or causes failure to meet water-quality requirements.

**POLLUTION****POLYELECTROLYTE (POLY-electro-light)**

A high-molecular-weight substance that is formed by either a natural or synthetic process. Natural polyelectrolytes may be of biological origin or derived from starch products, cellulose derivatives, and alginates. Synthetic polyelectrolytes consist of simple substances that have been made into complex, high-molecular-weight substances. Often called a "polymer."

**POLYELECTROLYTE**



**POLYMER (POLY-mer)****POLYMER**

A high-molecular-weight substance that is formed by either a natural or synthetic process. Natural polymers may be of biological origin or derived from starch products, cellulose derivatives, and alginates. Synthetic polymers consist of simple substances that have been made into complex, high-molecular-weight substances. Often called a "polyelectrolyte."

**POLYSACCHARIDE (poly-SAC-a-ride)****POLYSACCHARIDE**

A carbohydrate such as starch, insulin or cellulose.

**PONDING****PONDING**

A condition occurring on trickling filters when the hollow spaces (voids) become plugged to the extent that water passage through the filter is inadequate. Ponding may be the result of excessive slime growths, trash, or media breakdown.

**POPULATION EQUIVALENT****POPULATION EQUIVALENT**

A means of expressing the strength of organic material in wastewater. In a domestic wastewater system, microorganisms use up about 0.2 pounds of oxygen per day for each person using the system (as measured by the standard BOD test).

$$\text{Pop. Equiv.,} = \frac{\text{Flow, MGD} \times \text{BOD, mg/L} \times 8.34 \text{ lbs/gal}}{\text{persons} \quad 0.2 \text{ lbs BOD/day/person}}$$

**POSTCHLORINATION****POSTCHLORINATION**

The addition of chlorine to the plant discharge or effluent, *FOLLOWING* plant treatment, for disinfection purposes.

**POTABLE WATER (POE-ta-bl)****POTABLE WATER**

Water that does not contain objectionable pollution, contamination, minerals, or infective agents and is considered safe for domestic consumption.

**PRE-AERATION****PRE-AERATION**

The addition of air at the initial stages of treatment to freshen the wastewater, remove gases, add oxygen, promote flotation of grease, and aid coagulation.

**PRECHLORINATION****PRECHLORINATION**

The addition of chlorine at the headworks of the plant *PRIOR TO* other treatment processes mainly for odor and corrosion control. Also applied to aid disinfection, to reduce plant BOD load, to aid in settling, to control foaming in Imhoff units and to help remove oil.

**PRECIPITATE (pre-SIP-i-TATE)****PRECIPITATE**

To separate (a substance) out in solid form from a solution, as by the use of a reagent. The substance precipitated.

**PRECOAT****PRECOAT**

Application of a free-draining, non-cohesive material such as diatomaceous earth to a filtering media. Precoating reduces the frequency of media washing and facilitates cake discharge.

**PRETREATMENT****PRETREATMENT**

The removal of metal, rocks, rags, sand, eggshells, and similar materials which may hinder the operation of a treatment plant. Pretreatment is accomplished by using equipment such as racks, bar screens, comminutors, and grit removal systems.

**PRIMARY TREATMENT****PRIMARY TREATMENT**

A wastewater treatment process that takes place in a rectangular or circular tank and allows those substances in wastewater that readily settle or float to be separated from the water being treated.

**PROCESS VARIABLE****PROCESS VARIABLE**

A physical or chemical quantity which is usually measured and controlled.

**PROTEINACEOUS (PRO-ten-NAY-shus)****PROTEINACEOUS**

Materials containing proteins which are organic compounds containing nitrogen.

**PROTOZOA (pro-toe-ZOE-ah)****PROTOZOA**

A group of microscopic animals (usually single-celled) that sometimes cluster into colonies.

**PRUSSIAN BLUE****PRUSSIAN BLUE**

A paste or liquid used to show a contact area. Used to determine if gate valve seats fit properly.

**PSYCHROPHILIC BACTERIA (sy-kro-FILL-lick)****PSYCHROPHILIC BACTERIA**

Cold temperature bacteria. A group of bacteria that grow and thrive in temperatures below 68°F (20°C).



<b>PURGE</b>	<b>PURGE</b>
To remove a gas or vapor from a vessel, reactor or confined space.	
<b>PUTREFACTION (PEW-tree-FACK-shun)</b>	<b>PUTREFACTION</b>
Biological decomposition of organic matter with the production of ill-smelling products associated with anaerobic conditions.	
<b>PUTRESCIBLE (pew-TRES-uh-bull)</b>	<b>PUTRESCIBLE</b>
Material that will decompose under anaerobic conditions and produce nuisance odors.	
<b>PYROMETER (pie-ROM-uh-ter)</b>	<b>PYROMETER</b>
An apparatus used to measure high temperatures.	
<b>RACK</b>	<b>RACK</b>
Evenly spaced parallel metal bars or rods located in the influent channel to remove rags, rocks, and cans from wastewater.	
<b>RAW WASTEWATER</b>	<b>RAW WASTEWATER</b>
Plant influent or wastewater before any treatment.	
<b>REAGENT (re-A-gent)</b>	<b>REAGENT</b>
A substance which takes part in a chemical reaction and is used to measure, detect, or examine other substances.	
<b>RECALCINE (re-CAL-seen)</b>	<b>RECALCINE</b>
A lime-recovery process in which the calcium carbonate in sludge is converted to lime by heating at 1800°F (980°C).	
<b>RECARBONATION (re-CAR-bun-NAY-shun)</b>	<b>RECARBONATION</b>
A process in which carbon dioxide is bubbled through the water being treated to lower the pH.	
<b>RECEIVING WATER</b>	<b>RECEIVING WATER</b>
A stream, river, lake or ocean into which treated or untreated wastewater is discharged.	
<b>RECHARGE RATE</b>	<b>RECHARGE RATE</b>
Rate at which water is added beneath the ground surface to replenish or recharge groundwater.	
<b>RECIRCULATION</b>	<b>RECIRCULATION</b>
The return of part of the effluent from a treatment process to the incoming flow.	
<b>REDUCING AGENT</b>	<b>REDUCING AGENT</b>
A reducing agent is any substance, such as the chloride ion (Cl <sup>-</sup> ) and sulfide ion (S <sup>-2</sup> ), that can give up electrons. The opposite of OXIDIZING AGENT.	
<b>REDUCTION (re-DUCK-shun)</b>	<b>REDUCTION</b>
Reduction is the addition of hydrogen, removal of oxygen, or the addition of electrons to an element or compound. Under anaerobic conditions in wastewater, sulfate compounds or elemental sulfur are reduced to odor-producing hydrogen sulfide (H <sub>2</sub> S) or the sulfide ion (S <sup>-2</sup> ). The opposite of OXIDATION.	
<b>RELIQUEFACTION (re-LICK-we-FACK-shun)</b>	<b>RELIQUEFACTION</b>
The return of a gas to a liquid. For example, a condensation of chlorine gas returning to the liquid form.	
<b>REFRACTORY MATERIALS (re-FRACK-tory)</b>	<b>REFRACTORY MATERIALS</b>
Material difficult to remove entirely from wastewater such as nutrients, color, taste- and odor-producing substances and some toxic materials.	
<b>REPRESENTATIVE SAMPLE</b>	<b>REPRESENTATIVE SAMPLE</b>
A portion of material or water identical in content to that in the larger body of material or water being sampled.	
<b>RESIDUAL CHLORINE</b>	<b>RESIDUAL CHLORINE</b>
Residual chlorine is the amount of chlorine remaining after a given contact time and under specific conditions.	
<b>RESPIRATION</b>	<b>RESPIRATION</b>
The process in which an organism uses oxygen for its life processes and gives off carbon dioxide.	



**RETENTION TIME**

The time water, sludge or solids are retained or held in a clarifier or sedimentation tank. See DETENTION TIME.

**RETENTION TIME****RIPRAP**

Broken stones, boulders, or other materials placed compactly or irregularly on levees or dikes for the protection of earth surfaces against the erosive action of waves.

**RIPRAP****RISING SLUDGE**

Rising sludge occurs in the secondary clarifiers of activated sludge plants when the sludge settles to the bottom of the clarifier, is compacted, and then starts to rise to the surface, usually as a result of denitrification.

**RISING SLUDGE****ROTAMETER**

A device used to measure the flow rate of gases and liquids. The gas or liquid being measured flows vertically up a calibrated tube. Inside the tube is a small ball or a bullet-shaped float (it may rotate) that rises or falls depending on the flow rate. The flow rate may be read on a scale behind the middle of the ball or the top of the float.

**ROTAMETER****ROTARY PUMP**

A type of displacement pump consisting essentially of elements rotating in a pump case which they closely fit. The rotation of these elements alternately draws in and discharges the water being pumped. Such pumps act with neither suction nor discharge valves, operate at almost any speed, and do not depend on centrifugal forces to lift the water.

**ROTARY PUMP****ROTIFERS (ROE-ti-fers)**

Microscopic animals characterized by short hairs on their front end.

**ROTIFERS****SAR (Sodium Adsorption Ratio)**

This ratio expresses the relative activity of sodium ions in the exchange reactions with soil. The ratio is defined as follows:

**SAR**

$$SAR = \frac{Na}{\left[ \frac{1}{2} (Ca + Mg) \right]^{1/2}}$$

where Na, Ca, and Mg are concentrations of the respective ions in milliequivalents per liter of water.

$$Na, \text{ meq/L} = \frac{Na, \text{ mg/L}}{23.0 \text{ mg/meq}} \quad Ca, \text{ meq/L} = \frac{Ca, \text{ mg/L}}{20.0 \text{ mg/meq}}$$

$$Mg, \text{ meq/L} = \frac{Mg, \text{ mg/L}}{12.15 \text{ mg/meq}}$$

**SCFM**

Cubic Feet of air per Minute at Standard conditions of temperature and pressure.

**SCFM****SVI (Sludge Volume Index)**

This is a test used to indicate the settling ability of activated sludge (aerated solids) in the secondary clarifier. The test is a measure of the volume of sludge compared with its weight. Allow the sludge sample from the aeration tank to settle for 30 minutes. Then calculate SVI by dividing the volume (ml) of wet settled sludge by the weight (mg) of that sludge after it has been dried. Sludge with an SVI of one hundred or greater will not settle as readily as desirable because it is as light as or lighter than water.

**SVI**

$$SVI = \frac{\text{Wet Settled Sludge, ml} \times 1000}{\text{Dried Sludge Solids, mg}}$$

**SANITARY SEWER (SAN-eh-tare-ee SUE-er)**

A sewer intended to carry wastewater from homes, businesses, and industries. Storm water runoff should be collected and transported in a separate system of pipes.

**SANITARY SEWER****SAPROPHYTIC ORGANISMS (SAP-pro-FIT-ik)**

Organisms living on dead or decaying organic matter. They help natural decomposition of the organic solids in wastewater.

**SAPROPHYTIC ORGANISMS****SCREEN**

A device used to retain or remove suspended or floating objects in wastewater. The screen has openings that are generally uniform in size. It retains or removes objects larger than the openings. A screen may consist of bars, rods, wires, gratings, wire mesh, or perforated plates.

**SCREEN****SEALING WATER**

Water used to prevent wastewater or dirt from reaching moving parts. Sealing water is at a higher pressure than the wastewater it is keeping out of a mechanical device.

**SEALING WATER**



**SECCHI DISC (SECK-key)**

A flat, white disc lowered into the water by a rope until it is just barely visible. At this point, the depth of the disc from the water surface is the recorded secchi disc reading.

**SECCHI DISC****SECONDARY TREATMENT**

A wastewater treatment process used to convert dissolved or suspended materials into a form more readily separated from the water being treated. Usually the process follows primary treatment by sedimentation. The process commonly is a type of biological treatment process followed by secondary clarifiers that allow the solids to settle out from the water being treated.

**SECONDARY TREATMENT****SEED SLUDGE**

In wastewater treatment, seed, seed culture or seed sludge refers to a mass of sludge which contains very concentrated populations of microorganisms. When a seed sludge is mixed with the wastewater or sludge being treated, the process of biological decomposition takes place more rapidly.

**SEED SLUDGE****SEIZING**

Seizing occurs when an engine overheats and a component expands so the engine will not run. Also called "freezing."

**SEIZING****SEPTIC (SEP-tick)**

This condition is produced by anaerobic bacteria. If severe, the wastewater turns black, gives off foul odors, contains little or no dissolved oxygen and creates a heavy oxygen demand.

**SEPTIC****SEPTICITY (sep-TIS-it-tee)**

Septicity is the condition in which organic matter decomposes to form foul-smelling products associated with the absence of free oxygen. If severe, the wastewater turns black, gives off foul odors, contains little or no dissolved oxygen and creates a heavy oxygen demand.

**SEPTICITY****SERIES OPERATION**

When wastewater being treated flows through one treatment unit and then flows through another similar treatment unit. Also see PARALLEL OPERATION.

**SERIES OPERATION****SET POINT**

The position at which the control or controller is set. This is the same as the desired value of the process variable.

**SET POINT****SEWAGE**

The used water and solids from homes that flow to a treatment plant. The preferred term is wastewater.

**SEWAGE****SHEAR PIN**

A straight pin with a groove around the middle that will weaken the pin and cause it to fail when a certain load or stress is exceeded. The purpose of the pin is to protect equipment from damage due to excessive loads or stresses.

**SHEAR PIN****SHOCK LOAD**

The arrival at a plant of a waste which is toxic to organisms in sufficient quantity or strength to cause operating problems. Possible problems include odors and sloughing off of the growth or slime on the trickling-filter media. Organic or hydraulic overloads also can cause a shock load.

**SHOCK LOAD****SHORT-CIRCUITING**

A condition that occurs in tanks or ponds when some of the water or wastewater travels faster than the rest of the flowing water.

**SHORT-CIRCUITING****SHREDDING**

Comminution. A mechanical treatment process which cuts large pieces of wastes into smaller pieces so they won't plug pipes or damage equipment. *SHREDDING* and *COMMUNITION* usually mean the same thing.

**SHREDDING****SIDESTREAM**

Wastewater flows that develop from other storage or treatment facilities. This wastewater may or may not need additional treatment.

**SIDESTREAM****SIGNIFICANT FIGURE**

The number of accurate numbers in a measurement. If the distance between two points is measured to the nearest hundredth and recorded as 238.41 feet, the measurement has five significant figures.

**SIGNIFICANT FIGURE****SINGLE-STAGE PUMP**

A pump that has only one impeller. A multi-stage pump has more than one impeller.

**SINGLE-STAGE PUMP**



**SKATOLE (SKATE-tole)****SKATOLE**

An organic compound (C<sub>8</sub>H<sub>9</sub>N) containing nitrogen which has a fecal odor.

**SLAKE****SLAKE**

To become mixed with water so that a true chemical reaction takes place, such as in the slaking of lime.

**SLOUGHINGS (SLUFF-ings)****SLOUGHINGS**

Trickling-filter slimes that have been washed off the filter media. They are generally quite high in BOD and will lower effluent quality unless removed.

**SLUDGE (sluj)****SLUDGE**

The settleable solids separated from liquids during processing or the deposits of foreign materials on the bottoms of streams or other bodies of water.

**SLUDGE AGE****SLUDGE AGE**

A measure of the length of time a particle of suspended solids has been undergoing aeration in the activated sludge process.

$$\text{Sludge Age, days} = \frac{\text{Suspended Solids Under Aeration, lbs or kg}}{\text{Suspended Solids Added, lbs/day or kg/day}}$$

**SLUDGE DENSITY INDEX (SDI)****SLUDGE DENSITY INDEX (SDI)**

This test is used in a way similar to the Sludge Volume Index (SVI) to indicate the settleability of a sludge in a secondary clarifier or effluent. SDI = 100/SVI. Also see SLUDGE VOLUME INDEX (SVI).

**SLUDGE DIGESTION****SLUDGE DIGESTION**

The process of changing organic matter in sludge into a gas or a liquid or a more stable solid form. These changes take place as microorganisms feed on sludge in anaerobic (more common) or aerobic digesters.

**SLUDGE GASIFICATION****SLUDGE GASIFICATION**

A process in which soluble and suspended organic matter are converted into gas by anaerobic decomposition. The resulting gas bubbles can become attached to the settled sludge and cause large clumps of sludge to rise and float on the water surface.

**SLUDGE VOLUME INDEX (SVI)****SLUDGE VOLUME INDEX (SVI)**

This is a test used to indicate the settling ability of activated sludge (aerated solids) in the secondary clarifier. The test is a measure of the volume of sludge compared with its weight. Allow the sludge sample from the aeration tank to settle for 30 minutes. Then calculate SVI by dividing the volume (ml) of wet settled sludge by the weight (mg) of that sludge after it has been dried. Sludge with an SVI of one hundred or greater will not settle as readily as desirable because it is as light as or lighter than water.

$$\text{SVI} = \frac{\text{Wet Settled Sludge, ml} \times 1000}{\text{Dried Sludge Solids, mg}}$$

**SLUDGE-VOLUME RATIO (SVR)****SLUDGE-VOLUME RATIO (SVR)**

The volume of sludge blanket divided by the daily volume of sludge pumped from the thickener.

**SLUGS****SLUGS**

Intermittent releases or discharges of industrial wastes.

**SLURRY (SLUR-e)****SLURRY**

A thin watery mud or any substance resembling it (such as a grit slurry or a lime slurry).

**SODIUM ADSORPTION RATIO (SAR)****SODIUM ADSORPTION RATIO (SAR)**

This ratio expresses the relative activity of sodium ions in the exchange reactions with soil. The ratio is defined as follows:

$$\text{SAR} = \frac{\text{Na}}{[\frac{1}{2}(\text{Ca} + \text{Mg})]^{1/2}}$$

where Na, Ca, and Mg are concentrations of the respective ions in milliequivalents per liter of water.

$$\text{Na, meq/L} = \frac{\text{Na, mg/L}}{23.0 \text{ mg/meq}}$$

$$\text{Ca, meq/L} = \frac{\text{Ca, mg/L}}{20.0 \text{ mg/meq}}$$

$$\text{Mg, meq/L} = \frac{\text{Mg, mg/L}}{12.15 \text{ mg/meq}}$$

**SOLUBLE BOD****SOLUBLE BOD**

Soluble BOD is the BOD of water that has been filtered in the standard suspended solids test.



<b>SOLUTE</b>	<b>SOLUTE</b>
The substance dissolved in a solution. A solution is made up of the solvent and the solute.	
<b>SOLUTION</b>	<b>SOLUTION</b>
A liquid mixture of dissolved substances. In a solution it is impossible to see all the separate parts.	
<b>SPECIFIC GRAVITY</b>	<b>SPECIFIC GRAVITY</b>
Weight of a particle or substance in relation to the weight of water. Water has a specific gravity of 1.000 at 4°C (or 39°F). Wastewater particles usually have a specific gravity of 0.5 to 2.5.	
<b>SPLASH PAD</b>	<b>SPLASH PAD</b>
A structure made of concrete or other durable material to protect bare soil from erosion by splashing or falling water.	
<b>STABILIZE</b>	<b>STABILIZE</b>
To convert to a form that resists change. Organic material is stabilized by bacteria which convert the material to gases and other relatively inert substances. Stabilized organic material generally will not give off obnoxious odors.	
<b>STABILIZED WASTE</b>	<b>STABILIZED WASTE</b>
A waste that has been treated or decomposed to the extent that, if discharged or released, its rate and state of decomposition would be such that the waste would not cause a nuisance or odors.	
<b>STANDARD SOLUTION</b>	<b>STANDARD SOLUTION</b>
A solution in which the exact concentration of a chemical or compound is known.	
<b>STANDARDIZE</b>	<b>STANDARDIZE</b>
(1) To compare with a standard. In wet chemistry, to find out the exact strength of a solution by comparing with a standard of known strength. This information is used to adjust the strength by adding more water or more of the substance dissolved. (2) To compare an instrument or device with a standard. This helps you to adjust the instrument so that it reads accurately or to prepare a scale, graph or chart that is accurate.	
<b>STASIS (STAY-sis)</b>	<b>STASIS</b>
Stagnation or inactivity of the life processes within organisms.	
<b>STATIC HEAD</b>	<b>STATIC HEAD</b>
When water is not moving, the distance (in feet or meters) from a point to the water surface.	
<b>STATOR</b>	<b>STATOR</b>
That portion of a machine which contains the stationary (non-moving) parts that surround the moving parts.	
<b>STEP-FEED AERATION</b>	<b>STEP-FEED AERATION</b>
Step-feed aeration is a modification of the conventional activated sludge process. In step aeration, primary effluent enters the aeration tank at several points along the length of the tank, rather than all of the primary effluent entering at the beginning or head of the tank and flowing through the entire tank.	
<b>STERILIZATION (star-uh-luh-ZAY-shun)</b>	<b>STERILIZATION</b>
The removal or destruction of all living microorganisms, including pathogenic and saprophytic bacteria, vegetative forms and spores. Compare with DISINFECTION.	
<b>STETHOSCOPE</b>	<b>STETHOSCOPE</b>
An instrument used to magnify sounds and convey them to the ear.	
<b>STOP LOG</b>	<b>STOP LOG</b>
A log or board in an outlet box or device used to control the water level in ponds.	
<b>STORM SEWER</b>	<b>STORM SEWER</b>
A separate sewer that carries runoff from storms, surface drainage, and street wash, but does not include domestic and industrial wastes.	
<b>STRIPPED GASES</b>	<b>STRIPPED GASES</b>
Gases that are released from a liquid by bubbling air through the liquid or by allowing the liquid to be sprayed or tumbled over media.	



**STRIPPED ODORS**

Odors that are released from a liquid by bubbling air through the liquid or by allowing the liquid to be sprayed and/or tumbled over media.

**STRIPPED ODORS****STUCK**

Not working. A stuck digester does not decompose organic matter properly. The digester is characterized by low gas production, high volatile acid to alkalinity relationship, and poor liquid-solids separation. A digester in a stuck condition is sometimes called a "sour" or "upset" digester.

**STUCK****SUCTION HEAD**

The pressure (in feet (meters) or pounds per square inch (kilograms per square centimeter)) on the suction side of a pump. The pressure can be measured from the center line of the pump *UP TO* the elevation of the hydraulic grade line on the suction side of the pump.

**SUCTION HEAD****SUCTION LIFT**

The *NEGATIVE* pressure (in feet (meters) or inches (centimeters) of mercury vacuum) on the suction side of the pump. The pressure can be measured from the center line of the pump *DOWN TO* the elevation of the hydraulic grade line on the suction side of the pump.

**SUCTION LIFT****SUPERNATANT** (sue-per-NAY-ternt)

Liquid removed from settled sludge. Supernatant commonly refers to the liquid between the sludge on the bottom and the scum on the surface of an anaerobic digester. This liquid is usually returned to the influent wet well or to the primary clarifier.

**SUPERNATANT****SURFACE LOADING**

Surface loading is calculated by dividing the flow into a sedimentation tank or a clarifier by the surface area of the unit.

**SURFACE LOADING**

$$\text{Surface Loading, gpd/sq ft} = \frac{\text{Flow, gpd}}{\text{Surface Area, sq ft}}$$

**SURFACTANT**

Abbreviation for surface-active agent. The active agent in detergents that possesses a high cleaning ability.

**SURFACTANT****SUSPENDED SOLIDS**

(1) Solids that either float on the surface of, or are in suspension in, water, wastewater, or other liquids, and which are largely removable by laboratory filtering. (2) The quantity of material removed from wastewater in a laboratory test, as prescribed in *STANDARD METHODS FOR THE EXAMINATION OF WATER AND WASTEWATER* and referred to as nonfilterable residue.

**SUSPENDED SOLIDS****TOC**

Total Organic Carbon. TOC measures the amount of organic carbon in water.

**TOC****TERTIARY TREATMENT** (TER-she-AIR-ee)

Any process of water renovation that upgrades treated wastewater to meet specific reuse requirements. May include general cleanup of water or removal of specific parts of wastes insufficiently removed by conventional treatment processes. Typical processes include chemical treatment and pressure filtration. Also called **ADVANCED WASTE TREATMENT**.

**TERTIARY TREATMENT****THERMOPHILIC BACTERIA** (thermo-FILL-lick)

Hot temperature bacteria. A group of bacteria that grow and thrive in temperatures above 113°F (45°C). The optimum temperature range for these bacteria in anaerobic decomposition is 120°F (49°C) to 135°F (57°C).

**THERMOPHILIC BACTERIA****THIEF HOLE**

A digester sampling well.

**THIEF HOLE****THRESHOLD ODOR**

The minimum odor of a sample (gas or water) that can just be detected after successive odorless (gas or water) dilutions.

**THRESHOLD ODOR****TIME LAG**

The time required for processes and control systems to respond to a signal or to reach a desired level.

**TIME LAG****TITRATE** (TIE-trate)

To *TITRATE* a sample, a chemical solution of known strength is added on a drop-by-drop basis until a color change, precipitate, or pH change in the sample is observed (end point). Titration is the process of adding the chemical solution to completion of the reaction as signaled by the end point.

**TITRATE**



<b>TOTAL DYNAMIC HEAD (TDH)</b>	<b>TOTAL DYNAMIC HEAD (TDH)</b>
When a pump is lifting or pumping water, the vertical distance (in feet or meters) from the elevation of the energy grade line on the suction side of the pump to the elevation of the energy grade line on the discharge side of the pump.	
<b>TOTAL RESIDUAL CHLORINE</b>	<b>TOTAL RESIDUAL CHLORINE</b>
The amount of chlorine remaining after a given contact time. The sum of the combined available residual chlorine and the free available residual chlorine. Also see RESIDUAL CHLORINE.	
<b>TOTALIZER</b>	<b>TOTALIZER</b>
A device that continuously sums or adds the flow into a plant in gallons or million gallons or some other unit of measurement.	
<b>TOXIC (TOX-ick)</b>	<b>TOXIC</b>
Poisonous.	
<b>TOXICITY (tox-IS-it-tes)</b>	<b>TOXICITY</b>
A condition which may exist in wastes and will inhibit or destroy the growth or function of certain organisms.	
<b>TRANSPIRATION (TRAN-speer-RAY-shun)</b>	<b>TRANSPIRATION</b>
The process by which water vapor is lost to the atmosphere from living plants.	
<b>TRICKLING FILTER</b>	<b>TRICKLING FILTER</b>
A treatment process in which the wastewater trickles over media that provide the opportunity for the formation of slimes or biomass which contain organisms that feed upon and remove wastes from the water treated.	
<b>TRICKLING-FILTER MEDIA</b>	<b>TRICKLING-FILTER MEDIA</b>
Rocks or other durable materials that make up the body of the filter. Synthetic (manufactured) media have been used successfully.	
<b>TRUNK SEWER</b>	<b>TRUNK SEWER</b>
A sewer that receives wastewater from many tributary branches or sewers and serves a large territory and contributing population.	
<b>TURBID</b>	<b>TURBID</b>
Having a cloudy or muddy appearance.	
<b>TURBIDITY METER</b>	<b>TURBIDITY METER</b>
An instrument for measuring the amount of particles suspended in water. Precise measurements are made by measuring how light is scattered by the suspended particles. The normal measuring range is 0 to 100 and is expressed as Nephelometric Turbidity Units (NTU's).	
<b>TURBIDITY UNITS</b>	<b>TURBIDITY UNITS</b>
Turbidity units, if measured by nephelometric (reflected light) instrumental procedure, are expressed in nephelometric turbidity units (NTU). Those turbidity units obtained by other instrumental methods or visual methods are expressed in Jackson Turbidity Units (JTU) and sometimes as Formazin Turbidity Units (FTU). The FTU nomenclature comes from the Formazin polymer used to prepare the turbidity standards for instrument calibration. Turbidity units are a measure of the cloudiness of water.	
<b>TWO-STAGE FILTERS</b>	<b>TWO-STAGE FILTERS</b>
Two filters are used. Effluent from the first filter goes to the second filter, either directly or after passing through a clarifier.	
<b>ULTRAFILTRATION</b>	<b>ULTRAFILTRATION</b>
A membrane filtration process used for the removal of organic compounds in an aqueous (watery) solution.	
<b>UPSET</b>	<b>UPSET</b>
An upset digester does not decompose organic matter properly. The digester is characterized by low gas production, high volatile acid/alkalinity relationship, and poor liquid-solids separation. A digester in an upset condition is sometimes called a "sour" or "stuck" digester.	
<b>VELOCITY HEAD</b>	<b>VELOCITY HEAD</b>
A vertical height (in feet or meters) equal to the square of the velocity of flowing water divided by twice the acceleration due to gravity ( $V^2/2g$ ).	
<b>VOLATILE (VOL-a-til)</b>	<b>VOLATILE</b>
A volatile substance is one that is capable of being evaporated or changed to a vapor at relatively low temperatures.	



**VOLATILE ACIDS**

Acids produced during digestion. Fatty acids which are soluble in water and can be steam-distilled at atmospheric pressure. Also called "organic acids." Volatile acids are commonly reported as equivalent to acetic acid.

**VOLATILE ACIDS****VOLATILE LIQUIDS**

Liquids which easily vaporize or evaporate at room temperature.

**VOLATILE LIQUIDS****VOLATILE SOLIDS**

Those solids in water, wastewater, or other liquids that are lost on ignition of the dry solids at 550°C.

**VOLATILE SOLIDS****VOLUMETRIC**

A means of measuring unknown concentrations of water quality indicators in a sample *BY DETERMINING THE VOLUME* of titrant or liquid reagent needed to complete particular reactions.

**VOLUMETRIC****VOLUTE (vol-LOOT)**

The spiral-shaped casing which surrounds a pump, blower, or turbine impeller and collects the liquid or gas discharged by the impeller.

**VOLUTE****WASTEWATER**

The used water and solids from a community that flow to a treatment plant. Storm water, surface water, and groundwater infiltration also may be included in the wastewater that enters a plant. The term "sewage" usually refers to household wastes, but this word is being replaced by the term "wastewater."

**WASTEWATER****WATER HAMMER**

The sound like someone hammering on a pipe that occurs when a valve is opened or closed very rapidly. When a valve position is changed quickly, the water pressure in a pipe will increase and decrease back and forth very quickly. This rise and fall in pressures can do serious damage to the system.

**WATER HAMMER****WEIR (weer)**

(1) A wall or plate placed in an open channel and used to measure the flow. The depth of the flow over the weir can be used to calculate the flow rate, or a chart or conversion table may be used. (2) A wall or obstruction used to control flow (from clarifiers) to assure uniform flow and avoid short-circuiting.

**WEIR****WEIR DIAMETER (weir)**

Many circular clarifiers have a circular weir within the outside edge of the clarifier. All the water leaving the clarifier flows over this weir. The diameter of the weir is the length of a line from one edge of a weir to the opposite edge and passing through the center of the circle formed by the weir.

**WEIR DIAMETER****WEIR, PROPORTIONAL (weir)**

A specially shaped weir in which the flow through the weir is directly proportional to the head.

**WEIR, PROPORTIONAL****WET OXIDATION**

A method of treating or conditioning sludge before the water is removed. Compressed air is blown into the liquid sludge. The air and sludge mixture is fed into a pressure vessel where the organic material is stabilized. The stabilized organic material and inert (inorganic) solids are then separated from the pressure vessel effluent by dewatering in lagoons or by mechanical means.

**WET OXIDATION****WET WELL**

A compartment or room in which wastewater is collected. The suction pipe of a pump may be connected to the wet well or a submersible pump may be located in the wet well.

**WET WELL****Y, GROWTH RATE**

An experimentally determined constant to estimate the unit growth rate of bacteria while degrading organic wastes.

**Y, GROWTH RATE****ZOOGLAAL FILM (ZOE-gee-ai)**

A complex population of organisms that form a "slime growth" on the trickling-filter media and break down the organic matter in wastewater. These slimes consist of living organisms feeding on the wastes in wastewater, dead organisms, silt, and other debris. "Slime growth" is a more common word.

**ZOOGLAAL FILM****ZOOGLAAL MASS (ZOE-gee-ai)**

Jelly-like masses of bacteria found in both the trickling filter and activated sludge processes. These masses may be formed for or function as the protection against predators and for storage of food supplies. Also see BIOMASS.

**ZOOGLAAL MASS**